



Initial Phase – Erosion & Sediment  
Control Plan  
Fairfield I-77 Development Site  
Fairfield County, South Carolina  
S&ME Project No. 210730C

PREPARED FOR:

**Luck Stone Corporation**  
515 Stone Mill Drive (PO Box 29682)  
Richmond, VA 23242

PREPARED BY:

**S&ME, Inc.**  
2016 Ayrsley Town Blvd., Suite 2-A  
Charlotte, NC 28273

**March 19, 2021**



## **Appendices**

Appendices

Appendix I – Drawings

Appendix II – Sediment Basin Calculations

## Appendices

## **Appendix I – Drawings**

# FAIRFIELD I-77 DEVELOPMENT SITE, E&SC PLAN - INITIAL PHASE

## LUCK STONE CORPORATION

FAIRFIELD COUNTY, SOUTH CAROLINA

MARCH 22, 2021

### SITE DATA

PARCEL ID(S): 166-00-00-018-000,  
166-00-00-028-000,  
166-00-00-030-000

SITE ADDRESS: SC HIGHWAY 34  
RIDGEWAY, SOUTH CAROLINA

SITE ACREAGE: 416 AC.

EXISTING ZONING: R2

PROPOSED USE: AGGREGATE MINE OPERATIONS

LATITUDE: 34°18'52.92"N (34.3147°)

LONGITUDE: -81°11'0.92"W (-81.0197°)

RIVER BASIN: LAKE WATEREE-CATAWBA RIVER

RECEIVING WATERBODY: DUTCHMANS CREEK

OWNER: LUCK STONE CORPORATION

ADDRESS: 515 STONE MILL DRIVE (PO BOX 29682)  
RICHMOND, VIRGINIA 23242  
(804) 784-6300

PHONE NO.: (804) 784-6300

CONTACT NAME: BRUCE SMITH

CONTACT E-MAIL ADDRESS: brucesmith@luckcompanies.com

PROJECT REPRESENTATIVE: S&ME INC.

ADDRESS: 2016 ARSLEY TOWN BLVD. SUITE 2-A  
CHARLOTTE, NC 28273  
(704)523-4726

PHONE NO.: (704)523-4726

CONTACT NAME: CHRISTOPHER J.L. STAHL

CONTACT E-MAIL ADDRESS: cstahl@smeinc.com

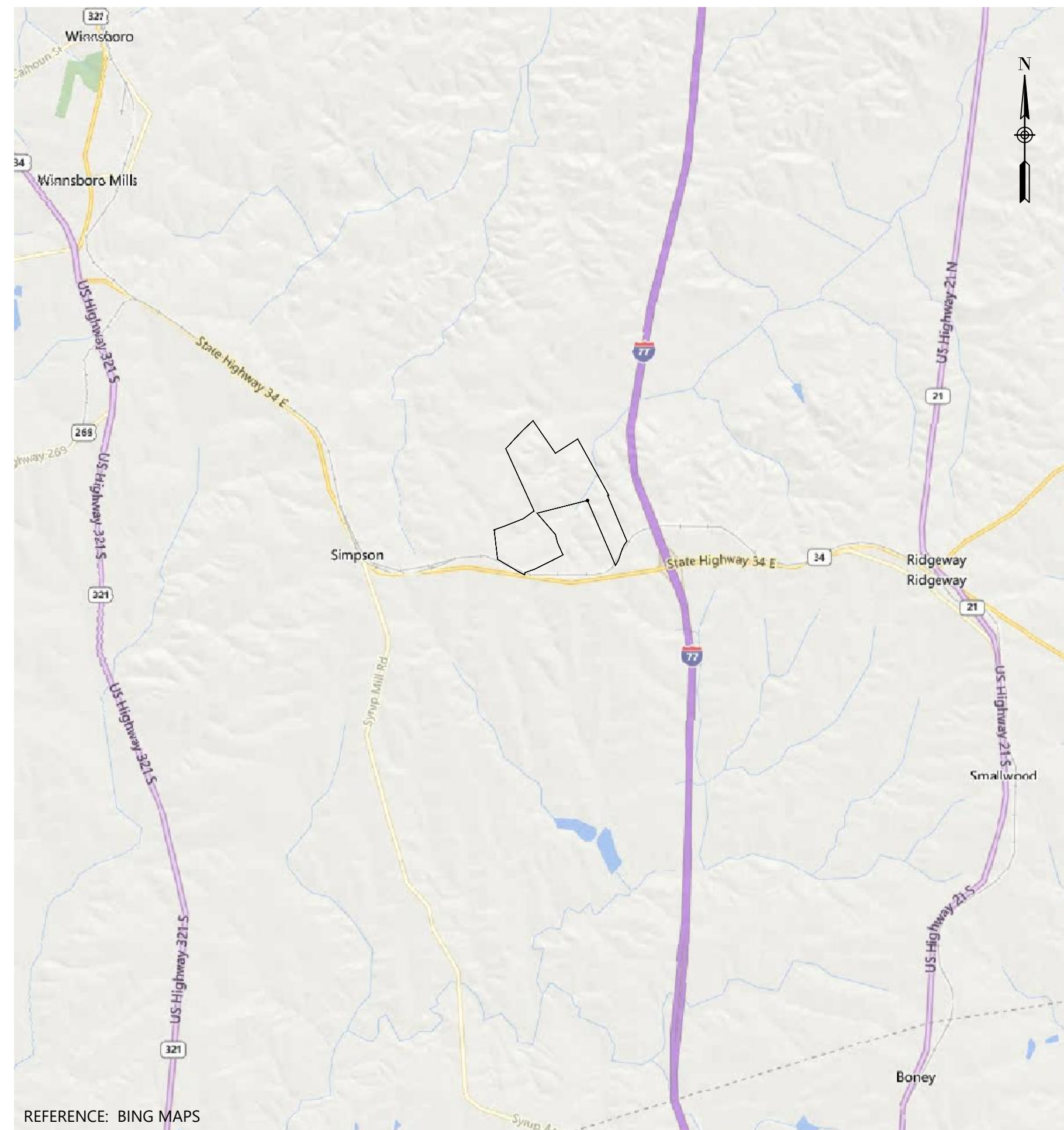

VICINITY MAP  
SCALE: 1" = 5,000'

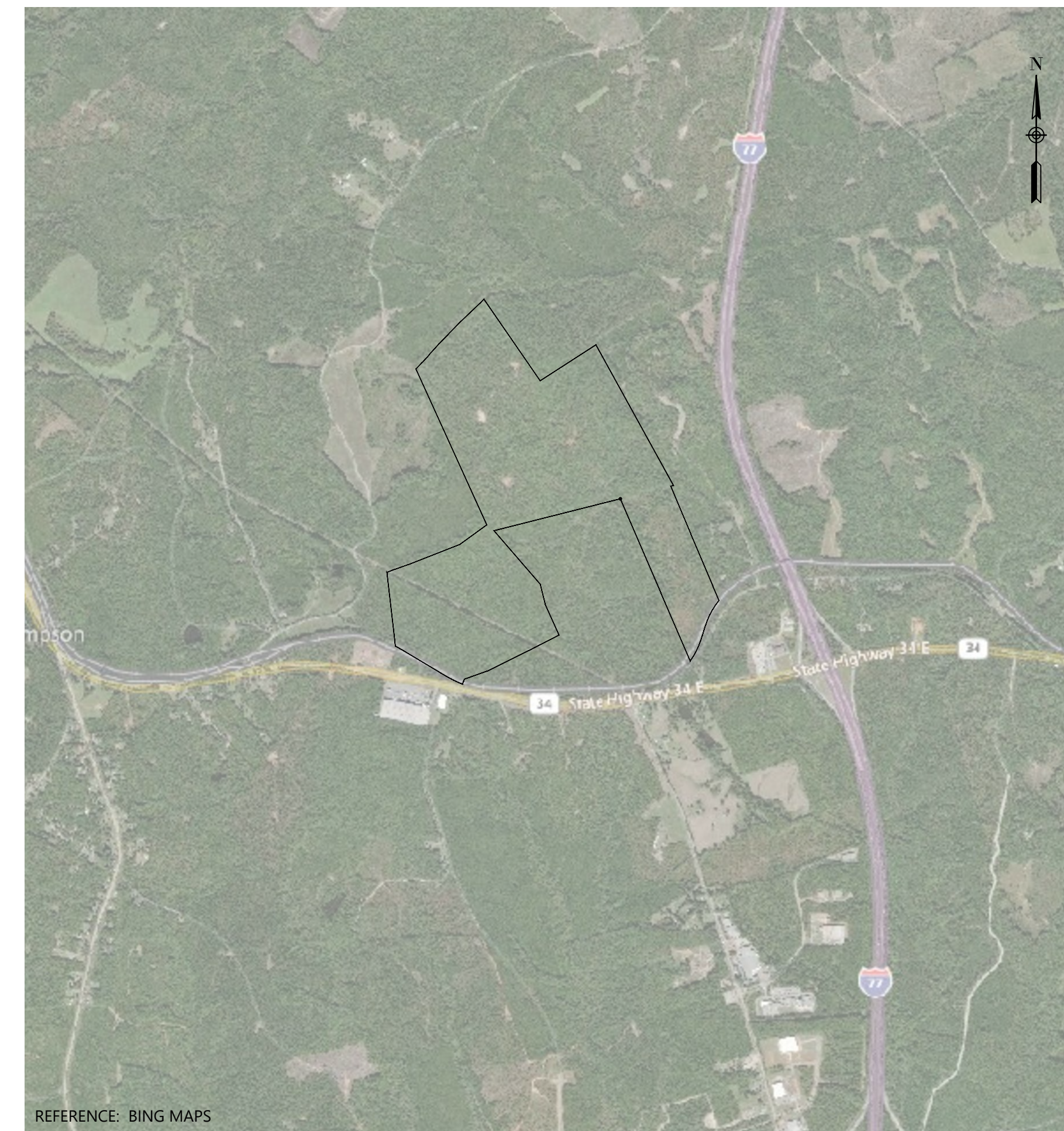

SITE LOCATION  
SCALE: 1" = 2,000'

### DRAWINGS

NUMBER	TITLE
0	COVER SHEET
1	EXISTING CONDITIONS PLAN
2	OVERALL SITE PLAN
3	DETAILS (SHEET 1 OF 4)
4	DETAILS (SHEET 2 OF 4)
5	DETAILS (SHEET 3 OF 4)
6	DETAILS (SHEET 4 OF 4)

PREPARED FOR



515 STONE MILL DRIVE  
RICHMOND, VIRGINIA 23242  
(804) 784-6300

CIVIL ENGINEER



2016 ARSLEY TOWN BLVD.  
SUITE 2-A  
CHARLOTTE, NC 28273  
(704) 523-4726



DRAWING PATH: R:\CADD\at\Cherokee\2017\LUCK STONE ALT. 1-77\DWG\EG&SC\EXISTING SITE CONDITIONS.dwg



**LEGEND**

- EXISTING GRADE CONTOUR (5 FEET)
- EXISTING GRADE CONTOUR (25 FEET)
- - - PROPERTY LINE
- - - PERMIT BOUNDARY
- STREAMS
- /// WETLANDS

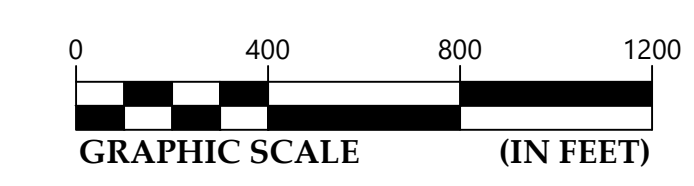

9751 SOUTHERN PINE BLVD  
CHARLOTTE, NC 28273  
(704) 523-4726

ENGINEERING FIRM  
LICENSE NUMBER: F-0176

NO.	DATE	DESCRIPTION	BY	CHK	APV
1	3-22-21	REVISED INITIAL PROCESS PLAN			

**EXISTING CONDITIONS PLAN**

PROJECT NUMBER  
**210730C**  
DRAWING NUMBER

FAIRFIELD 1-77 DEVELOPMENT SITE, E&SC PLAN - INITIAL PHASE  
LUCK STONE CORPORATION  
FAIRFIELD COUNTY, SOUTH CAROLINA



9751 SOUTHERN PINE BLVD  
CHARLOTTE, NC 28273  
(704) 523-4726

ENGINEERING FIRM  
LICENSE NUMBER: F-0176



**LEGEND**

- - - - - EXISTING GRADE CONTOUR (5 FEET)
- - - - - EXISTING GRADE CONTOUR (25 FEET)
- — — — — PROPERTY LINE
- — — — — PERMIT BOUNDARY
- — — — — STREAMS
- ▨▨▨▨▨▨ WETLANDS
- ▨▨▨▨▨▨ 50-FT. BUFFER
- ▨▨▨▨▨▨ BERM/OVERBURDEN STORAGE
- — — — — ACCESS/HAUL ROAD
- - - - - BLASTING LIMIT
- ▨▨▨▨▨▨ PERIMETER CHANNEL
- ▨▨▨▨▨▨ SEDIMENT BASIN

**GENERAL NOTE:**

- SWPPP WILL PROVIDE DETAILED STORMWATER CONTROL DEVICES TO ADDRESS STORMWATER POLLUTANTS DURING CONSTRUCTION AND OPERATIONS.

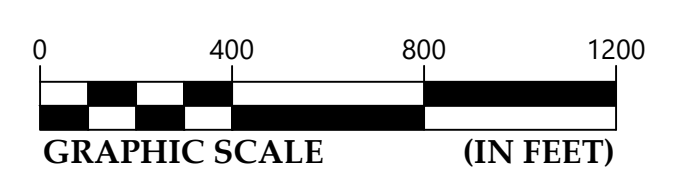

NO.	DATE	BY	CHK	APV	DESCRIPTION
1	3-22-21				REVISED INITIAL PROCESS PLAN

**OVERALL SITE PLAN**

FAIRFIELD-177 DEVELOPMENT SITE, E&SC PLAN - INITIAL PHASE  
LUCK STONE CORPORATION  
FAIRFIELD COUNTY, SOUTH CAROLINA

PROJECT NUMBER  
**210730C**

DRAWING NUMBER  
**2**      **6**

DRAWING PATH: R:\CADD\at\charlotte\2017\LUCK STONE ALT-177\DWG\EG&SC\OVERALL SITE DEVELOPMENT.dwg



9751 SOUTHERN PINE BLVD  
CHARLOTTE, NC 28273  
(704) 523-4726

ENGINEERING FIRM  
LICENSE NUMBER: F-0176

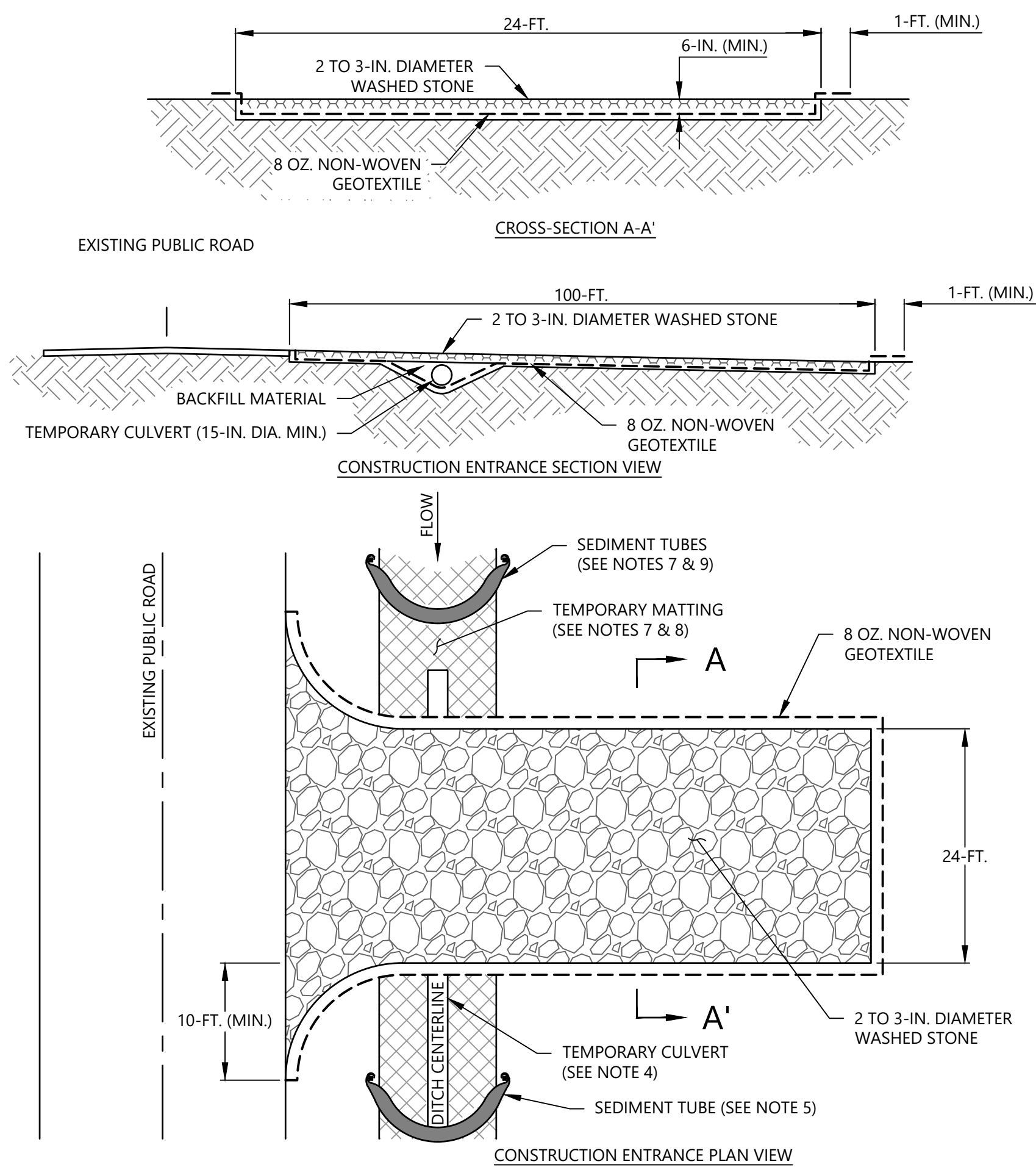

1  
3 CONSTRUCTION ENTRANCE  
SCALE: N.T.S.

- TEMPORARY CONSTRUCTION ENTRANCE NOTES**
- PHASE 1 E&S&C**
1. DUE TO SITE CONSTRAINTS THE WIDTH AND LENGTH MAY BE ADJUSTED BASED ON CONDITIONS IN THE FIELD.
  2. APPROPRIATE SIGNAGE WILL BE POSTED ALONG THE ROAD TO INFORM THE GENERAL PUBLIC OF POTENTIAL CONSTRUCTION TRAFFIC PER REQUIREMENTS.
  3. STOCKPILE TOPSOIL FROM CONSTRUCTION ENTRANCE INSTALLATION. USE TOPSOIL FOR BACKFILL AFTER REMOVAL OF CONSTRUCTION ENTRANCE DURING FINAL CLEANUP.
  4. THE NEAREST UPSTREAM AND DOWNSTREAM CULVERT DIAMETER(S) WILL BE OBSERVED AT EACH LOCATION A CONSTRUCTION ENTRANCE IS TO BE INSTALLED WITHIN A ROADSIDE SWALE/DITCH. DIAMETER OF TEMPORARY CULVERT SHALL BE THE LARGER OF EITHER THE CULVERT, BUT NO LESS THAN 15-IN. IN DIAMETER. CONTRACTOR SHALL FIELD VERIFY AND DETERMINE APPROPRIATE CULVERT TO BE USED.
  5. INSTALL SEDIMENT TUBE IN SWALE/DITCH AT UPSTREAM AND DOWNSTREAM LOCATIONS OF LIMITS OF DISTURBANCE.
- PHASE 2 E&S&C & CONSTRUCTION**
6. MAINTAIN CONSTRUCTION ENTRANCE IN ACCORDANCE WITH MAINTENANCE NOTES BELOW.
- PHASE 3 E&S&C**
7. THE CONSTRUCTION ENTRANCE AND CULVERT (IF PRESENT), WILL BE REMOVED WHEN CONSTRUCTION ACTIVITIES CEASE ON THE PROJECT. THE REMOVED STONE AND SEDIMENT FROM THE ENTRANCE WILL BE HAULED OFF-SITE AND DISPOSED OF PROPERLY.
  8. UPON REMOVAL OF THE CONSTRUCTION ENTRANCE, THE CONTRACTOR SHALL BRING THE AREA TO ORIGINAL GRADE AND STABILIZE IT. IF A TEMPORARY CULVERT WAS UTILIZED IN CONJUNCTION WITH THE CONSTRUCTION ENTRANCE, THE CONTRACTOR SHALL INSTALL TEMPORARY MATTING AND SEDIMENT TUBE WITHIN ROADSIDE SWALE/DITCH.
  9. TEMPORARY MATTING SHALL BE NORTH AMERICAN GREEN BIONET SC150BN OR ENGINEER APPROVED EQUIVALENT.
  10. INSTALL THREE SEDIMENT TUBE IN EACH IMPACTED SWALE/DITCH; UPSTREAM, DOWNSTREAM, AND MIDDLE OF INTERSECTION OF SWALE/DITCH AND LIMITS OF DISTURBANCE. SEDIMENT TUBE SHALL BE 12-INCH (NOMINAL) STRAW WATTLE FOR CHANNELS LESS THAN 3 FEET IN DEPTH AND FOR CHANNELS GREATER THAN 3 FEET IN DEPTH, A 24-INCH WATTLE SHOULD BE USED.
- TEMPORARY CONSTRUCTION ENTRANCE MAINTENANCE**
1. INSPECT AT LEAST ONCE EVERY CALENDAR WEEK AND WITHIN 24 HOURS OF THE END OF A STORM EVENT OF 0.5-IN. OR GREATER IN 24 HOURS.
  2. THE ENTRANCE WILL BE MAINTAINED IN A CONDITION THAT WILL PREVENT TRACKING OR FLOWING OF SEDIMENT ONTO EXISTING ROADWAYS. SEDIMENT TRACKED, SPILLED, DROPPED OR OTHERWISE DEPOSITED ONTO ROADWAYS WILL BE SWEEPED UP AS SOON AS PRACTICAL AND PLACED BACK WITHIN THE APPROVED DISTURBED AREA.
  3. IF EXCESS SEDIMENT HAS CLOGGED THE STONE, THE ENTRANCE WILL BE TOPRESSED WITH NEW STONE AS NEEDED. REPLACEMENT OF THE STONE MAY BECOME NECESSARY WHEN THE STONE BECOMES ENTIRELY FILLED WITH SEDIMENT AND MUD.

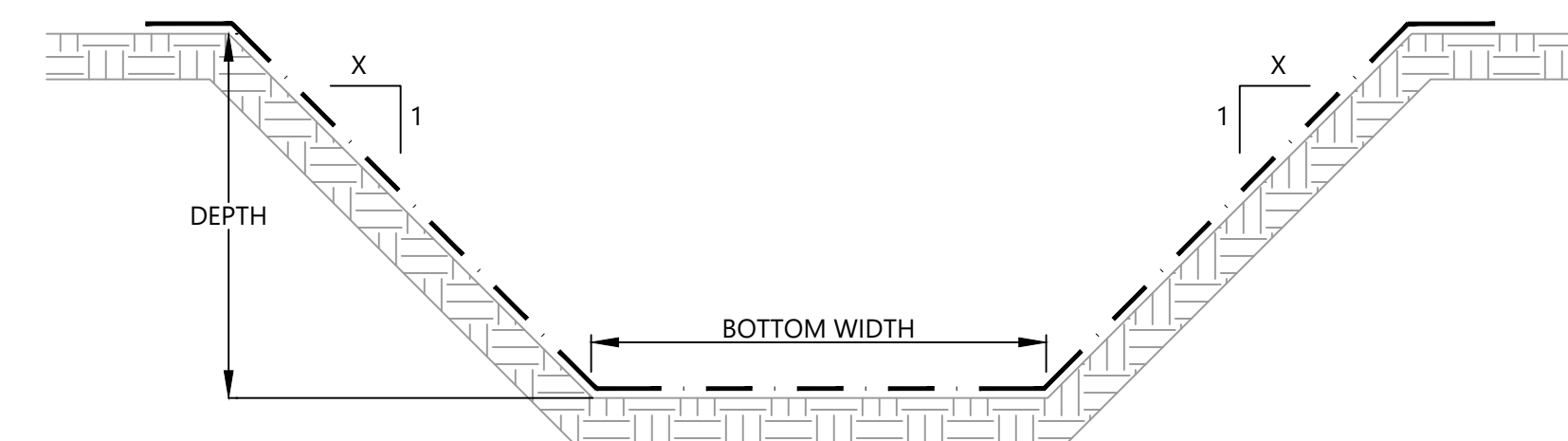

**CHANNEL NOTES:**

1. SEE PLAN SHEETS FOR CHANNEL LOCATION.
2. DIMENSIONING AND STABILIZATION MATTING ( NORTH AMERICAN GREEN S75 BN, SC 150BN OR P300 OR APPROVED EQUIVALENT) WILL BE DEFINED IN THE SWPPP FOR THE FACILITY.
3. SWPPP WILL PROVIDE DETAILED CHANNEL DESIGN.

CHANNEL SUMMARY TABLE						
CHANNEL ID	AVERAGE CHANNEL SLOPE (FT./FT.)	BOTTOM WIDTH (FT.)	LEFT SLOPE (XH:1V)	RIGHT SLOPE (XH:1V)	CHANNEL DEPTH (FT.)	CHANNEL MATTING
TYP.	0.0200	4	2	2	2	SC 150BN

2  
3 TYPICAL CHANNEL  
SCALE: N.T.S.

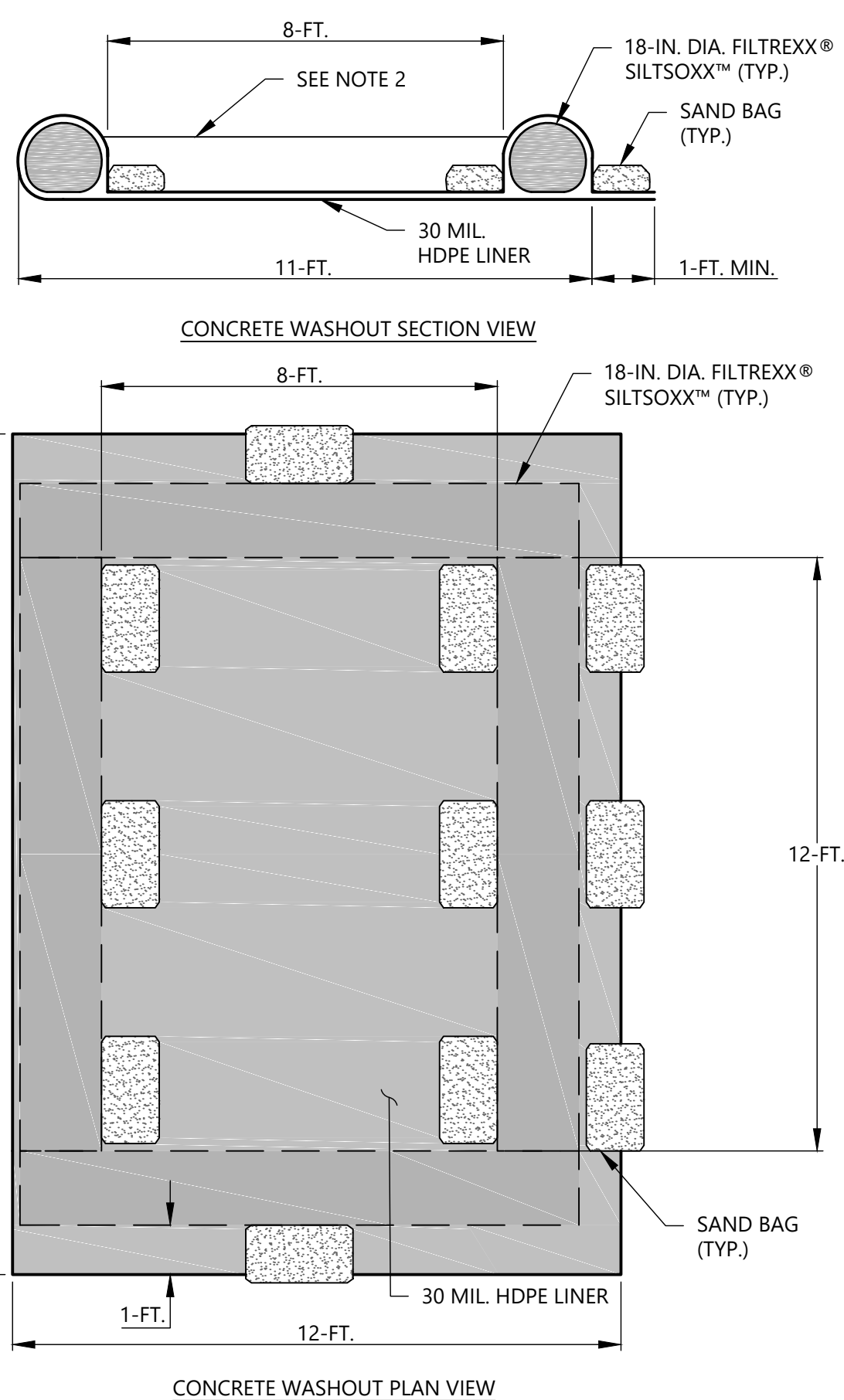

3  
3 CONCRETE WASHOUT  
SCALE: N.T.S.

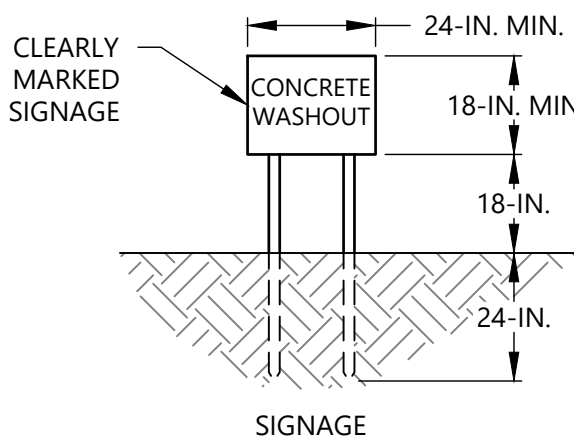

**CONCRETE WASHOUT NOTES:**

1. ACTUAL LOCATION DETERMINED IN FIELD.
2. THE CONCRETE WASHOUT STRUCTURES SHALL BE MAINTAINED WHEN THE LIQUID AND/OR SOLID REACHES 2/3 OF THE STRUCTURES CAPACITY TO PROVIDE ADEQUATE HOLDING CAPACITY WITH A MINIMUM 6-IN. OF FREEBOARD.
3. CONCRETE WASHOUT STRUCTURES REQUIRING ADDITIONAL CAPACITY SHALL INCLUDE EXCAVATED PIT BENEATH HDPE LINER OF WASHOUT RETENTION AREA. DEPTH OF PIT VARIES DEPENDING ON REQUIRED CAPACITY.
4. CONCRETE WASHOUT STRUCTURE NEEDS TO BE CLEARLY MARKED WITH SIGNAGE NOTING DEVICE.
5. DO NOT DISCHARGE CONCRETE OR CEMENT SLURRY FROM THE SITE.
6. DISPOSE OF, OR RECYCLE SETTLED, HARDENED CONCRETE RESIDUE IN ACCORDANCE WITH LOCAL AND STATE SOLID WASTE REGULATIONS AND AT AN APPROVED FACILITY.
7. MANAGE WASHOUT FROM MORTAR MIXERS IN ACCORDANCE WITH THE ABOVE ITEM AND IN ADDITION PLACE THE MIXER AND ASSOCIATED MATERIALS ON IMPERVIOUS BARRIER AND WITHIN LOT PERIMETER SILT FENCE.
8. INSTALL TEMPORARY CONCRETE WASHOUTS PER LOCAL REQUIREMENTS, WHERE APPLICABLE. IF AN ALTERNATE METHOD OR PRODUCT IS TO BE USED, CONTACT YOUR APPROVAL AUTHORITY FOR REVIEW AND APPROVAL. IF LOCAL STANDARD DETAILS ARE NOT AVAILABLE, USE ONE OF THE TWO TYPES OF TEMPORARY CONCRETE WASHOUTS PROVIDED ON THIS DETAIL.

8. DO NOT USE CONCRETE WASHOUTS FOR DEWATERING OR STORING DEFECTIVE CURB OR SIDEWALK SECTIONS. STORMWATER ACCUMULATED WITHIN THE WASHOUT MAY NOT BE PUMPED INTO OR DISCHARGED TO THE STORM DRAIN SYSTEM OR RECEIVING SURFACE WATERS. LIQUID WASTE MUST BE PUMPED OUT AND REMOVED FROM PROJECT.
9. LOCATE WASHOUTS AT LEAST 50-FT. FROM STORM DRAIN INLETS AND SURFACE WATERS UNLESS IT CAN BE SHOWN THAT NO OTHER ALTERNATIVES ARE REASONABLY AVAILABLE. AT A MINIMUM, INSTALL PROTECTION OF STORM DRAIN INLET(S) CLOSEST TO THE WASHOUT WHICH COULD RECEIVE SPILLS OR OVERFLOW.
10. LOCATE WASHOUTS IN AN EASILY ACCESSIBLE AREA, ON LEVEL GROUND AND INSTALL A STONE ENTRANCE PAD IN FRONT OF THE WASHOUT. ADDITIONAL CONTROLS MAY BE REQUIRED BY THE APPROVING AUTHORITY.
11. INSTALL AT LEAST ONE SIGN DIRECTING CONCRETE TRUCKS TO THE WASHOUT WITHIN THE PROJECT LIMITS. POST SIGNAGE ON THE WASHOUT ITSELF TO IDENTIFY THIS LOCATION.
12. REMOVE LEAVINGS FROM THE WASHOUT WHEN AT APPROXIMATELY 2/3 CAPACITY TO LIMIT OVERFLOW EVENTS. REPLACE THE HDPE LINER, SAND BAGS OR OTHER TEMPORARY STRUCTURAL COMPONENTS WHEN NO LONGER FUNCTIONAL. WHEN UTILIZING ALTERNATIVE OR PROPRIETARY PRODUCTS, FOLLOW MANUFACTURER'S INSTRUCTIONS.
13. AT THE COMPLETION OF THE CONCRETE WORK, REMOVE REMAINING LEAVINGS AND DISPOSE IN AN APPROVED DISPOSAL FACILITY. STABILIZE ANY DISTURBANCE CAUSED BY REMOVAL OF WASHOUT.

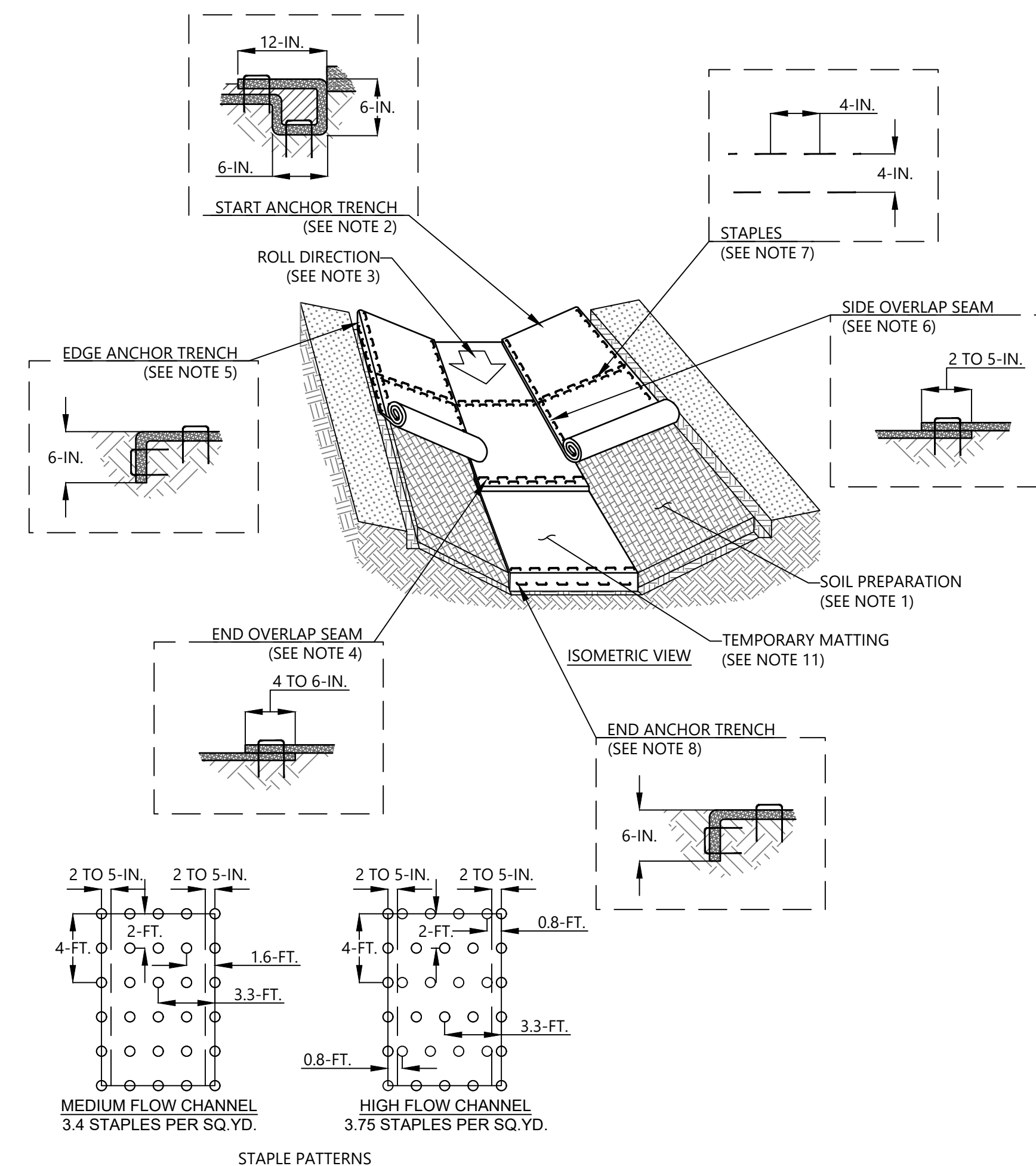

**TEMPORARY MATTING NOTES**

1. PREPARE SOIL BEFORE INSTALLING ROLLED EROSION CONTROL PRODUCTS (RECPS), INCLUDING ANY NECESSARY APPLICATION OF LIME, FERTILIZER, AND SEED.
2. BEGIN AT THE TOP OF THE CHANNEL BY ANCHORING THE RECPS IN A 6-INCH DEEP BY 6-IN. WIDE TRENCH WITH APPROXIMATELY 12-IN. OF RECPS EXTENDED BEYOND THE UP-SLOPE PORTION OF THE TRENCH. USE SHOREMAX MAT AT THE CHANNEL/CULVERT OUTLET AS SUPPLEMENTAL SCOUR PROTECTION AS NEEDED. ANCHOR THE RECPS WITH A ROW OF STAPLES/STAKES APPROXIMATELY 12-IN. APART IN THE BOTTOM OF THE TRENCH. BACKFILL AND COMPACT THE TRENCH AFTER STAPLING. APPLY SEED TO THE COMPACTED SOIL AND FOLD THE REMAINING 12-IN. PORTION OF RECPS BACK OVER THE SEED AND COMPACTED SOIL. SECURE RECPS OVER COMPACTED SOIL WITH A ROW OF STAPLES/STAKES SPACED APPROXIMATELY 12-IN. APART ACROSS THE WIDTH OF THE CHANNEL.
3. ROLL CENTER RECPS IN DIRECTION OF WATER FLOW IN BOTTOM OF CHANNEL. RECPS WILL UNROLL WITH APPROPRIATE SIDE AGAINST THE SOIL SURFACE. ALL RECPS MUST BE SECURELY FASTENED TO SOIL SURFACE BY PLACING STAPLES/STAKES IN APPROPRIATE LOCATIONS AS SHOWN IN THE STAPLE PATTERN GUIDE.
4. PLACE CONSECUTIVE RECPS END-OVER-END (SHINGLE STYLE) WITH A 4 TO 6-IN. OVERLAP. USE A DOUBLE ROW OF STAPLES STAGGERED 4-IN. APART AND 4-INCH ON CENTER TO SECURE RECPS.
5. FULL LENGTH EDGE OF RECPS AT TOP OF SIDE SLOPES MUST BE ANCHORED WITH A ROW OF STAPLES/STAKES APPROXIMATELY 12-IN. APART IN A 6-IN. DEEP X 6-IN. WIDE TRENCH. BACKFILL AND COMPACT THE TRENCH AFTER STAPLING.
6. ADJACENT RECPS MUST BE OVERLAPPED APPROXIMATELY 2 TO 5-IN. (DEPENDING ON RECPS TYPE) AND STAPLED.
7. IN HIGH FLOW CHANNEL APPLICATIONS A STAPLE CHECK SLOT IS RECOMMENDED AT 30 TO 40-FT. INTERVALS. USE A DOUBLE ROW OF STAPLES STAGGERED 4-IN. APART AND 4-IN. ON CENTER OVER ENTIRE WIDTH OF THE CHANNEL.
8. THE TERMINAL END OF THE RECPS MUST BE ANCHORED WITH A ROW OF STAPLES/STAKES APPROXIMATELY 12-IN. APART IN A 6-IN. DEEP BY 6-IN. WIDE TRENCH. BACKFILL AND COMPACT THE TRENCH AFTER STAPLING.
9. HORIZONTAL STAPLE SPACING SHOULD BE ALTERED IF NECESSARY TO ALLOW STAPLES TO SECURE THE CRITICAL POINTS ALONG THE CHANNEL SURFACE.
10. IN LOOSE SOIL CONDITIONS, THE USE OF STAPLE OR STAKE LENGTHS GREATER THAN 6-IN. MAY BE NECESSARY TO PROPERLY SECURE THE RECPS.
11. TEMPORARY MATTING SHALL BE NORTH AMERICAN GREEN OR ENGINEER APPROVED EQUIVALENT. REFER TO PLAN VIEW DRAWINGS FOR NORTH AMERICAN GREEN'S PRODUCT NAME FOR SPECIFIC GRADE OF TEMPORARY MATTING FOR EACH ROADSIDE SWALE/DITCH.

**TEMPORARY MATTING MAINTENANCE**

1. REGULAR INSPECTIONS OF TEMPORARY MATTING SHALL BE CONDUCTED ONCE EVERY CALENDAR WEEK AND, AS RECOMMENDED, WITHIN 24-HOURS AFTER EACH RAINFALL EVENT THAT PRODUCES 1/2-INCH OR MORE OF PRECIPITATION. MAKE ANY NECESSARY REPAIRS IMMEDIATELY.
2. GOOD CONTACT WITH THE GROUND MUST BE MAINTAINED, AND EROSION MUST NOT OCCUR BENEATH THE RECPS.
3. ANY AREAS OF THE RECPS THAT ARE DAMAGED OR NOT IN CLOSE CONTACT WITH THE GROUND SHALL BE REPAIRED AND STAPLED.
4. IF EROSION OCCURS DUE TO POORLY CONTROLLED DRAINAGE, THE PROBLEM SHALL BE FIXED AND THE ERODED AREA PROTECTED.
5. MONITOR AND REPAIR THE RECPS AS NECESSARY UNTIL GROUND COVER IS ESTABLISHED.

4  
3 CHANNEL MATTING  
SCALE: N.T.S.

NO.	DATE	BY	CHK	APV	DESCRIPTION

DETAILS (SHEET 1 OF 4)

FAIRFIELD-177 DEVELOPMENT SITE, E&S&C PLAN - INITIAL PHASE  
LUCK STONE CORPORATION  
FAIRFIELD COUNTY, SOUTH CAROLINA

PROJECT NUMBER  
210730C  
DRAWING NUMBER



**SEDIMENTATION BASIN CONSTRUCTION SPECIFICATIONS**

- 1. BASIN PREPARATIONS:** PLACE TEMPORARY EROSION AND SEDIMENT CONTROL MEASURES PER THE PLANS. CLEAR, GRUB AND STRIP TOPSOIL FROM THE EMBANKMENT TO REMOVE VEGETATION, STUMPS, ROOTS, ORGANIC MATERIAL, TRASH, ROCK MATERIAL AND OTHER OBJECTIONABLE MATERIAL. REMOVE SEDIMENT, PERVIOUS MATERIAL, ORGANIC MATERIAL TO THE DESIGN ELEVATION AND DIMENSIONS OF THE BASIN. KEEP BASIN DRY DURING CONSTRUCTION ACTIVITIES. THE FLOOR OF THE BASIN SHALL BE GRADED TO THE FINAL ELEVATION SHOWN ON THE DRAWINGS AND GRADED BASIN SHALL BE COMPACTED WITH A MINIMUM 10-TON SMOOTH DRUM (NON-VIBRATORY) COMPACTOR AND THEN PROOF-ROLLED. PROOF-ROLL THE ENTIRE SEDIMENTATION BASIN FLOOR. THE PROOF ROLLING SHALL BE OBSERVED AND EVALUATED BY THE ENGINEER OR HIS REPRESENTATIVE.
- 2. PRINCIPAL SPILLWAY, BARREL AND SKIMMER:** CONSTRUCT THE BARREL ACCORDING TO THE BELOW TEMPORARY SEDIMENT BASIN DETAIL. SECURE ALL CONNECTIONS BETWEEN BARREL AND RISER SECTIONS BY APPROVED WATERTIGHT ASSEMBLIES. ATTACH BASIN SKIMMER TO RISER BY APPROVED WATERTIGHT ASSEMBLIES (SEE SKIMMER DETAIL 13). DO NOT USE PERVIOUS MATERIAL SUCH AS SAND, GRAVEL, SILT, OR CRUSHED STONE AS BACKFILL MATERIAL AROUND THE PIPE. PLACE THE FILL MATERIAL AROUND THE PIPE SPILLWAY IN 4-IN. LOOSE LAYERS AND COMPACT IT AROUND THE PIPE TO 95 PERCENT OR GREATER AS THE REST OF THE EMBANKMENT FILL. CARE MUST BE TAKEN NOT TO RAISE THE PIPE FROM FIRM CONTACT WITH ITS FOUNDATION WHEN COMPACTING UNDER THE PIPE HAUNCHES. PLACE A MINIMUM DEPTH OF TWO FEET OF HAND COMPACTED BACKFILL OVER THE PIPE SPILLWAY BEFORE CROSSING THE PIPE WITH COMPACTION EQUIPMENT OR CONSTRUCTION EQUIPMENT.
- 3. EMBANKMENT CONSTRUCTION:** USE CLEAN FILL MATERIAL BROUGHT TO SITE OR EXCAVATED FROM APPROVED AREAS ON SITE. IT SHALL BE CLEAN MINERAL SOIL, FREE OF ROOTS, WOODY VEGETATION, ROCKS AND OTHER OBJECTIONABLE MATERIAL. SCARIFY AREAS AND EACH COMPACTED LIFT ON WHICH FILL IS TO BE PLACED BEFORE PLACING THE FILL. THE FILL OPTIMUM MOISTURE CONTENT SHALL BE MAINTAINED BETWEEN OPTIMUM AND THREE PERCENT ABOVE OPTIMUM. FILL SHALL BE COMPACTED NOT LESS THAN 95 PERCENT OF THE MAXIMUM DRY DENSITY AS DETERMINED BY ASTM D698 METHOD A. THE CONTRACTOR SHALL DEMONSTRATE SOIL DENSITY BY SOIL COMPACTION PER THE PLANS AND SPECIFICATIONS WITH A MINIMUM OF TWO DENSITY TESTS PER LIFT WITH TESTS SPACED EVENLY AND REPRESENTATIVE OF THE EMBANKMENT FILL. ONE FAILED TEST REQUIRES THAT THE LIFT BE RE-COMPACTED AND RE-TESTED AT TWO LOCATIONS UNTIL REQUIRED COMPACTION IS ACHIEVED. NO VEGETATIVE COVER MATERIAL SHALL BE PLACED ON COMPACTED FILL LAYERS BEFORE THE ENGINEER REVIEWS AND APPROVES THE DENSITY DATA FROM THE TESTING PERFORMED. THE ENGINEER MAY EVALUATE COMPACTION AND REPORT THE RESULTS TO THE CONTRACTOR. FAILED SOIL DENSITY TESTS PERFORMED BY THE ENGINEER WILL REQUIRE THAT THE COMPACTED MATERIAL BE REMOVED AND RE-INSTALLED PER THE PLANS AND SPECIFICATIONS.
- 4. OUTLET DISCHARGE:** EFFLUENT FROM THE PRINCIPAL SPILLWAY BARREL FROM THE SEDIMENT BASIN. SHALL HAVE AN ANTI-SEEP COLLAR SLIGHTLY DOWNSTREAM FROM THE DAM CENTER LINE. SHALL DISCHARGE TO A PLUNGE POOL. SEE DETAIL 10.
- 5. EMERGENCY SPILLWAY:** INSTALL THE EMERGENCY SPILLWAY IN THE UNDISTURBED SOIL. TOLERANCE TO DESIGN ELEVATIONS IS +/- 0.2 FEET; TOLERANCE TO DESIGN GRADES IS +/- 1.0 PERCENT; AND TOLERANCE FOR WIDTHS AND LENGTHS IS +/- 1.0-FT. NO DEVIATION FROM THE SPECIFIED TOLERANCES SHALL BE ALLOWED. LINE THE SPILLWAY WITH LAMINATED PLASTIC OR IMPERMEABLE GEOTEXTILE FABRIC. THE FABRIC SHALL HAVE DIMENSIONS LARGE ENOUGH TO COVER THE BOTTOM AND SIDES AND EXTEND ONTO THE TOP OF THE DAM FOR ANCHORING IN A TRENCH. THE EDGES SHALL BE SECURED WITH 8-IN. STAPLES OR PINS. THE FABRIC MUST BE LONG ENOUGH TO EXTEND DOWN THE SLOPE AND EXIT ONTO STABLE GROUND. THE WIDTH OF THE FABRIC SHALL BE ONE PIECE, TO PREVENT WATER FROM ACCESS BENEATH THE FABRIC; JOINING OR SPLICING OF SECTIONS ACROSS THE WIDTH SHALL NOT BE ALLOWED. THE LENGTH OF THE FABRIC MAY BE COMPOSED OF SECTIONS SPANNING THE ENTIRE SPILLWAY WIDTH. UPPER SECTIONS SHALL OVERLAP LOWER SECTIONS SO THAT WATER CANNOT FLOW UNDER THE FABRIC. SECURE THE UPPER EDGE AND SIDES OF THE FABRIC IN A TRENCH WITH STAPLES OR PINS (ADAPTED FROM "A MANUAL FOR DESIGNING AND MAINTAINING SKIMMER SEDIMENT BASINS" FEBRUARY, 1999 J.W. FAIRCLOTH & SON). A 6-IN. VEGETATIVE COVER SHALL BE PLACED ON TOP OF THE GEOTEXTILE FABRIC. EROSION CONTROL MATTING SHALL BE PLACED ON TOP OF THE VEGETATIVE LAYER.
- 6. INLETS:** INSTALL INLETS TO DISCHARGE WATER INTO THE FOREBAYS IN A MANNER TO PREVENT EROSION.
- 7. EROSION CONTROL:** CONSTRUCT THE STRUCTURE SO THAT THE DISTURBED AREA IS MINIMIZED. DIVERT SURFACE WATER AWAY FROM THE BARE AREAS. COMPLETE THE EMBANKMENT BEFORE ADDITIONAL UPSTREAM AREA IS CLEARED. STABILIZE THE EMERGENCY SPILLWAY EMBANKMENT AND ALL OTHER DISTURBED AREAS ABOVE THE CREST OF THE PRINCIPAL SPILLWAY IMMEDIATELY AFTER CONSTRUCTION (REFERENCES: SURFACE STABILIZATION).

**MAINTENANCE**

- CHECK SEDIMENT BASIN AFTER PERIODS OF SIGNIFICANT RUNOFF. REMOVE SEDIMENT AND RESTORE THE BASIN TO ITS ORIGINAL DIMENSIONS WHEN SEDIMENT ACCUMULATES TO ONE-HALF THE DESIGN DEPTH AS MARKED BY THE SEDIMENT CLEANOUT STAKE.
- CHECK THE EMBANKMENT, SPILLWAYS AND OUTLET FOR EROSION DAMAGE AND EVALUATE THE EMBANKMENT FOR PIPING AND SETTLEMENT. MAKE ALL NECESSARY REPAIRS IMMEDIATELY. REMOVE ALL TRASH AND DEBRIS FROM THE RISER AND POOL AREA.

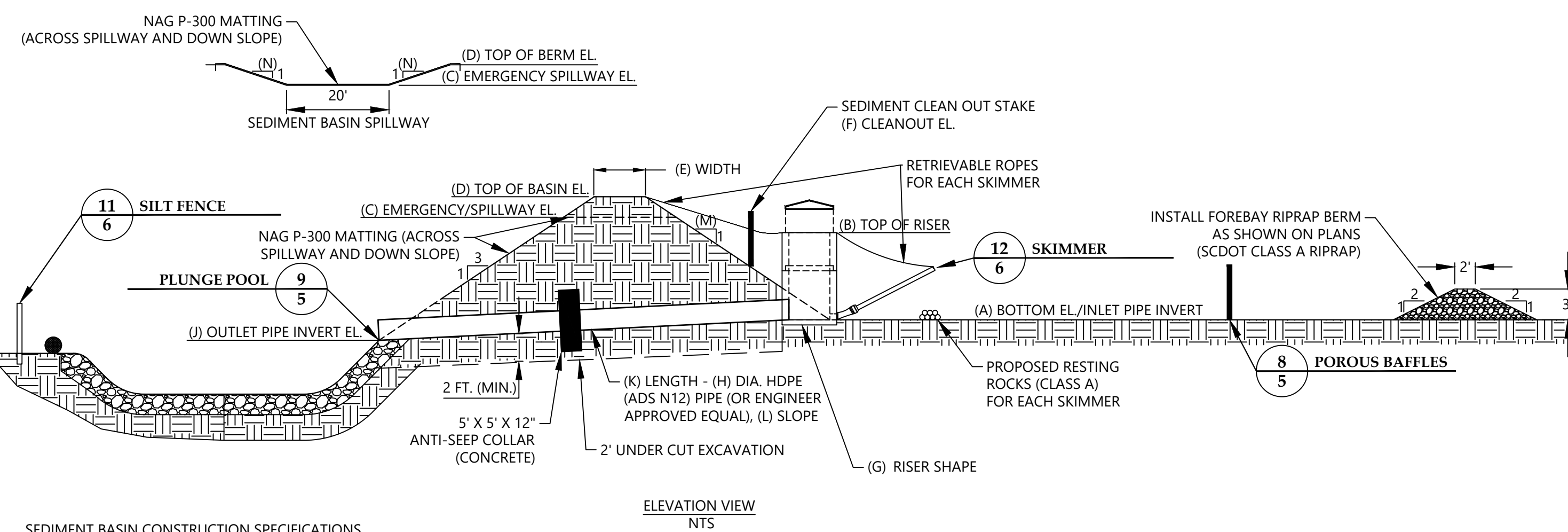

**SEDIMENT BASIN CONSTRUCTION SPECIFICATIONS**

1. ASSEMBLE THE SKIMMER AS DESIGNED (SKIMMER DETAIL 13).
2. LAY THE ASSEMBLED SKIMMER ON THE BOTTOM OF THE BASIN. SECURE THE CONNECTIONS BETWEEN THE INLET BASIN SKIMMER FLEXIBLE JOINT TO THE RISER ORIFICE BY APPROVED WATERTIGHT ASSEMBLIES. POSITION THE SKIMMER OVER THE SUPPORT PAD. ATTACH A ROPE TO THE SKIMMER AND ANCHOR IT TO THE SIDE OF THE BASIN FOR ACCESS TO THE SKIMMER FOR FUTURE MAINTENANCE.

**MAINTENANCE**

INSPECT THE SEDIMENTATION BASIN AT LEAST WEEKLY AND AFTER EACH SIGNIFICANT (ONE HALF INCH OR GREATER) RAINFALL EVENT AND REPAIR IMMEDIATELY. REMOVE SEDIMENT AND RESTORE THE BASIN TO ITS ORIGINAL DIMENSIONS WHEN SEDIMENT ACCUMULATES TO ONE-HALF THE HEIGHT OF THE FIRST BAFFLE. PULL THE SKIMMER TO ONE SIDE TO ACCESS SEDIMENT BELOW FOR REMOVAL. EXCAVATE THE SEDIMENT FROM THE ENTIRE BASIN, NOT LIMITED TO THE SKIMMER LOCATION OR WITHIN THE FIRST BASIN CELL. CUT OR REMOVE VEGETATION FROM THE BOTTOM OF THE BASIN THAT LIMITS OPERATION OF THE SKIMMER OR RESTRICTS ITS ABILITY TO FLOAT.

REPAIR DAMAGED BAFFLES. RE-ANCHOR BAFFLES IF WATER IS FLOWING UNDERNEATH OR AROUND THEM.

REMOVE CLOGS FROM SKIMMER BY JERKING ON THE ROPE TO BOB THE SKIMMER, OR PULL THE SKIMMER TO ONE SIDE OF THE BASIN AND REMOVE THE DEBRIS. CHECK THE ORIFICE INSIDE THE SKIMMER FOR DEBRIS. IF PRESENT, REMOVE THE DEBRIS. IF THE SKIMMER ARM OR BARREL IS CLOGGED, REMOVE THE ORIFICE AND FLUSH WITH WATER TO RESTORE FLOW, OR USE A PLUMBERS SNAKE TO REMOVE THE CLOG. REPLACE THE ORIFICE BEFORE REPOSITIONING THE SKIMMER.

CHECK THE FABRIC LINED SPILLWAY FOR DAMAGE AND MAKE REQUIRED REPAIRS WITH FABRIC THAT SPANS THE FULL WIDTH OF THE SPILLWAY. CHECK THE EMBANKMENT, SPILLWAYS, AND OUTLET FOR EROSION DAMAGE, AND INSPECT THE EMBANKMENT FOR PIPING AND SETTLEMENT. MAKE NECESSARY REPAIRS IMMEDIATELY. REMOVE ALL TRASH AND OTHER DEBRIS FROM THE SKIMMER, RISER, AND POOL AREAS.

FREEZING WEATHER CAN RESULT IN ICE FORMING IN THE BASIN. PREVENT ICE FROM CLOGGING THE SKIMMER.

AFTER ALL SEDIMENT-PRODUCING AREAS HAVE BEEN PERMANENTLY STABILIZED; REMOVE THE SKIMMER, BAFFLES, 30 MIL LINER, STAINLESS STEEL STRAP, HYDRAULIC TAPE, AND ALL UNSTABLE SEDIMENT IN THE BASINS.

**SEDIMENT BASIN SUMMARY TABLE**

SEDIMENT BASIN ID	A	B	C	D	E	F	G	H	I	J	K	L	M	N
SEDIMENT BASIN ID	BOTTOM OF BASIN ELEVATION (FT.)	TOP OF RISER ELEVATION (FT.)	EMERGENCY SPILLWAY CREST ELEVATION (FT.)	TOP OF BERM ELEVATION (FT.)	TOP OF BERM WIDTH (FT.)	CLEAN OUT ELEVATION (FT.)	RISER SHAPE (FT. X FT.)	OUTLET PIPE DIAMETER (DO) (FT.)	OUTLET PIPE UPSTREAM INV. ELEVATION (FT.)	OUTLET PIPE DOWNSTREAM INV. ELEVATION (FT.)	LENGTH OF OUTLET PIPE (FT.)	SLOPE OF OUTLET PIPE (%)	INTERIOR SIDE SLOPES (Z FT. X 1 FT.)	EMERGENCY SPILLWAY INTERIOR SIDE SLOPES (Z FT. X 1 FT.)
PT-SB-1	557.0	562.7	563.7	565.0	12	560.1	3x3	2	557.0	556.0	100	1.0	3:1	3:1
W-SB-1	500.0	505.4	506.4	508.0	12	503.0	3x3	2	500.0	499.0	100	1.0	3:1	3:1
P-SB-1	450.0	457.4	458.4	460.0	12	454.1	3x3	2	450.0	449.0	100	1.0	3:1	3:1
P-SB-2	481.0	487.4	488.4	490.0	12	484.6	3x3	2	481.0	480.0	100	1.0	3:1	3:1
P-SB-3	490.0	497.3	498.3	500.0	12	494.1	3x3	2	490.0	489.0	100	1.0	3:1	3:1
NE-SB-1	427.0	434.4	435.4	437.0	12	431.3	3x3	2	427.0	426.0	100	1.0	3:1	3:1
NE-SB-2	412.0	416.8	417.8	420.0	12	414.7	3x3	2	412.0	411.0	100	1.0	3:1	3:1
NE-SB-3	412.0	418	419	421.0	12	415.4	3x3	2	412.0	411.0	100	1.0	3:1	3:1
NE-SB-4	479.0	484.5	485.5	487.0	12	481.0	3x3	2	479.0	478.0	100	1.0	3:1	3:1

**5 SEDIMENT BASIN SCALE: N.T.S.**

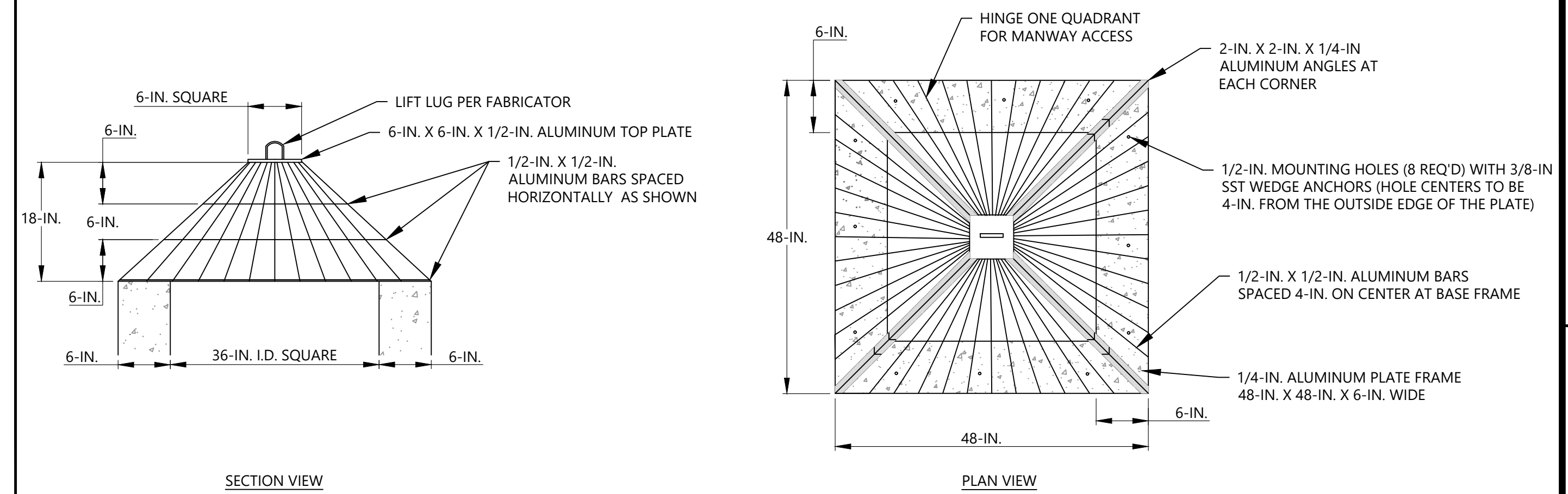

**6 TRASH RACK SCALE: N.T.S.**

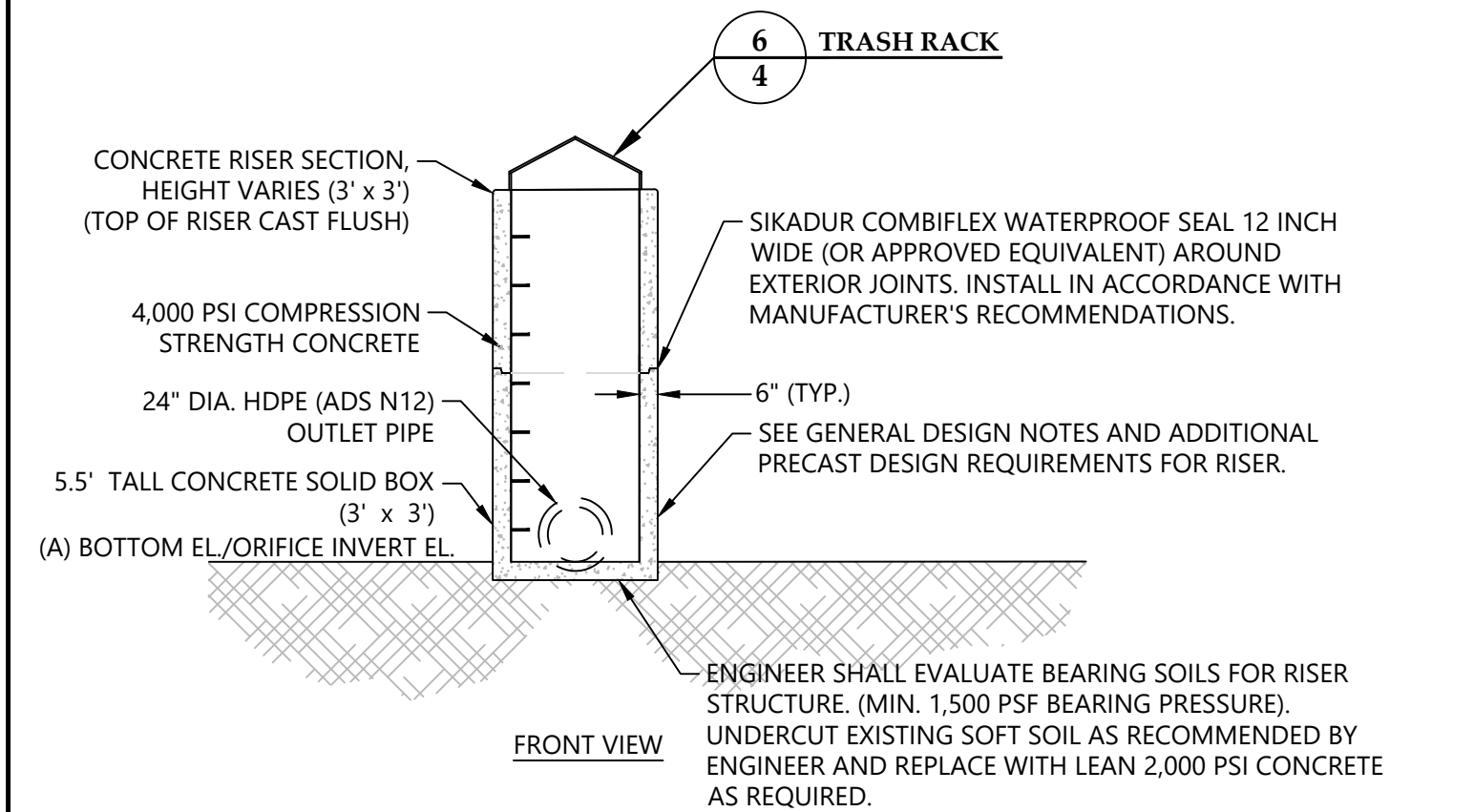

**ADDITIONAL PRECAST DESIGN REQUIREMENTS**

1. RISER SHALL BE DESIGNED FOR A WATER PRESSURE OF 1,300 PSF AND HORIZONTAL SOIL PRESSURE OF 700 PSF. (TOTAL HORIZONTAL PRESSURE OF 2,000 PSF).
2. STRENGTH DESIGN METHOD IN ACCORDANCE WITH (I.A.W.) ACI318.
3. APPLICABLE DESIGN DOCUMENTS (CURRENT EDITIONS):
  - ACI318 BUILDING CODE REQUIREMENTS FOR STRUCTURAL CONCRETE (MAIN DESIGN SPECIFICATIONS).
  - ASTM C890 STANDARD PRACTICE FOR MINIMUM STRUCTURAL LOADING FOR MONOLITHIC OR SECTIONAL PRECAST CONCRETE WATER AND WASTEWATER STRUCTURES (LOADING SPECIFICATIONS).
  - ASTM C913 STANDARD SPECIFICATIONS FOR PRECAST CONCRETE AND WATER AND WASTEWATER STRUCTURES.
4. MAX DEPTH TO INVERT OF PRECAST (I.E. FLOOR) = 15' FOR SOLID BASE AND 10 FOR WAFFLE BASE.
5. GWT ASSUMED BELOW INVERT OF PRECAST.
6. LATERAL DESIGN PRESSURES (AS APPLICABLE TO DESIGN):
  - EQUIV DRY SOIL FLUID PRESSURE = 47 PCF.
  - EQUIV SATURATED SOIL FLUID PRESSURE = 85 PCF.
  - LIVE LOAD SURCHARGE = 80 PSF.
7. DESIGN CONCRETE COMPRESSIVE STRENGTH AT 28 DAYS = 4,000 PSI (MIN.)
8. REINFORCEMENT:
  - CARBON-STEEL DEFORMED BARS: ASTM A615, fy = 60 KSI (MIN.)
  - WELDED WIRE REINFORCEMENT (DEFORMED): ASTM A1064 fy = 70 KSI (MIN.)
9. COPOLYMER POLY PROPYLENE STEEL REINFORCED STEPS I.A.W. ASTM C478 SPACED 16" O.C.
10. LIFT LOOPS, PINS OR UTILITY ANCHORS PROVIDED FOR HANDLING. CONTRACTOR SHALL BE RESPONSIBLE FOR FOLLOWING OLD CASTLE PRECAST, INC. LIFTING INSTRUCTIONS AS SHOWN ON BACK OF SHIPPING TICKET.

**CONCRETE RISER SUMMARY TABLE**

SEDIMENT BASIN ID	A	B	C
SEDIMENT BASIN ID	BOTTOM EL./ORIFICE INVERT EL. (FT.)	RISER SECTION HEIGHT (FT.)	ORIFICE SIZE (IN.)
PT-SB-1	557'	2'	8"
W-SB-1	500'	0' (NOT USED)	7"
P-SB-1	450'	2'	(2) 8"
P-SB-2	481'	2'	7"
P-SB-3	490'	2'	8"
NE-SB-1	427'	2'	8"
NE-SB-2	412'	0' (NOT USED)	6"
NE-SB-3	412'	2'	6"
NE-SB-4	479'	0' (NOT USED)	8"

**7 CONCRETE RISER SCALE: N.T.S.**

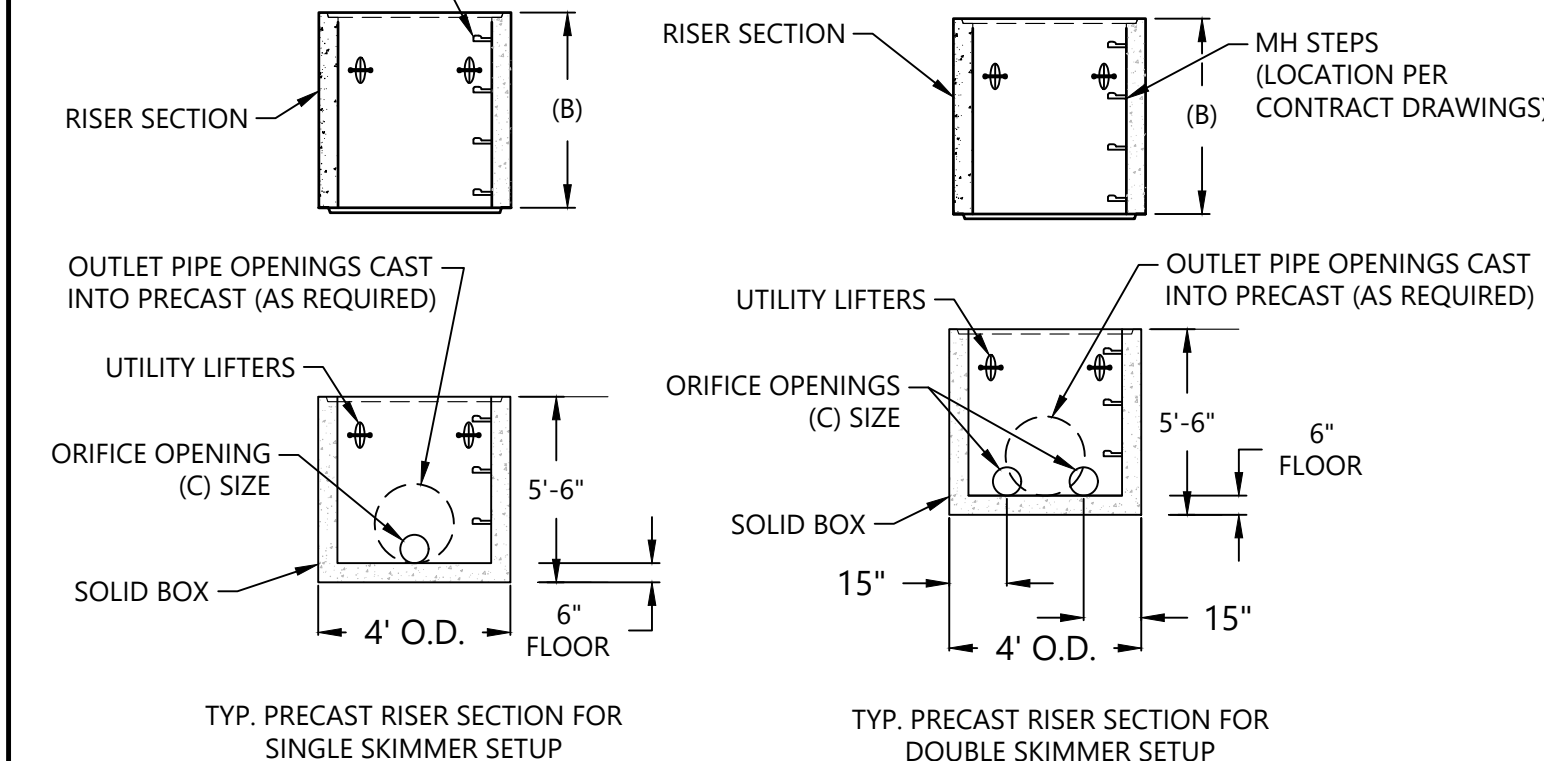

DRAWING PATH: R:\CADD\Draw\Chloe\177\177.DWG\EG&C\DETAILS (SHEET 2 OF 4).dwg



9751 SOUTHERN PINE BLVD  
CHARLOTTE, NC 28273  
(704) 523-4726

ENGINEERING FIRM  
LICENSE NUMBER: F-0176

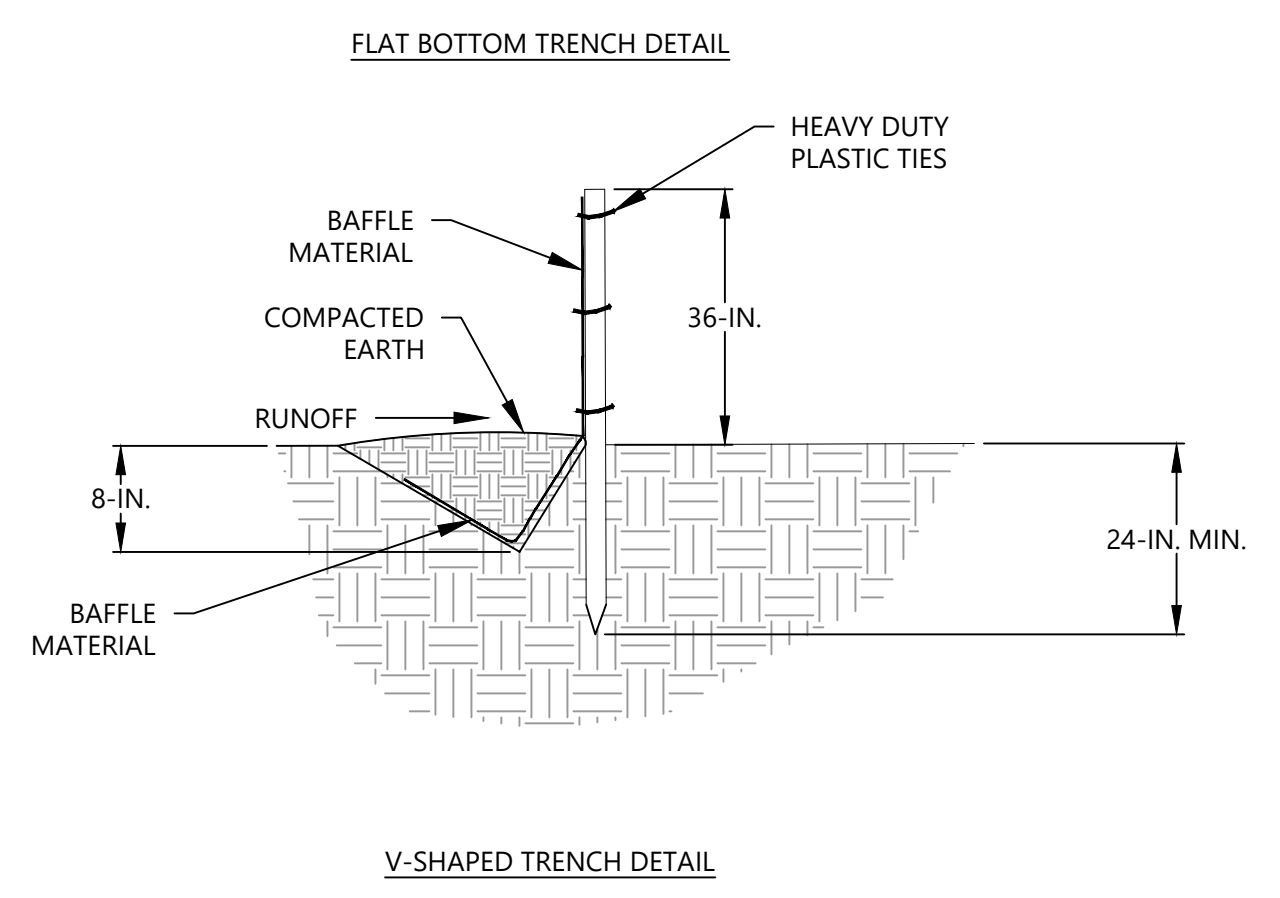
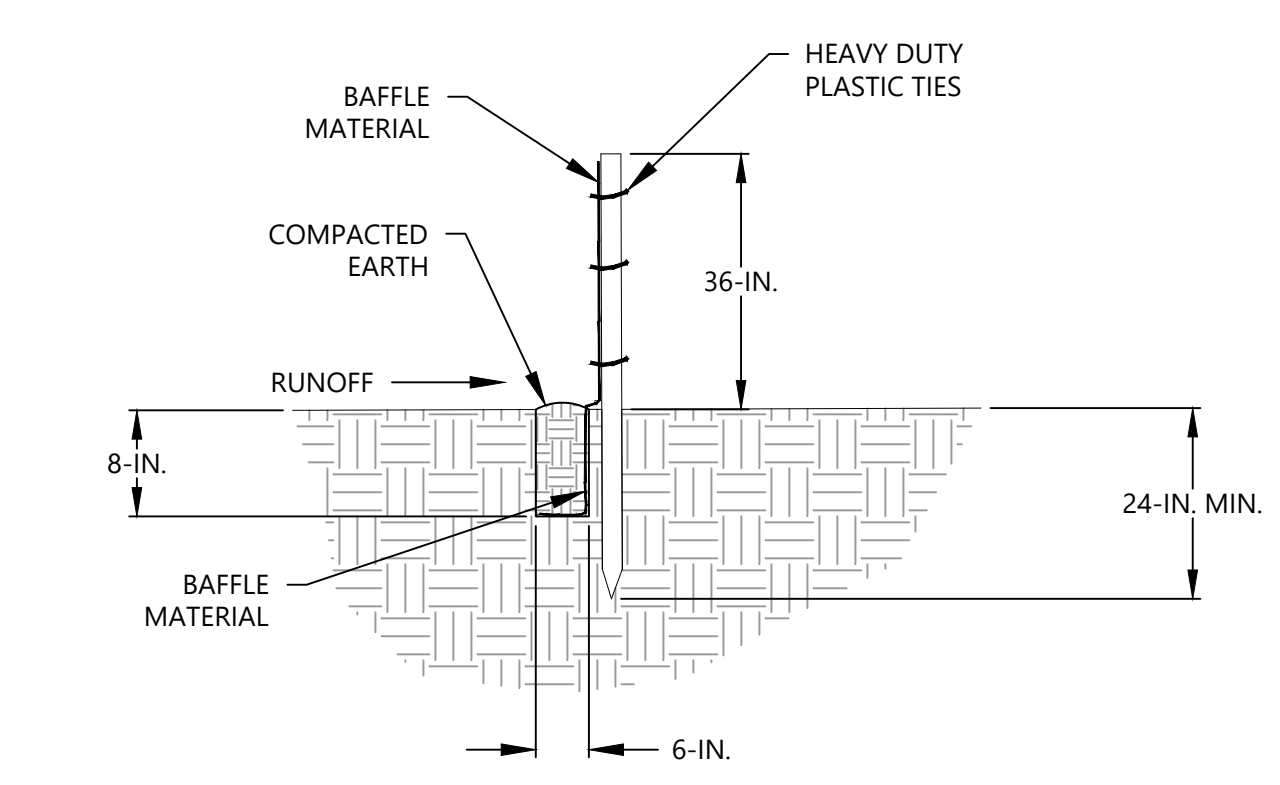
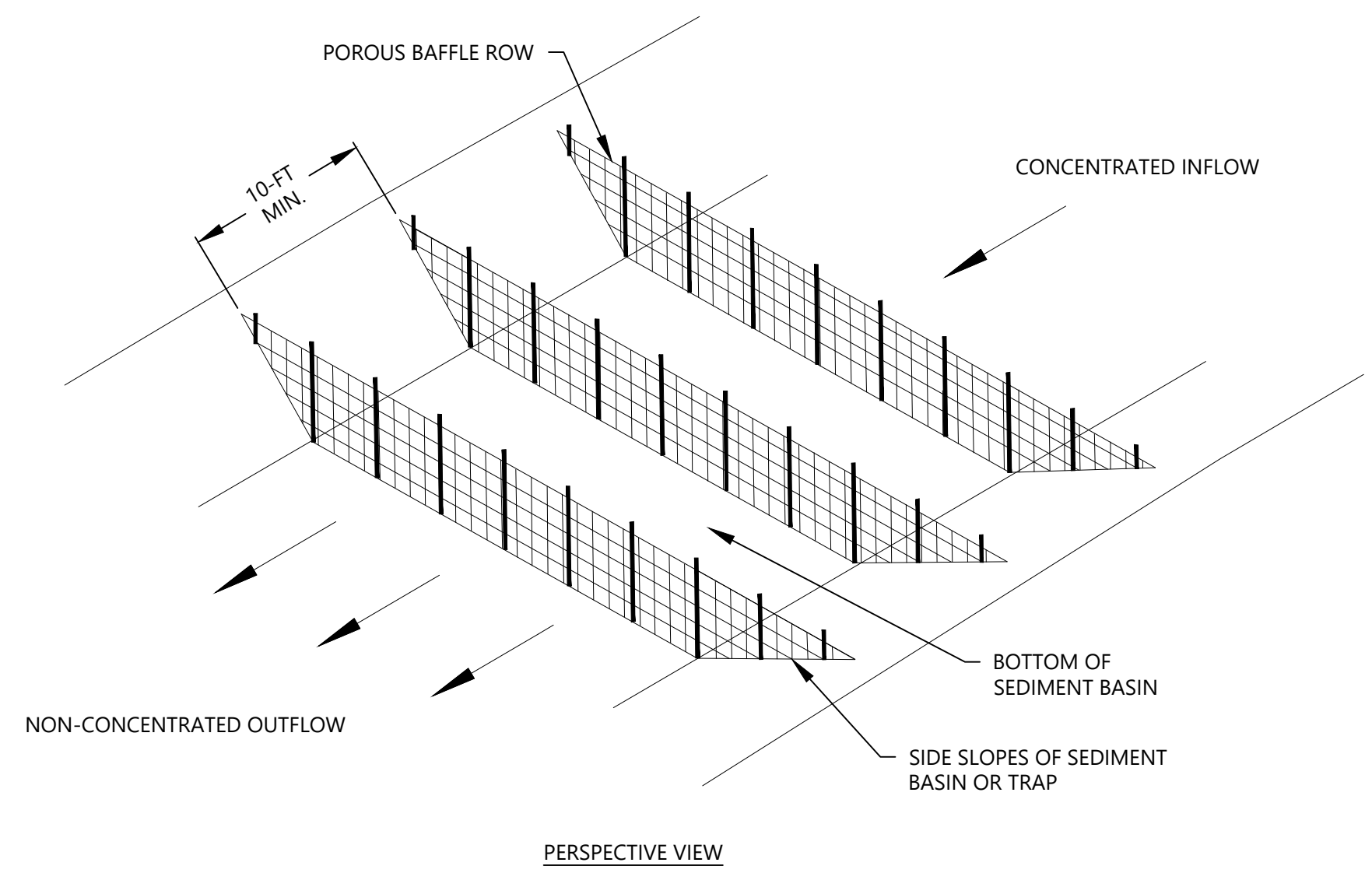
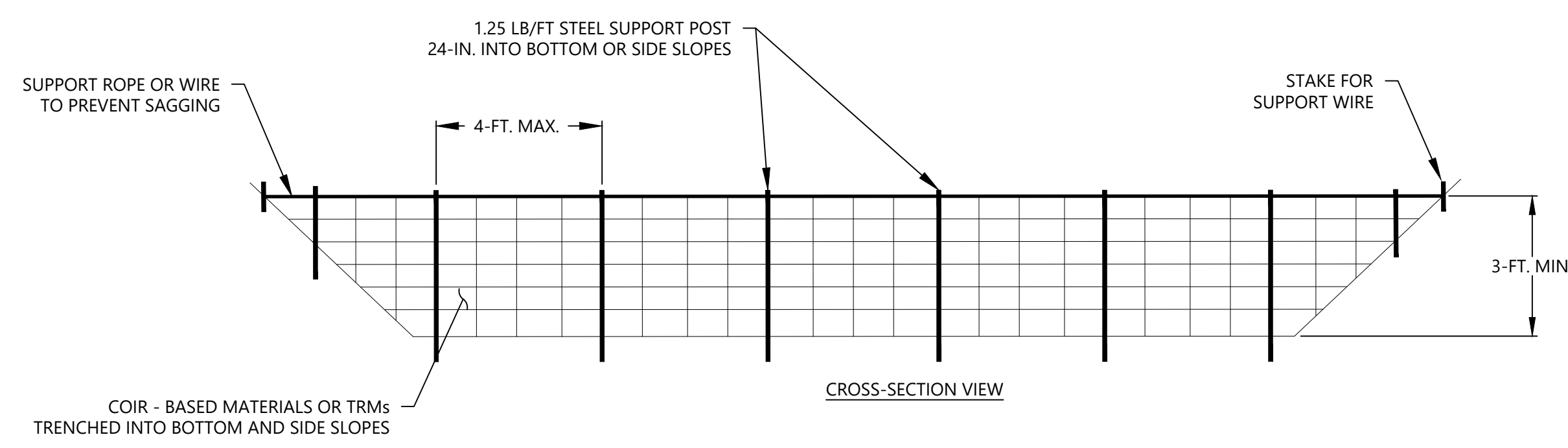

**BAFFLES - POST REQUIREMENTS**

- POROUS BAFFLE POSTS MUST BE 60-IN. TO 96-IN. LONG STEEL POSTS THAT MEET, AT A MINIMUM, THE FOLLOWING PHYSICAL CHARACTERISTICS:
  - COMPOSED OF A HIGH STRENGTH STEEL WITH A MINIMUM YIELD STRENGTH OF 50,000 PSI.
  - INCLUDE A STANDARD "T" SECTION WITH A NOMINAL FACE WIDTH OF 1.38-IN. AND A NOMINAL "T" LENGTH OF 1.48-IN.
  - WEIGH 1.25 POUNDS PER FOOT (± 8%)
- POSTS SHALL BE EQUIPPED WITH PROJECTIONS TO AID IN FASTENING OF BAFFLE MATERIAL.
- INSTALL POSTS TO A MINIMUM OF 24-IN. A MINIMUM HEIGHT OF 1-IN. TO 2-IN. ABOVE THE FABRIC SHALL BE MAINTAINED, AND A MAXIMUM HEIGHT OF 3-FT. SHALL BE MAINTAINED ABOVE THE GROUND.
- POST SPACING SHALL BE AT A MAXIMUM OF 4-FT. ON CENTER.

**BAFFLES - MATERIAL REQUIREMENTS**

- BAFFLE MATERIAL MUST BE COMPOSED OF COIR-BASED MATERIALS OR TURF REINFORCEMENT MATTING (TRM) THAT CONSISTS OF THE FOLLOWING REQUIREMENTS:
  - HAVE A LIGHT PENETRATION (% OPENINGS) BETWEEN 10-35%;
  - FREE OF LOOSE STRAW MATERIAL;
  - HAVE A MINIMUM TENSILE STRENGTH OF 145 LB/FT. AND;
  - HAVE A MINIMUM WIDTH OF 48-IN.
- 12-IN. OF THE FABRIC SHOULD BE PLACED WITHIN EXCAVATED TRENCH AND TOED IN WHEN THE TRENCH IS BACKFILLED OR BAFFLE MATERIAL MAY BE STAPLED INTO GROUND BY USING 12-IN. STAPLES WITH A MAXIMUM SPACING OF 12-IN.
- BAFFLE MATERIAL SHALL BE PURCHASED IN CONTINUOUS ROLLS AND CUT TO THE WIDTH OF THE SEDIMENT BASIN OR TRAP TO AVOID JOINTS.

**BAFFLES - GENERAL NOTES**

- ATTACH BAFFLE TO THE STEEL POSTS USING HEAVY-DUTY PLASTIC TIES THAT ARE EVENLY SPACED ALONG THE ABOVE GROUND PORTION OF EACH POST.
- INSTALL THE BAFFLE ROWS PERPENDICULAR TO THE DIRECTION OF THE STORMWATER FLOW AND PLACE EACH BAFFLE THE PROPER DISTANCE FROM INLET AND OUTLETS TO ALLOW ACCESS FOR MAINTENANCE AND CLEAN-OUT.
- EXTEND BAFFLE TO A MINIMUM OF 3 FEET.

**BAFFLES - INSPECTION & MAINTENANCE**

- THE KEY TO FUNCTIONAL POROUS BAFFLES IS WEEKLY INSPECTION, ROUTINE MAINTENANCE, AND REGULAR SEDIMENT REMOVAL.
- REGULAR INSPECTIONS OF POROUS BAFFLES SHALL BE CONDUCTED ONCE EVERY CALENDAR WEEK AND, AS RECOMMENDED, WITHIN 24-HOURS AFTER EACH RAINFALL EVEN THAT PRODUCES 1/2-IN. OR MORE OF PRECIPITATION.
- ATTENTION TO SEDIMENT ACCUMULATIONS ALONG EACH ROW OF BAFFLES IS EXTREMELY IMPORTANT. ACCUMULATED SEDIMENT SHOULD BE CONTINUALLY MONITORED AND REMOVED WHEN NECESSARY.
- REMOVE ACCUMULATED SEDIMENT WHEN IT REACHES 1/3 THE HEIGHT OF THE BAFFLE ROW OR WHEN IT REACHES THE CLEAN-OUT HEIGHT OF THE SEDIMENT BASIN OR TRAP, WHICHEVER IS REACHED FIRST.
- REMOVED SEDIMENT SHALL BE PLACED IN STOCKPILE STORAGE AREAS OR SPREAD THINLY ACROSS DISTURBED AREA. STABILIZE THE REMOVED SEDIMENT AFTER IT IS RELOCATED.
- CHECK FOR AREAS WHERE STORMWATER RUNOFF HAS ERODED A CHANNEL BENEATH EACH ROW OF BAFFLES, OR WHERE THE BAFFLE HAS SAGGED OR COLLAPSED DUE TO RUNOFF OVERTOPPING THE BAFFLE.
- CHECK FOR TEARS/RIPS WITHIN THE BAFFLES, AREAS WHERE THE BAFFLE HAS BEGUN TO DECOMPOSE, AND FOR ANY OTHER CIRCUMSTANCE THAT MAY RENDER THE BAFFLE INEFFECTIVE. REMOVED DAMAGED BAFFLES AND REINSTALL NEW BAFFLES IMMEDIATELY.
- POROUS BAFFLES SHOULD BE REMOVED WITHIN 30 DAYS AFTER FINAL STABILIZATION IS ACHIEVED AND ONCE IT IS REMOVED, THE RESULTING DISTURBED AREA SHALL BE PERMANENTLY STABILIZED.
- REMOVE ANY ACCUMULATED SEDIMENT UPON BAFFLE REMOVAL. DISPOSE OF SEDIMENT OFF-SITE ACCORDING TO STATE AND LOCAL REGULATIONS.

**8 POROUS BAFFLES**  
SCALE: N.T.S.

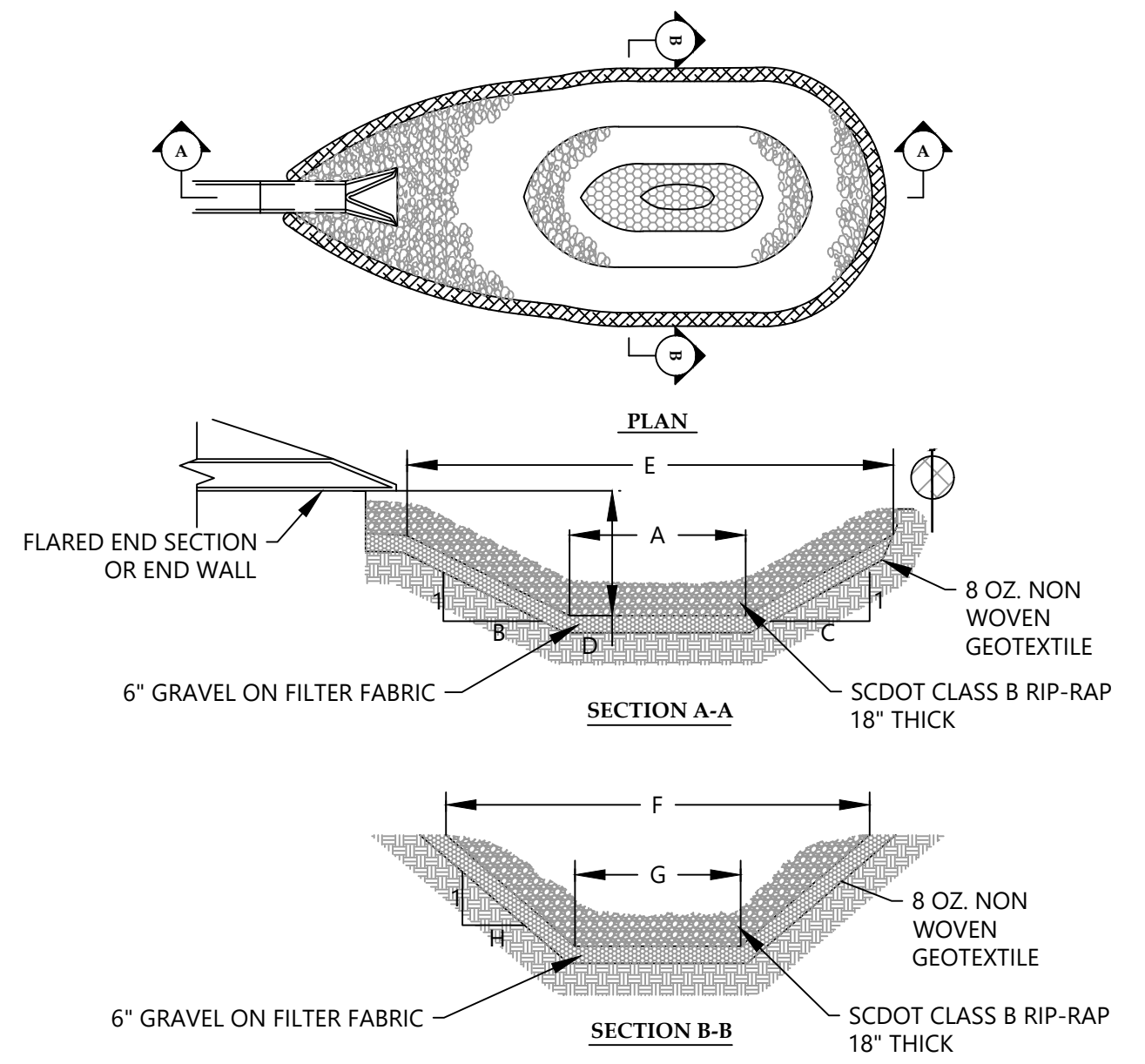

**MAINTENANCE**  
INFLUNGE POOL AT LEAST ONCE PER SEVEN (7) CALENDAR DAYS AND WITHIN 24 HOURS OF A RAIN EVENT GREATER THAN OR EQUAL TO 0.5-INCH IN 24 HOURS. REMOVE SEDIMENT AND RESTORE TO ORIGINAL DIMENSIONS WHEN SEDIMENT ACCUMULATES TO ONE-HALF THE HEIGHT OF THE POOL. CHECK EMBANKMENT, LINING, AND OUTLET AREA FOR ANY DAMAGE AND REPAIR AS NECESSARY, AS SOON AS PRACTICAL.

ID	A	B	C	D	E	F	G	H
PT-SB-1	1.4	3.0	3.0	1.8	12.5	8.8	1.4	2.0
W-SB-1	1.3	3.0	3.0	1.7	11.3	8.0	1.3	2.0
P-SB-1	2.2	3.0	3.0	2.7	18.5	13.0	2.1	2.0
P-SB-2	1.3	3.0	3.0	1.7	11.4	8.0	1.3	2.0
P-SB-3	1.5	3.0	3.0	1.9	12.9	9.0	1.5	2.0
NE-SB-1	1.5	3.0	3.0	1.9	12.7	8.9	1.4	2.0
NE-SB-2	1.2	3.0	3.0	1.5	10.5	7.4	1.2	2.0
NE-SB-3	1.2	3.0	3.0	1.6	10.7	7.5	1.2	2.0
NE-SB-4	1.4	3.0	3.0	1.7	11.8	8.3	1.3	2.0

**9 PLUNGE POOL**  
SCALE: N.T.S.

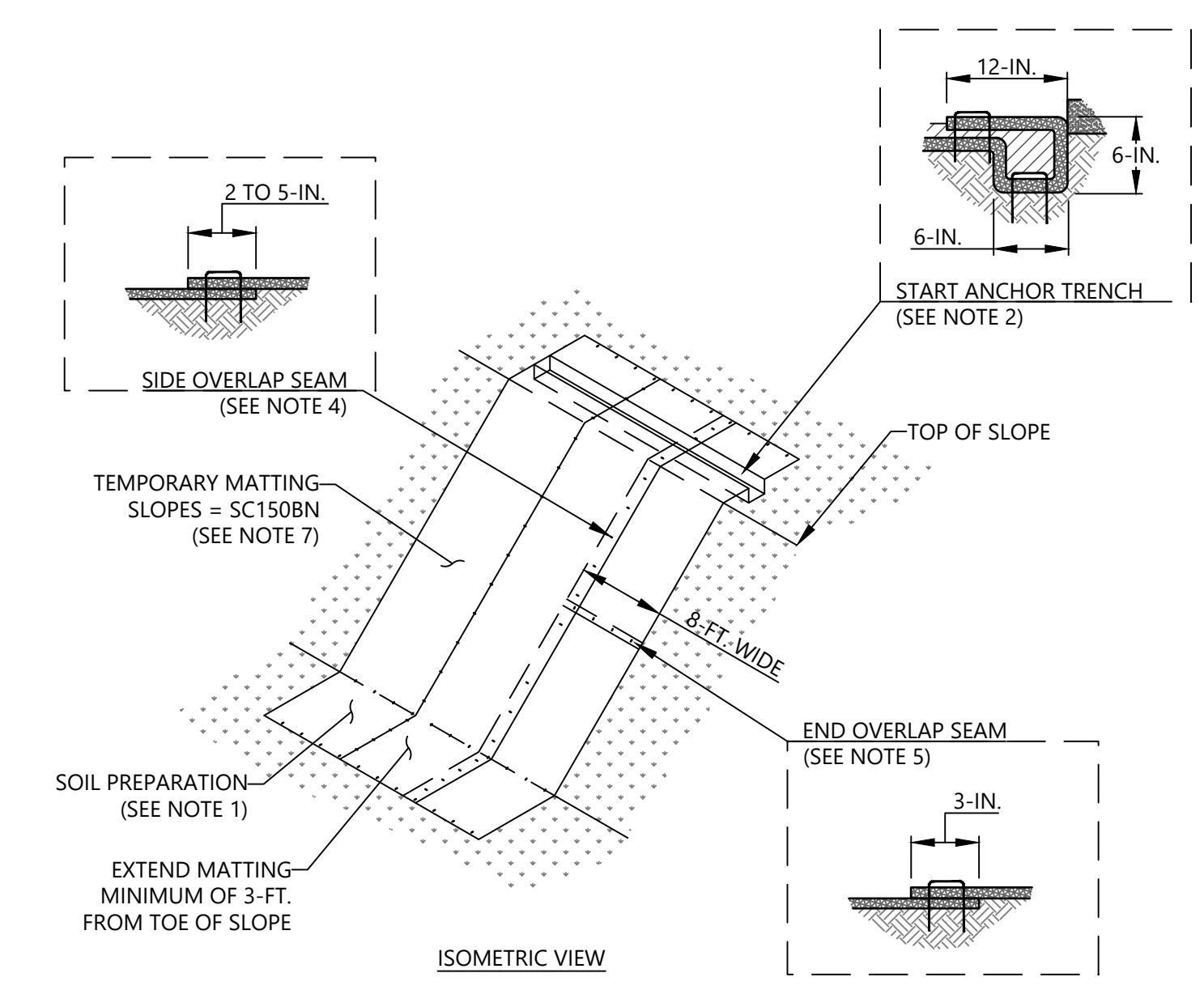

**SLOPE MATTING NOTES**

- PREPARE SOIL BEFORE INSTALLING ROLLED EROSION CONTROL PRODUCTS (RECPs), INCLUDING ANY NECESSARY APPLICATION OF LIME, FERTILIZER, AND SEED.
- BEGIN AT THE TOP OF THE SLOPE BY ANCHORING THE RECPs IN A 6-IN. DEEP X 6-IN. WIDE TRENCH WITH APPROXIMATELY 12-IN. OF RECPs EXTENDED BEYOND THE UP-SLOPE PORTION OF THE TRENCH. ANCHOR THE RECPs WITH A ROW OF STAPLES/STAKES APPROXIMATELY 12-IN. APART IN THE BOTTOM OF THE TRENCH. BACKFILL AND COMPACT THE TRENCH AFTER STAPLING. APPLY SEED TO THE COMPACTED SOIL AND FOLD THE REMAINING 12-IN. PORTION OF RECPs BACK OVER THE SEED AND COMPACTED SOIL. SECURE RECPs OVER COMPACTED SOIL WITH A ROW OF STAPLES/STAKES SPACED APPROXIMATELY 12-IN. APART ACROSS THE WIDTH OF THE RECPs.
- ROLL THE RECPs DOWN OR HORIZONTALLY ACROSS THE SLOPE BASED ON ENVIRONMENT INSPECTOR. RECPs WILL UNROLL WITH APPROPRIATE SIDE AGAINST THE SOIL SURFACE. ALL RECPs MUST BE SECURELY FASTENED TO SOIL SURFACE BY PLACING STAPLES/STAKES IN APPROPRIATE LOCATIONS AS SHOWN IN THE STAPLE PATTERN GUIDE.
- THE EDGES OF PARALLEL RECPs MUST BE STAPLED WITH APPROXIMATELY 2 TO 5-IN. OVERLAP DEPENDING ON THE RECPs TYPE.
- CONSECUTIVE RECPs SPICED DOWN THE SLOPE MUST BE END OVER END (SHINGLE STYLE) WITH AN APPROXIMATE 3-IN. OVERLAP. STAPLE THROUGH OVERLAPPED AREA. APPROXIMATELY 12-IN. APART ACROSS ENTIRE RECPs WIDTH. IN LOOSE SOIL CONDITIONS, THE USE OF STAPLE OR STAKE LENGTHS GREATER THAN 6-IN. MAY BE NECESSARY TO PROPERLY SECURE THE RECPs.
- TEMPORARY MATTING SHALL BE NORTH AMERICAN GREEN BIONET SC150BN OR ENGINEER APPROVED EQUIVALENT.

**SLOPE MATTING MAINTENANCE**

- INSPECT AT LEAST ONCE EVERY CALENDAR WEEK AND WITHIN 24 HOURS OF THE END OF A STORM EVENT OF 0.5-IN. OR GREATER.
- MAKE ANY NECESSARY REPAIRS IMMEDIATELY.
- GOOD CONTACT WITH THE GROUND MUST BE MAINTAINED, AND EROSION MUST NOT OCCUR BENEATH THE RECP.
- ANY AREAS OF THE RECP THAT ARE DAMAGED OR NOT IN CLOSE CONTACT WITH THE GROUND SHALL BE REPAIRED AND STAPLED.
- IF EROSION OCCURS DUE TO POORLY CONTROLLED DRAINAGE, THE PROBLEM SHALL BE FIXED AND THE ERODED AREA PROTECTED.
- MONITOR AND REPAIR THE RECP AS NECESSARY UNTIL GROUND COVER IS ESTABLISHED.

REF: DETAIL BASED ON NCDEQ EROSION AND SEDIMENT CONTROL PLANNING AND DESIGN MANUAL, CHAPTERS 6 AND 8 REVISED, MAY 2013

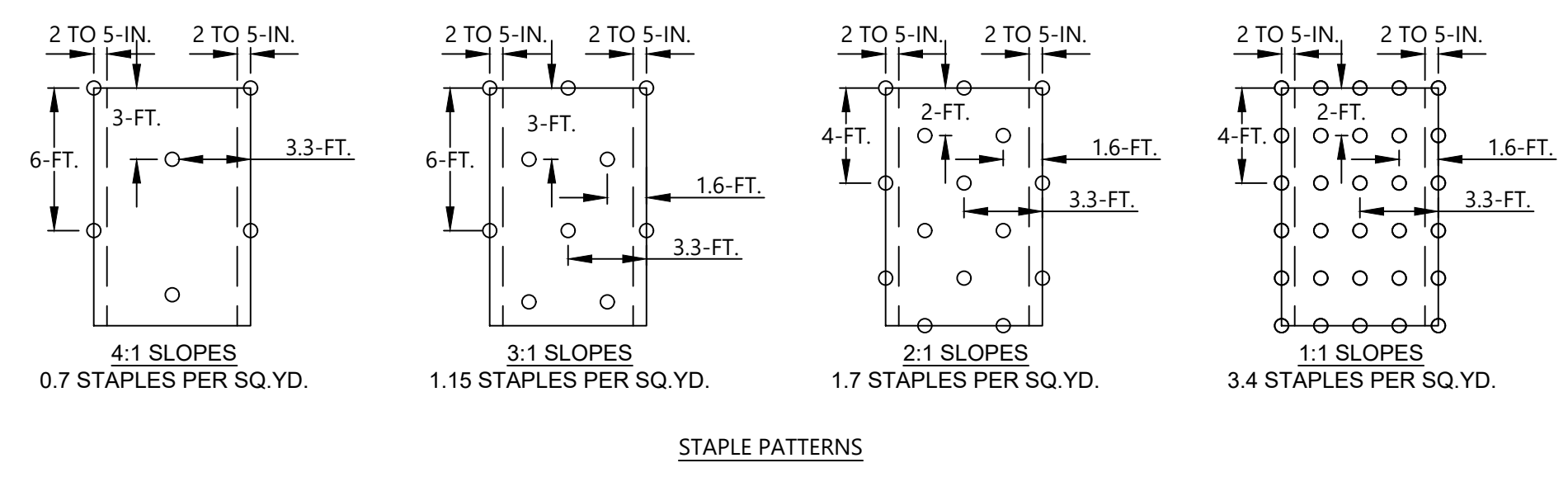

**10 TEMPORARY MATTING SLOPES**  
SCALE: N.T.S.

NO.	DATE	REVISION	INITIAL	PROCESS	PLANT	DESCRIPTION	BY	CHK	CIS	APV
3-22-21										

**DETAILS (SHEET 3 OF 4)**

PROJECT NUMBER: 210730C  
DRAWING NUMBER: 5

FAIRFIELD 1-77 DEVELOPMENT SITE, E&S PLAN - INITIAL PHASE  
LUCK STONE CORPORATION  
FAIRFIELD COUNTY, SOUTH CAROLINA

5 6

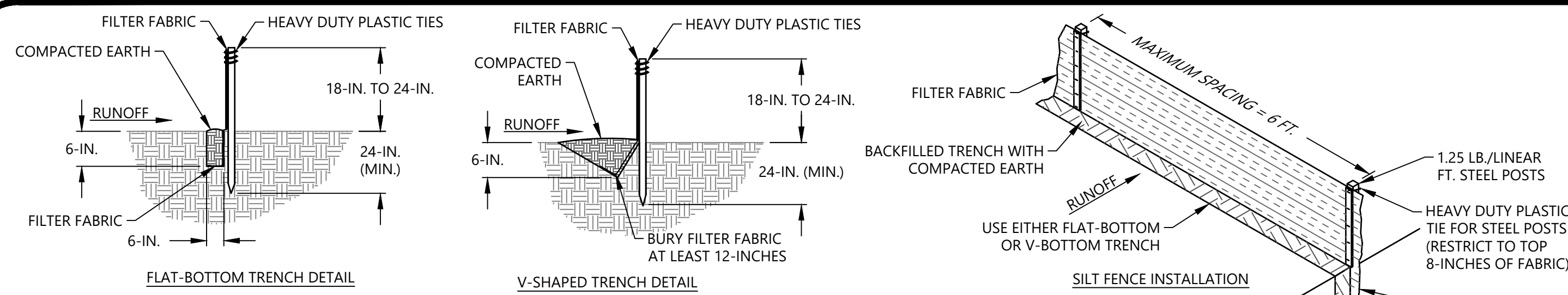

**SILT FENCE NOTES:**

- DO NOT PLACE SILT FENCE ACROSS CHANNELS OR IN OTHER AREAS SUBJECT TO CONCENTRATED FLOWS. SILT FENCE SHOULD NOT BE USED AS A VELOCITY CONTROL BMP. CONCENTRATED FLOWS ARE ANY FLOWS GREATER THAN 0.5 CFS.
- MAXIMUM SHEET OR OVERLAND FLOW PATH LENGTH TO THE SILT FENCE SHALL BE 100- FEET.
- MAXIMUM SLOPE STEEPNESS (NORMAL [PERPENDICULAR] TO THE FENCE LINE) SHALL BE 2:1.
- SILT FENCE JOINTS, WHEN NECESSARY, SHALL BE COMPLETED BY ONE OF THE FOLLOWING OPTIONS:
  - WRAP EACH FABRIC TOGETHER AT A SUPPORT POST WITH BOTH ENDS FASTENED TO THE POST, WITH A 1-FOOT MINIMUM OVERLAP;
  - OVERLAP SILT FENCE BY INSTALLING 3- FEET PAST THE SUPPORT POST TO WHICH THE NEW SILT FENCE ROLL IS ATTACHED. ATTACH OLD ROLL TO NEW ROLL WITH HEAVY-DUTY PLASTIC TIES; OR,
  - OVERLAP ENTIRE WIDTH OF EACH SILT FENCE ROLL FROM ONE SUPPORT POST TO THE NEXT SUPPORT POST.
- ATTACH FILTER FABRIC TO THE STEEL POSTS USING HEAVY-DUTY PLASTIC TIES THAT ARE EVENLY SPACED WITHIN THE TOP 8-INCHES OF THE FABRIC.
- INSTALL THE SILT FENCE PERPENDICULAR TO THE DIRECTION OF THE STORMWATER FLOW AND PLACE THE SILT FENCE THE PROPER DISTANCE FROM THE TOE OF STEEP SLOPES TO PROVIDE SEDIMENT STORAGE AND ACCESS FOR MAINTENANCE AND CLEANOUT.
- INSTALL SILT FENCE CHECKS (TIE-BACKS) EVERY 50-100 FEET, DEPENDENT ON SLOPE, ALONG SILT FENCE THAT IS INSTALLED WITH SLOPE AND WHERE CONCENTRATED FLOWS ARE EXPECTED OR ARE DOCUMENTED ALONG THE PROPOSED/INSTALLED SILT FENCE.

**SILT FENCE POST REQUIREMENTS:**

- SILT FENCE POSTS MUST BE 48-INCH LONG STEEL POSTS THAT MEET, AT A MINIMUM, THE FOLLOWING PHYSICAL CHARACTERISTICS:
  - COMPOSED OF A HIGH STRENGTH STEEL WITH A MINIMUM YIELD STRENGTH OF 50,000 PSI.
  - INCLUDE A STANDARD "T" SECTION WITH A NOMINAL FACE WIDTH OF 1.38-INCHES AND A NOMINAL "I" LENGTH OF 1.48-INCHES.
  - WEIGH 1.25 POUNDS PER FOOT (± 8%)
- POSTS SHALL BE EQUIPPED WITH PROJECTIONS TO AID IN FASTENING OF FILTER FABRIC.
- STEEL POSTS MAY NEED TO HAVE A METAL SOIL STABILIZATION PLATE WELDED NEAR THE BOTTOM WHEN INSTALLED ALONG STEEP SLOPES OR INSTALLED IN LOOSE SOILS. THE PLATE SHOULD HAVE A MINIMUM CROSS SECTION OF 17-SQUARE INCHES AND BE COMPOSED OF 15 GAUGE STEEL, AT A MINIMUM. THE METAL SOIL STABILIZATION PLATE SHOULD BE COMPLETELY BURIED.
- INSTALL POSTS TO A MINIMUM OF 24-INCHES. A MINIMUM HEIGHT OF 1 TO 2-INCHES ABOVE THE FABRIC SHALL BE MAINTAINED, AND A MAXIMUM HEIGHT OF 3 FEET SHALL BE MAINTAINED ABOVE THE GROUND.
- POST SPACING SHALL BE AT A MAXIMUM OF 6- FEET ON CENTER.

**SILT FENCE FABRIC REQUIREMENTS:**

- SILT FENCE MUST BE COMPOSED OF WOVEN GEOTEXTILE FILTER FABRIC THAT CONSISTS OF THE FOLLOWING REQUIREMENTS:
  - COMPOSED OF FIBERS CONSISTING OF LONG CHAIN SYNTHETIC POLYMERS OF AT LEAST 85% BY WEIGHT OF POLYOLEFINS, POLYESTERS, OR POLYAMIDES THAT ARE FORMED INTO A NETWORK SUCH THAT THE FILAMENTS OR YARNS RETAIN DIMENSIONAL STABILITY RELATIVE TO EACH OTHER;
  - FREE OF ANY TREATMENT OR COATING WHICH MIGHT ADVERSELY ALTER ITS PHYSICAL PROPERTIES AFTER INSTALLATION;
  - FREE OF ANY DEFECTS OR FLAWS THAT SIGNIFICANTLY AFFECT ITS PHYSICAL AND/OR FILTERING PROPERTIES; AND,
  - HAVE A MINIMUM WIDTH OF 36-INCHES.
- USE ONLY FABRIC APPEARING ON SC DOT'S QUALIFIED PRODUCTS LISTING (QPL), APPROVAL SHEET #34, MEETING THE REQUIREMENTS OF THE MOST CURRENT EDITION OF THE SC DOT STANDARD SPECIFICATIONS FOR HIGHWAY CONSTRUCTION.
- 12-INCHES OF THE FABRIC SHOULD BE PLACED WITHIN EXCAVATED TRENCH AND SECURED WHEN THE TRENCH IS BACKFILLED.
- FILTER FABRIC SHALL BE PURCHASED IN CONTINUOUS ROLLS AND CUT TO THE LENGTH OF THE BARRIER TO AVOID JOINTS.
- FILTER FABRIC SHALL BE INSTALLED AT A MINIMUM OF 24-INCHES ABOVE THE GROUND.

**SILT FENCE INSPECTION & MAINTENANCE:**

- THE KEY TO FUNCTIONAL SILT FENCE IS WEEKLY INSPECTIONS, ROUTINE MAINTENANCE, AND REGULAR SEDIMENT REMOVAL.
- REGULAR INSPECTIONS OF SILT FENCE SHALL BE CONDUCTED ONCE EVERY CALENDAR WEEK AND, AS RECOMMENDED, WITHIN 24-HOURS AFTER EACH RAINFALL EVENT THAT PRODUCES 1/2-INCH OR MORE OF PRECIPITATION.
- ATTENTION TO SEDIMENT ACCUMULATIONS ALONG THE SILT FENCE IS EXTREMELY IMPORTANT. ACCUMULATED SEDIMENT SHOULD BE CONTINUALLY MONITORED AND REMOVED WHEN NECESSARY.
- REMOVE ACCUMULATED SEDIMENT WHEN IT REACHES 1/3 THE HEIGHT OF THE SILT FENCE.
- REMOVED SEDIMENT SHALL BE PLACED IN STOCKPILE STORAGE AREAS OR SPREAD THINLY ACROSS DISTURBED AREA. STABILIZE THE REMOVED SEDIMENT AFTER IT IS RELOCATED.
- CHECK FOR AREAS WHERE STORMWATER RUNOFF HAS ERODED A CHANNEL BENEATH THE SILT FENCE, OR WHERE THE FENCE HAS SAGGED OR COLLAPSED DUE TO RUNOFF OVERTOPPING THE SILT FENCE. INSTALL CHECKS/TIE-BACKS AND/OR REINSTALL SILT FENCE, AS NECESSARY.
- CHECK FOR TEARS WITHIN THE SILT FENCE, AREAS WHERE SILT FENCE HAS BEGUN TO DECOMPOSE, AND FOR ANY OTHER CIRCUMSTANCE THAT MAY RENDER THE SILT FENCE INEFFECTIVE. REMOVE DAMAGED SILT FENCE AND REINSTALL NEW SILT FENCE IMMEDIATELY.
- SILT FENCE SHOULD BE REMOVED WITHIN 30 DAYS AFTER FINAL STABILIZATION IS ACHIEVED AND ONCE IT IS REMOVED, THE RESULTING DISTURBED AREA SHALL BE PERMANENTLY STABILIZED.

**11**  
**6** SILT FENCE  
SCALE: N.T.S.

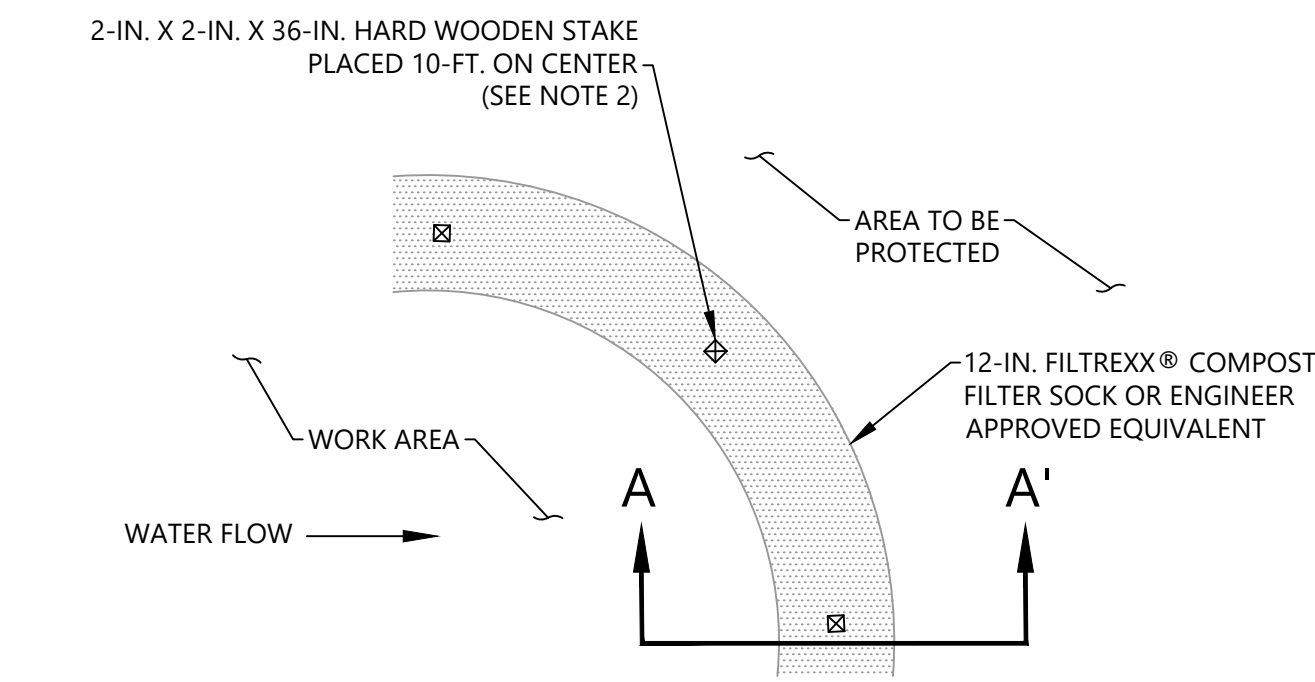

PLAN-VIEW

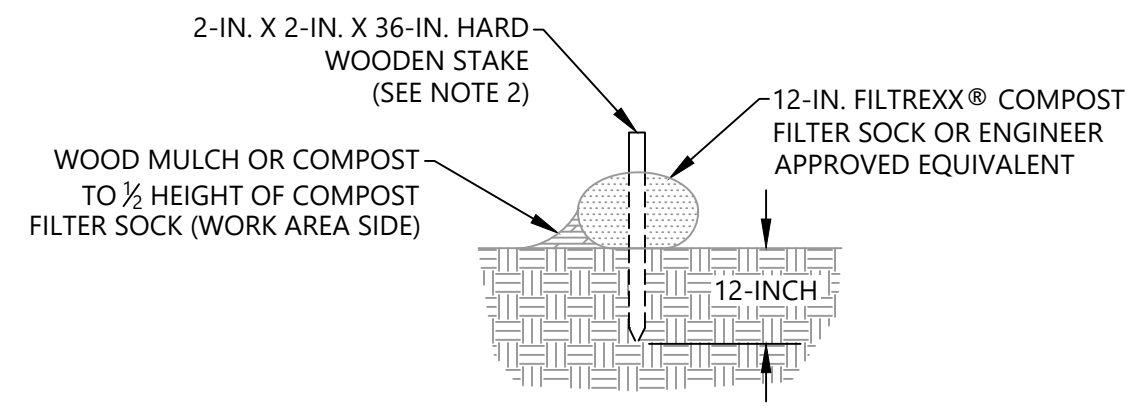

SECTION A-A'

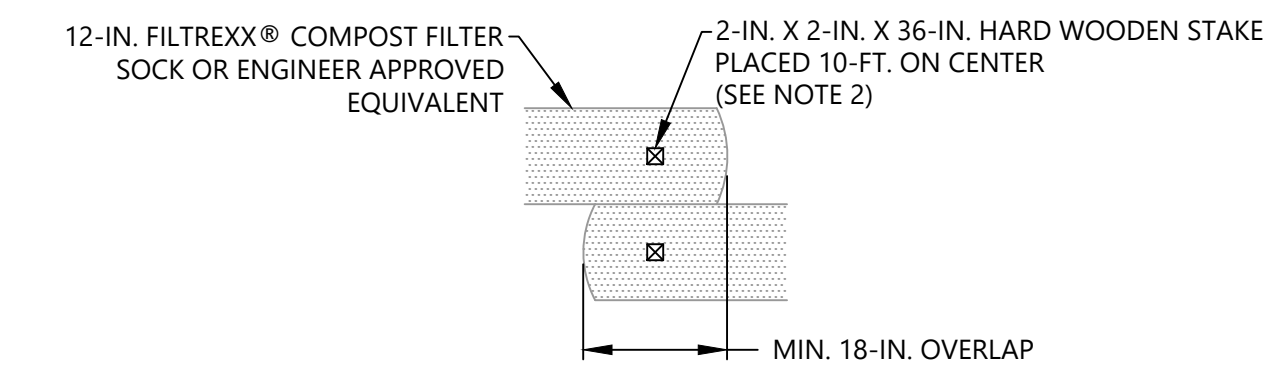

CONNECTION DETAIL

**COMPOST FILTER SOCK NOTES:**

- USE 12-INCH FILTREXX® COMPOST FILTER SOCK OR ENGINEER APPROVED EQUIVALENT.
- HARD WOODEN STAKES SHALL BE INSTALLED THROUGH THE MIDDLE OF THE COMPOST FILTER SOCK. SPACE STAKES EVERY 10 LINEAR FEET. DRIVE THE STAKE TO A MINIMUM OF 1- FT. INTO THE GROUND LEAVING A MINIMUM OF 3-IN. PROTRUDING ABOVE THE COMPOST FILTER SOCK.
- WHEN MULTIPLE COMPOST FILTER SOCKS ARE USED, INSTALL MINIMUM OF 18-IN. OVERLAP. WHEN INSTALLING, USE 2-IN. BY 2-IN. BY 3- FT. WOODEN STAKES TO HOLD COMPOST FILTER SOCKS IN PLACE.
- TO PREVENT WATER & SEDIMENT FROM FLOWING AROUND MEASURES A MINIMUM 10- FT. LENGTH OF COMPOST FILTER SOCK MUST BE PLACED UPSLOPE AT A 30 DEGREE ANGLE FROM THE ENDS OF THE MEASURES.
- SEDIMENT CONTROL SHOULD BE INSTALLED PARALLEL TO THE BASE OF THE SLOPE OR OTHER DISTURBED AREA. IN CHALLENGING CONDITIONS (I.E., 2:1 SLOPES), A SECOND SEDIMENT CONTROL SHALL BE CONSTRUCTED AT THE TOP OF THE SLOPE.
- LOOSE COMPOST MAY BE BACKFILLED ALONG THE UPSLOPE SIDE OF THE SEDIMENT CONTROL, FILLING THE SEAM BETWEEN THE SOIL SURFACE AND DEVICE, IMPROVING FILTRATION AND SEDIMENT RETENTION.

**COMPOST FILTER SOCK MAINTENANCE:**

- REGULAR INSPECTIONS OF COMPOST FILTER SOCKS SHALL BE CONDUCTED ONCE EVERY CALENDAR WEEK AND, AS RECOMMENDED, WITHIN 24-HOURS AFTER EACH RAINFALL EVENT THAT PRODUCES 1/2-IN. OR MORE OF PRECIPITATION.
- MAKE ANY NECESSARY REPAIRS IMMEDIATELY.
- REMOVE ACCUMULATED SEDIMENT OVER 1/2 THE HEIGHT OF THE COMPOST FILTER SOCK AND ANY DEBRIS. THE COMPOST SOCK MUST BE REPLACED IF CLOGGED OR TORN.
- IF PONDING BECOMES EXCESSIVE, THE SOCK MAY NEED TO BE REPLACED WITH A LARGER DIAMETER OR A DIFFERENT MEASURE. THE SOCK NEEDS TO BE REINSTALLED IF UNDERMINED OR DISLODGED.
- THE COMPOST SOCK SHALL BE INSPECTED UNTIL LAND DISTURBANCE IS COMPLETE AND THE AREA ABOVE THE MEASURE HAS BEEN PERMANENTLY STABILIZED.
- SHOULD THE SILT FENCE ADJACENT TO THE OUTLET COLLAPSE, TEAR, OR BECOME INEFFECTIVE, REPAIR OR REPLACE IT PROMPTLY.
- REMOVE ALL COMPOST FILTER SOCK MATERIALS AND UNSTABLE SEDIMENT DEPOSITS AND BRING THE AREA TO GRADE AND STABILIZE IT AFTER THE CONTRIBUTING DRAINAGE AREA HAS BEEN PROPERLY STABILIZED.

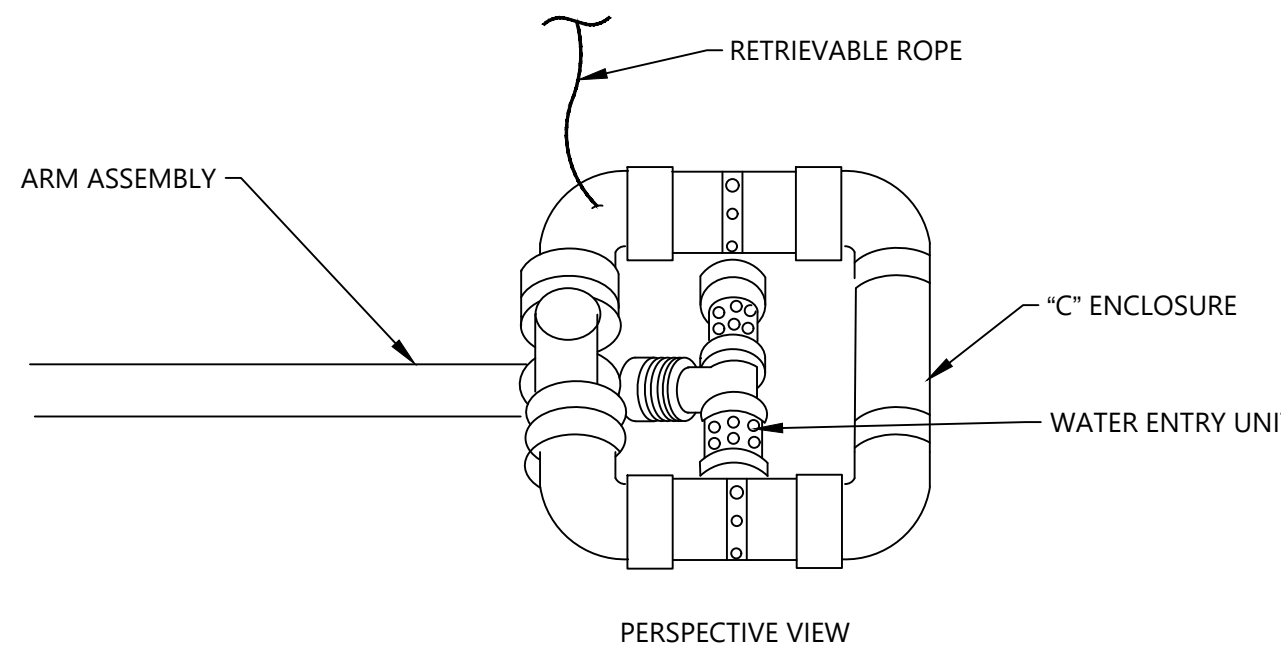
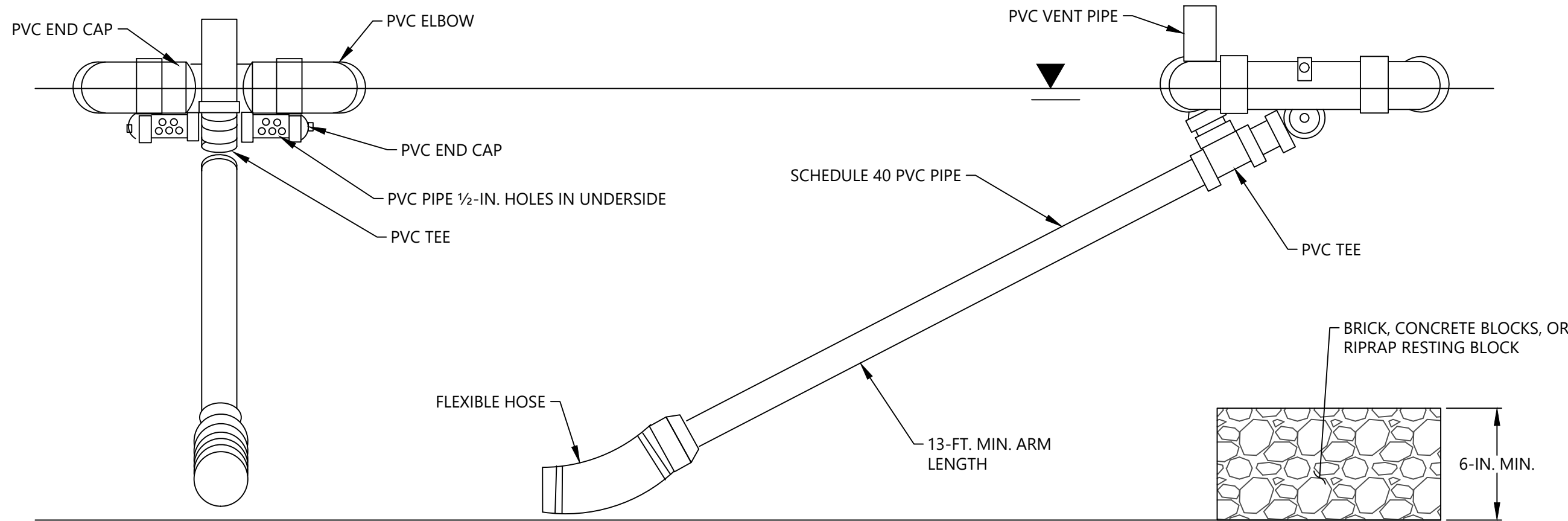

**MAINTENANCE NOTES:**

- INSPECT SKIMMER AT LEAST ONCE PER SEVEN (7) CALENDAR DAYS AND WITHIN 24 HOURS OF A RAIN EVENT GREATER THAN OR EQUAL TO 0.5-IN. IN 24 HOURS.

SKIMMER TABLE			
SEDIMENT BASIN	PURPOSE	SIZE (IN.)	ORIFICE SIZE (IN.)
PT-SB-1	E&SC DEWATERING	8"	8"
W-SB-1	E&SC DEWATERING	8"	7"
P-SB-1	E&SC DEWATERING	8"	8"
P-SB-2	E&SC DEWATERING	8"	7"
P-SB-3	E&SC DEWATERING	8"	8"
NE-SB-1	E&SC DEWATERING	8"	8"
NE-SB-2	E&SC DEWATERING	6"	6"
NE-SB-3	E&SC DEWATERING	8"	6"
NE-SB-4	E&SC DEWATERING	8"	8"

**12**  
**6** SKIMMER  
SCALE: N.T.S.

**13**  
**6** COMPOST FILTER SOCK  
SCALE: N.T.S.



9751 SOUTHERN PINE BLVD  
CHARLOTTE, NC 28273  
(704) 523-4726

ENGINEERING FIRM  
LICENSE NUMBER: F-0176

NO.	DATE	BY	CHK	CIS	APV
3-22-21					

PROJECT NUMBER  
**210730C**  
DRAWING NUMBER

REVISIONS  
REVISED INITIAL PROCESS PLANT DESCRIPTION

FAIRFIELD 1-77 DEVELOPMENT SITE, E&SC PLAN - INITIAL PHASE  
LUCK STONE CORPORATION  
FAIRFIELD COUNTY, SOUTH CAROLINA

**6** **6**

## **Appendix II – Sediment Basin Calculations**



Comprehensive Stormwater Pollution Prevention Plan (C-SWPPP)  
Luck Stone Corporation | Fairfield Quarry – Initial Phase  
Sediment Basin and Plunge Pool Calculation  
S&ME Project No. 210730C

COMPUTATIONS BY: Signature Justin C. Condon Date 3/19/2021  
Name Justin C. Condon  
Title Staff Professional

ASSUMPTIONS Signature Andrew E. Wilmer Date 3/19/2021  
AND PROCEDURES Name Andrew E. Wilmer, E.I.  
CHECKED BY: Title Staff Professional

COMPUTATIONS Signature Matthew H. Kunkle Date 3/19/2021  
CHECKED BY: Name Matthew H. Kunkle, P.E.  
Title Project Engineer

REVIEWED BY: Signature \_\_\_\_\_ Date 3/19/2021  
Name Christopher J.L. Stahl, P.E.  
Title Principal Engineer

REVIEW NOTES / COMMENTS: \_\_\_\_\_  
\_\_\_\_\_  
\_\_\_\_\_



## ❖ OBJECTIVE

This Sediment Basin Calculation package (package) was developed to evaluate the hydrologic and hydraulic characteristics of proposed development areas at the Luck Stone Corporation – Fairfield I-77 Quarry (Site) to design proposed sediment basins intended to manage stormwater and sediment. Each sediment basin at the Site was designed in accordance with the design criteria presented in the South Carolina Department of Health and Environmental Control (SC DHEC) Stormwater Best Management Practice (BMP) Handbook. Meanwhile, plunge pools at each sediment basin outlet were designed based on guidance provided by the Natural Resources Conservation Service (NRCS) guidance to dissipate flows and resist erosion from each sediment basin.

## ❖ SUMMARY

Site development activities were anticipated to disturb large surface areas; as such, sediment basins were designed to manage sediment and peak stormwater flows during anticipated construction conditions for the 10-year (yr), 25-yr, and 100-yr, 24-hour (hr) storm events. Proposed sediment basins were designed in general accordance with the SC DHEC Stormwater BMP Handbook and the selected design criteria were summarized subsequently within this package. Plunge pools were designed to dissipate flows from each sediment basin and each plunge pool was designed in accordance with the NRCS “Riprap Lined Plunge Pool for Cantilever Outlet” spreadsheet, which was developed by the United States Department of Agriculture (USDA) Soil Conservation Service (SCS) as described within Design Note No. 6.

## ❖ REFERENCES

The following references were utilized during the development of this calculation package.

1. *NOAA Atlas 14, Volume 2, Version 3*, Bonnin, G.M., Martin, D., Lin, B., Parzybok, T., Yekta, M., & Riley, D., April 21, 2017.
2. TR-55 Urban Hydrology for Small Watersheds, USDA-NRCS, June 1986.
3. *NRCS Soil Figures*, S&ME Inc., February 2021.
4. *Drainage Area Figures*, S&ME Inc., March 2021.
5. *Compiled HydroCAD Report*, S&ME Inc., March 2021.
6. *Compiled SEDIMOT IV Report*, S&ME Inc., March 2021.
7. SC DHEC Stormwater BMP Handbook, Sediment Control BMPs – Sediment Basins, SC DHEC, Revised March 2014.
8. Design Hydrology and Sedimentology for Small Catchments, Haan, C.T., Barfield, and Hayes, 1994. Pg. 147-148.
9. Determining the Skimmer Size and the Required Orifice, Faircloth Skimmer, November 2007.
10. SC DHEC Stormwater BMP Handbook, Appendix E – South Carolina Soils, SC DHEC, Revised July 2005.
11. SC DHEC Stormwater BMP Handbook, Appendix K – Figures, SC DHEC, Revised July 2005.
12. ENG – Riprap Lined Plunge Pool for Cantilever Outlet, USDA SCS Design Note. No. 6, 2<sup>nd</sup> Ed. March 5, 1986.
13. Riprap Lined Plunge Pool for Cantilever Outlet, NRCS Plunge Pool Sheets, March 2021.



## ❖ DEFINITION OF VARIABLES

The following variables are defined or used as a part of this calculation package.

Q = flow rate (cfs)	$\gamma_c$ = unit weight of concrete (lb/ft <sup>3</sup> )
CN = curve number (unitless)	$\gamma_w$ = unit weight of water (lb/ft <sup>3</sup> )
i = rainfall intensity (in./hr)	U <sub>riser</sub> = uplift force acting on riser (lbs)
A = drainage area (acres)	H = height of spillway or riser (ft)
T <sub>c</sub> = time of concentration (min)	A <sub>r</sub> = area of riser (ft <sup>2</sup> )
T <sub>x</sub> = T <sub>c</sub> component number (min)	A <sub>o</sub> = skimmer orifice area (ft <sup>2</sup> )
L = spillway length, length of pipe (ft)	V <sub>req</sub> = required sediment storage volume (ft <sup>3</sup> )
a = cross-sectional area of the pipe (ft <sup>2</sup> )	K <sub>v</sub> = velocity factor (ft/sec)
g = gravity (ft/s <sup>2</sup> )	P <sub>2</sub> = 2-year, 24-hour rainfall (in.)
W <sub>AB</sub> = weight of anti-flotation block (lbs)	P = rainfall intensity (in.)
L <sub>AB</sub> = length of anti-flotation block (ft)	n = Manning's roughness coefficient (unitless)
H <sub>AB</sub> = height of anti-flotation block (ft)	v = velocity (ft/s)
R = hydraulic radius (ft)	D <sub>o</sub> = outlet pipe diameter (ft)
d = depth (ft) or orifice diameter (in.)	d <sub>50</sub> = riprap size (ft)
S = max. retention after rainfall begins (in.)	s = slope (ft/ft)
K <sub>e</sub> = entrance head loss coefficient (unitless)	K <sub>c</sub> = frictional head loss coefficient (unitless)
K <sub>b</sub> = bend head loss coefficient (unitless)	

## ❖ KNOWN AND ASSUMED VARIABLES

g = 32.2 ft/s <sup>2</sup>	[assumed]
P <sub>2</sub> = 3.54 in., P <sub>10</sub> = 5.14 in., P <sub>25</sub> = 6.22 in., P <sub>100</sub> = 8.09 in.	[Reference 1]
y <sub>w</sub> = 62.4 lb/ft <sup>3</sup>	[assumed]
y <sub>c</sub> = 150 lb/ft <sup>3</sup>	[assumed]

## ❖ DESIGN CRITERIA

Each sediment basin was designed in accordance with the SC DHEC Stormwater BMP Handbook with the following criteria:

- ◆ Total Suspended Solids (TSS) removal efficiency is greater than or equal to 80% or peak settleable solids concentration is less than 0.5 milliliters per liter;
- ◆ Maximum drainage area is limited to 30 acres unless alternate sediment capture methodology is utilized (i.e., SEDIMOT IV software);
- ◆ Principal spillway discharge capacity developed for the 10-yr, 24-hr storm event;
- ◆ Emergency spillway capacity developed for the 100-yr, 24-hour storm event;
- ◆ Top of embankment elevation crest selected to be at least 2 ft height above the principal spillway crest and 1 ft above the emergency spillway crest;
- ◆ Maintain 0.5 ft of freeboard within the emergency spillway during 100-yr storm;



- ◆ Minimum sediment storage capacity of 3,600 cubic feet (ft<sup>3</sup>) per drainage area acre;
- ◆ Dewatering time is maintained between 48 and 120 hours;
- ◆ Sediment basin designed with a bottom slope of at least 0.5%;
- ◆ Sediment basin length is at least two times the basin width;
- ◆ Sediment basin side slopes are constructed at 2 horizontal to 1 vertical (2H:1V) or flatter;
- ◆ 20 percent of the basin volume is maintained within the basin forebay; and
- ◆ Basin maintains a geometry that is accessible by maintenance equipment.





## ❖ 1.0 SEDIMENT BASIN DESIGN CALCULATIONS

### 1.1 Compute flow into point of interest for 10-yr, 25-yr, and 100-yr, 24-hr design storms

Each sediment basin was located based on existing topographic features and the proposed Site development plan for the facility. Drainage areas that contribute stormwater runoff to each proposed sediment basin were delineated considering development or construction conditions during initial site clearing. From the existing and proposed drainage features on site, a point of interest (POI) was selected at the inlet to each proposed sediment basin. A point of interest was considered to be the analysis point of a contributing watershed or group of sub-catchments to which the disturbed areas route stormwater. **Reference 4** presents the proposed sediment basin locations and the contributing drainage areas.

Runoff volumes for the 10-yr, 24-hr and 100-yr, 24-hr design storms were calculated using the Soil Conservation Service (SCS) Curve Number (CN) Method, presented as follows:

$$Q = \frac{(P-0.2S)^2}{(P+0.8S)} \quad S = \frac{1000}{CN} \quad \text{[Reference 2]}$$

The curve number “CN” is an empirical parameter used to predict direct runoff (Q, in inches) from rainfall of a drainage area and was developed based on the surface cover type of a drainage area. Drainage areas at the Site consisted of multiple soil and cover types. NRCS Web Soil Survey (**Reference 3**) was queried to identify the hydrologic soil groups on site and the preliminary site development plan was referenced to select cover types during construction conditions. As summarized in **Table 1** shown below, S&ME assumed that each drainage area consisted entirely of bare soil during construction conditions and curve numbers were selected accordingly.

Drainage Area	Total Area		Combined Curve Number
	(sq.ft.)	(acres)	
PT-SB-1	1,012,355	23.2	94
W-SB-1	599,872	13.8	94
P-SB-1	1,936,998	44.5	94
P-SB-2	603,049	13.8	94
P-SB-3	884,859	20.3	94
NE-SB-1	906,076	20.8	94
NE-SB-2	334,011	7.7	94
NE-SB-3	441,198	10.1	94
NE-SB-4	679,173	15.6	94



The time of concentration ( $T_c$ ) is the time for stormwater flow to travel from the most hydrologically remote point in a drainage area to leave the watershed or to reach the point of interest. The time of concentration was estimated using the Technical Release 55 (TR-55) method (**Reference 2**). TR-55 provides guidance to compute the  $T_c$  for sheet flow, shallow concentrated flow, and open channel flow components of a drainage area or watershed. The first component of stormwater runoff is sheet flow, which can be estimated by the following equation for drainage lengths less than or equal to 300 ft:

$$T_t = \frac{0.007(nL)^{0.8}}{(P_2)^{0.5} s^{0.4}} \quad \text{[Reference 2]}$$

The estimated sheet flow travel time to each basin was calculated, as shown in **Table 2** below:

Table 2: Drainage Area Sheet Flow Summary					
Location ID	Manning's Roughness Coefficient {n}	Length {L} (ft)	Slope {s} (ft/ft)	2-Yr, 24-Hr Rainfall (in) [Ref. 1]	Travel Time {T <sub>t</sub> } (min)
PT-SB-1	0.050	300	0.0546	3.54	6.2
W-SB-1	0.050	300	0.0707	3.54	5.6
P-SB-1	0.050	300	0.0838	3.54	5.3
P-SB-2	0.050	300	0.0842	3.54	5.2
P-SB-3	0.050	300	0.1095	3.54	4.7
NE-SB-1	0.050	300	0.0464	3.54	6.7
NE-SB-2	0.050	300	0.0812	3.54	5.3
NE-SB-3	0.050	300	0.1075	3.54	4.8
NE-SB-4	0.050	300	0.0719	3.54	5.6



The second component of the estimated time of concentration for each drainage area was shallow concentrated flow. Shallow concentrated flow was computed using the following equations:

$$V_{unpaved} = K_v * (s)^{0.5} \quad \text{[Reference 2]}$$

$$T_i = \frac{L}{V * 60} \text{ (min)} \quad \text{[Reference 2]}$$

For disturbed/construction conditions, the ground surface condition of “Nearly Bare and Untilled” was considered and a  $K_v$  of 10 ft/sec was selected. The estimated shallow concentrated flow travel time to each sediment basin was calculated, as shown in **Table 3** below.

Table 3: Drainage Area Shallow Concentrated Flow Summary					
Location ID	Surface Description	Length {L} (ft)	Slope {s} (ft/ft)	Average Velocity {V} (ft/s)	Travel Time {T <sub>i</sub> } (min)
PT-SB-1	Nearly Bare & Untilled	804	0.0630	2.5	5.3
W-SB-1	Nearly Bare & Untilled	334	0.1196	3.5	1.6
P-SB-1	Nearly Bare & Untilled	1294	0.0737	2.7	7.9
P-SB-2	Nearly Bare & Untilled	582	0.1023	3.2	3.0
P-SB-3	Nearly Bare & Untilled	699	0.0738	2.7	4.3
NE-SB-1	Nearly Bare & Untilled	690	0.1262	3.6	3.2
NE-SB-2	Nearly Bare & Untilled	340	0.2754	5.2	1.1
NE-SB-3	Nearly Bare & Untilled	540	0.1570	4.0	2.3
NE-SB-4	Nearly Bare & Untilled	290	0.0706	2.7	1.8



Once the stormwater runoff reaches a channel, swale or ditch, the estimated flow velocity to each sedimentation basin was calculated by Manning’s equation and utilized to compute flow velocity and subsequently the time of concentration.

$$V = \frac{1.49(R^{\frac{2}{3}} \times s^{\frac{1}{2}})}{n} \quad \text{[Reference 2]}$$

**Table 4**, below, summarizes the open channel flow calculations.

Table 4: Drainage Area Open Channel Flow Summary				
Location ID	Slope {s} (ft/ft)	Manning's Roughness Coefficient {n}	Length {L} (ft)	Travel Time {T <sub>B</sub> } (min)
PT-SB-1	-	-	-	-
W-SB-1	0.0190	0.022	559	0.7
P-SB-1	0.0045	0.022	341	0.9
P-SB-2	0.0240	0.022	300	0.3
P-SB-3	0.0088	0.022	113	0.2
NE-SB-1	-	-	-	-
NE-SB-2	-	-	-	-
NE-SB-3	-	-	-	-
NE-SB-4	0.0328	0.022	1188	1.1



The total time of concentration is computed by summing each travel time component of a drainage area and the results are summarized in **Table 5** below.

Table 5: Estimated Time of Concentration Summary					
Location ID	Sheet Flow Travel Time (min) [Ref.2]	Shallow Concentrated Flow Travel Time (min) [Ref.2]	Channel Flow Travel Time (min) [Ref.2]	Pipe Flow Travel Time (min)	Time of Concentration (min) [Ref.2]
PT-SB-1	6.2	5.3	-	-	11.5
W-SB-1	5.6	1.6	0.7	-	7.9
P-SB-1	5.3	7.9	0.9	-	14.1
P-SB-2	5.2	3.0	0.3	-	8.5
P-SB-3	4.7	4.3	0.2	-	9.2
NE-SB-1	6.7	3.2	-	-	9.9
NE-SB-2	5.3	1.1	-	-	6.4
NE-SB-3	4.8	2.3	-	-	7.1
NE-SB-4	5.6	1.8	1.1	-	8.5



Runoff peak flow rates were computed for the 10-yr, 25-yr, and 100-yr design storms for initial construction conditions and a Type II rainfall distribution using HydroCAD®, the output file is provided as **Attachment I. Table 6** summarizes each of the flow rates for each design storm below.

Sediment Basin ID	Drainage Area {A} (acres)	Curve Number {CN}	Time of Concentration {T <sub>c</sub> }	10-Year Storm Runoff {Q <sub>10</sub> } (cfs)	25-Year Storm Runoff {Q <sub>25</sub> } (cfs)	100-Year Storm Runoff {Q <sub>100</sub> } (cfs)
PT-SB-1	23.2	94.0	11.5	135.91	166.47	218.38
W-SB-1	13.8	94.0	7.9	90.38	110.63	145.49
P-SB-1	44.5	94.0	14.1	241.19	295.54	389.04
P-SB-2	13.8	94.0	8.5	89.23	109.25	143.69
P-SB-3	20.3	94.0	9.2	127.96	156.69	206.12
NE-SB-1	20.8	94.0	9.9	127.97	156.73	206.20
NE-SB-2	7.7	94.0	6.4	51.88	63.51	83.52
NE-SB-3	10.1	94.0	7.1	67.89	83.09	109.26
NE-SB-4	15.6	94.0	8.5	100.49	123.04	161.83

### 1.2 Confirm basin length-to-width ratio

As stated within the Design Criteria section, SC DHEC requires that sediment basins be designed with a minimum length-to-width ratio of 2:1 (**Reference 7**). As shown in **Reference 4**, sedimentation basin footprints were positioned and evaluated to confirm that the minimum length to width ratios are sufficient. **Table 7**, below, summarizes the dimensions of each sediment basin proposed for the Site.

Sediment Basin ID	Basin Length (ft)	Basin Width (ft)	Ratio Provided (L:W)	Ratio Provided > Ratio Required
PT-SB-1	535	147	4 :1	YES
W-SB-1	308	148	2 :1	YES
P-SB-1	670	170	4 :1	YES
P-SB-2	324	136	2 :1	YES
P-SB-3	414	126	3 :1	YES
NE-SB-1	479	129	4 :1	YES
NE-SB-2	284	114	2 :1	YES
NE-SB-3	350	175	2 :1	YES
NE-SB-4	342	155	2 :1	YES



### 1.3 Estimate Sediment Storage Volume

SCDHEC requires the minimum sediment storage volume for a sediment basin to be equal to 3,600 cubic feet of sediment storage volume per acre of drainage area (**Reference 7**). Furthermore, twenty percent (20%) of the sediment storage volume is to be provided within the sediment forebay(s). Stage-storage volumes for each sediment basin were developed from the bottom of basin to the crest perimeter berm or dike. Stage-storage volumes were estimated using the prismatic stage-storage volume calculation method developed from preliminary design surfaces developed within AutoCAD® Civil 3D®. Stage-storage information was input into HydroCAD® at one-foot contour intervals to model each sediment basin as a pond. The estimated required sediment storage volume using the disturbed area and the total storage volume are shown below within **Table 8**.

Table 8: Sediment Basin Volume Summary				
Sediment Basin ID	Drainage Area {A} (acres)	Volume Required (ft <sup>3</sup> )	Volume Provided (ft <sup>3</sup> )	Volume Provided > Volume Required
PT-SB-1	23.24	83666	385437	YES
W-SB-1	13.77	49576	231602	YES
P-SB-1	44.47	160082	728747	YES
P-SB-2	13.84	49839	226191	YES
P-SB-3	20.31	73129	332353	YES
NE-SB-1	20.80	74882	339759	YES
NE-SB-2	7.67	27604	143441	YES
NE-SB-3	10.13	36463	180679	YES
NE-SB-4	15.59	56130	253995	YES



## 1.4 Principal Spillway Design

Stormwater runoff for the 10-yr and 25-yr design storms were calculated within Section 1.1 of this calculation package. To compute, the full culvert pipe flow from the principal riser, the following equation was used:

$$Q = a(2gH)^{\frac{1}{2}} / (1 + K_e + K_b + K_c L)^{\frac{1}{2}} \quad \text{[Reference 8]}$$

Stormwater flow through the top of the principal riser or spillway was modeled as a weir and was calculated using the weir equation where  $Q = CLH^{3/2}$ , as implemented within HydroCAD®. The estimated water surface elevations for the 10-yr and 25-yr design storms for each basin were calculated and summarized in **Table 9** below.

Sediment Basin ID	Top and Bottom of Riser Elevation (ft)		Top of Dam Elevation (ft)	Riser Dimensions (ft)	Culvert Pipe Diameter (in.)	10-Year Water Surface Elevation (ft)	25-Year Water Surface Elevation (ft)	Freeboard* (ft)
PT-SB-1	562.7	557.0	565.0	3x3	24	562.68	562.96	2.04
W-SB-1	505.4	500.0	508.0	3x3	24	505.39	505.62	2.38
P-SB-1	457.4	450.0	460.0	3x3	24	457.36	457.78	2.22
P-SB-2	487.4	481.0	490.0	3x3	24	487.37	487.62	2.38
P-SB-3	497.3	490.0	500.0	3x3	24	497.29	497.57	2.43
NE-SB-1	434.4	427.0	437.0	3x3	24	434.36	434.66	2.34
NE-SB-2	416.8	412.0	420.0	3x3	24	416.75	416.97	3.03
NE-SB-3	418.0	412.0	421.0	3x3	24	417.98	418.19	2.81
NE-SB-4	484.5	479.0	487.0	3x3	24	484.40	484.73	2.27

\*Freeboard measured from 25-year water surface elevation to the top of dam elevation

As shown above, each sediment basin contains the 10-year design storm without activating the principal spillway riser.





### 1.5 Emergency Spillway Design for a 100-Year Design Storm.

Weir flow through the emergency spillway was calculated using the weir equation  $Q=CLH^{3/2}$  as implemented within HydroCAD®. The discharge to each sediment basin during the 100-year design storm was calculated in HydroCAD® as recorded in **Table 6**. North American Green EroNet P300 matting (Manning’s number of 0.034) was proposed to line the emergency spillway and down slope area to resist erosive forces, if the emergency spillway were to be activated. Although the 100-yr storm does not activate the emergency spillways of each sediment basin except for P-SB-1, this sediment basin was designed to maintain a minimum 0.5 foot freeboard during the 100-yr storm (**Reference 7**). The emergency spillway of P-SB-1 is activated during the 100-year storm and continues to maintain a minimum 0.5 ft freeboard. The emergency spillway design is shown below in **Table 10**.

**Table 10: Emergency Spillway Design**

Sediment Basin ID	Top of Riser Elevation (ft)	Emergency Spillway Crest Elevation (ft)	Top of Dam Elevation (ft)	Emergency Spillway Slope (ft/ft)	Emergency Spillway Length (ft)	Emergency Spillway Breadth (ft)	Emergency Spillway Depth (ft)	100 Year Storm Water Elevation (ft)	Emergency Spillway Freeboard (ft)
PT-SB-1	562.7	563.7	565.0	0.02	20	12.0	1.3	563.6	1.4
W-SB-1	505.4	506.4	508.0	0.02	20	12.0	1.6	506.2	1.8
P-SB-1	457.4	458.4	460.0	0.02	20	12.0	1.6	458.7	1.3
P-SB-2	487.4	488.4	490.0	0.02	20	12.0	1.6	488.3	1.8
P-SB-3	497.3	498.3	500.0	0.02	20	12.0	1.7	498.3	1.7
NE-SB-1	434.4	435.4	437.0	0.02	20	12.0	1.6	435.4	1.6
NE-SB-2	416.8	417.8	420.0	0.02	20	12.0	2.2	417.5	2.5
NE-SB-3	418.0	419.0	421.0	0.02	20	12.0	2.0	418.8	2.2
NE-SB-4	484.5	485.5	487.0	0.02	20	12.0	1.5	485.4	1.6



### 1.6 Size Anti-Flotation Block

An anti-flotation block was designed for each sediment basin such that the weight of the anti-flotation block (including the riser concrete walls) was at least 10% more than the weight of the water displaced (**Reference 7**) (or uplift force on the riser). The anti-flotation block was estimated based on a rectangular base and thickness as shown below:

$$W_{AB} = L_{AB1} \times L_{AB2} \times H_{AB} \times \gamma_c$$

The uplift pressure was computed as:

$$U_{riser} = [H \times A_r \times \gamma_w] + [L_{AB} \times L_{AB1} \times H_{AB2} \times \gamma_w]$$

The anti-flotation block sizing was designed as shown in **Table 11** below. For construction purposes, each anti-flotation block was considered equivalent to a 3-ft × 3-ft precast concrete riser with a 6-in. thick concrete floor.

Table 11: Anti-Flotation Block Design											
Sediment Basin ID	Bottom of Basin Elevation (ft)	Top of Riser Elevation (ft)	Riser Height {H} (ft)	Riser Area {A <sub>r</sub> } (ft <sup>2</sup> )	Uplift Force on Riser {U <sub>riser</sub> } (lb)	Height of Anti-Flotation Block {H <sub>AB</sub> } (ft)	Anti-Flotation Block Area {A <sub>r</sub> } (ft <sup>2</sup> )	Weight of Anti-Flotation Block {W <sub>AB</sub> } (lb)	Weight of Concrete Walls (lb)	Weight of Concrete Total (lb)	Safety Factor Against Uplift
PT-SB-1	557.0	562.7	5.7	9.00	3,201	0.50	9.00	675	5,985	6,660	2.08
W-SB-1	500.0	505.4	5.4	9.00	3,033	0.50	9.00	675	5,670	6,345	2.09
P-SB-1	450.0	457.4	7.4	9.00	4,156	0.50	9.00	675	7,770	8,445	2.03
P-SB-2	481.0	487.4	6.4	9.00	3,594	0.50	9.00	675	6,720	7,395	2.06
P-SB-3	490.0	497.3	7.3	9.00	4,100	0.50	9.00	675	7,665	8,340	2.03
NE-SB-1	427.0	434.4	7.4	9.00	4,156	0.50	9.00	675	7,770	8,445	2.03
NE-SB-2	412.0	416.8	4.8	9.00	2,696	0.50	9.00	675	5,040	5,715	2.12
NE-SB-3	412.0	418.0	6.0	9.00	3,370	0.50	9.00	675	6,300	6,975	2.07
NE-SB-4	479.0	484.5	5.5	9.00	3,089	0.50	9.00	675	5,775	6,450	2.09



## 1.7 Estimate Skimmer Sizes

Skimmers were designed to drain the storage volume of water contained during a 10-yr, 24-hr storm event within two to five days (48-120 hours) (**Reference 7**). Sediment basin volumes are provided in **Table 8**.

To select the orifice sizes required to drain the proposed sediment storage volume in two to five days, the following equations were applied:

$$A_o = \frac{V_{required}}{Factor} \quad \text{[Reference 9]}$$

With the known orifice area required, the orifice diameter is calculated using the follow equation:

$$d = \sqrt{\frac{A_o}{\pi}} * 2 \quad \text{[Reference 9]}$$

The estimated skimmer sizes, orifice diameters, and drain times were calculated as shown in **Table 12** below.

Table 12: Skimmer Size and Orifice Diameter Summary								
Sediment Basin ID	Volume Below Principal Crest {V <sub>necessary</sub> } (ft <sup>3</sup> )	Skimmer Size [Ref. 9] (in.)	Factor [Ref. ]	Required Orifice Area {A <sub>o</sub> } (in. <sup>2</sup> )	Orifice Diameter* (in.)	Number of Skimmers	Orifice flow (cfs)	Drain Time (hr)
PT-SB-1	375,090	8.0	5,961	62.92	8.00	1.00	1.168	89.2
W-SB-1	222,260	8.0	5,961	37.29	7.00	1.00	0.894	69.0
P-SB-1	717,681	8.0	5,961	120.40	8.00	2.00	2.336	85.3
P-SB-2	223,437	8.0	5,961	37.48	7.00	1.00	0.894	69.4
P-SB-3	327,851	8.0	5,442	60.24	8.00	1.00	1.168	78.0
NE-SB-1	335,712	8.0	5,961	56.32	8.00	1.00	1.168	79.8
NE-SB-2	123,755	6.0	5,442	22.74	6.00	1.00	0.600	57.3
NE-SB-3	163,469	8.0	5,961	27.42	6.00	1.00	0.657	69.1
NE-SB-4	251,642	8.0	5,961	42.21	8.00	1.00	1.168	59.8

\*Orifice diameter has been rounded up to the nearest inch.

HydroCAD® was utilized to compute the drawdown time for the 10-year, 24-hour storm scenario. As such, different diameter skimmers with different orifice diameters will be installed in each sediment basin with an invert of the basin floor.



### 1.8 Determine Trapping Efficiency.

SCDHEC requires that each sediment basin must have an 80% trapping efficiency of Total Suspended Solids (TSS) (**Reference 7**). Since each basin except P-SB-1 receive less than the drainage area limitation of 30 acres, the eroded particle size, settling velocity, surface area of the basin at riser, and the 10-year, 24-hour design storm peak outflow from the basin were utilized to calculate a Basin Ratio. The trapping efficiencies were calculated using information obtained from SC DHEC Appendix E (**Reference 10**) and the Basin Ratio to compute the trapping efficiency from SC DHEC Appendix K (**Reference 11**). Calculated findings for each of the sediment basins are summarized in **Table 13** below.

Sediment Basin ID	Watershed Area (acres)	Peak Outflow Rate {Q <sub>10</sub> } (cfs)	Surface Area at Riser Crest (acres)	Soil Classification	Soil Characteristic Diameter {D <sub>15</sub> } (mm)	Soil Characteristic Settling Velocity {V <sub>15</sub> } (fps)	Basin Ratio	Trapping Efficiency Acceptable?
PT-SB-1	23.2	1.168	1.44	Cecil	0.0066	1.22E-04	6644	>80% - GOOD
W-SB-1	13.8	0.894	0.85	Cecil	0.0066	1.22E-04	8556	>80% - GOOD
P-SB-1	44.5	-	-	Pacolet	-	-	-	-
P-SB-2	13.8	0.894	0.77	Pacolet	0.0053	7.89E-05	14702	>80% - GOOD
P-SB-3	20.3	1.168	1.01	Cecil	0.0066	1.22E-04	9442	>80% - GOOD
NE-SB-1	20.8	1.168	1.06	Pacolet	0.0053	7.89E-05	14013	>80% - GOOD
NE-SB-2	7.7	0.600	0.52	Pacolet	0.0053	7.89E-05	14539	>80% - GOOD
NE-SB-3	10.1	0.657	0.61	Pacolet	0.0053	7.89E-05	13752	>80% - GOOD
NE-SB-4	15.6	1.168	0.94	Pacolet	0.0053	7.89E-05	15669	>80% - GOOD

Since P-SB-1 contained a larger watershed (>30 acres) the computer model SEDIMOT IV was used to calculate the corresponding trapping efficiency. **Reference 6** contains the output from the computer model. **Table 14** below summarizes the trapping efficiencies.

Sediment Basin ID	Watershed Area (acres)	Sediment Trapping Efficiency (%)	Clay Trapping Efficiency (%)	Silt Trapping Efficiency (%)	Sand Trapping Efficiency (%)	Average Trapping Efficiency (%)	Trapping Efficiency Acceptable?
P-SB-1	44.5	99.2%	76.4%	96.0%	100.0%	92.9%	>80% - GOOD



### 1.9 Determine Anti-Seep Collar Size.

An anti-seep collar will be installed along the principal spillway culvert downstream of the sediment basin (**Reference 7**). The anti-seep collar size was calculated to project at least 1.5 feet from the culvert pipe as shown in **Table 15** below.

Sediment Basin ID	Outlet Pipe Diameter (in)	Anti-Seep Collar Size (ft)
PT-SB-1	24	5
W-SB-1	24	5
P-SB-1	24	5
P-SB-2	24	5
P-SB-3	24	5
NE-SB-1	24	5
NE-SB-2	24	5
NE-SB-3	24	5
NE-SB-4	24	5



**1.10** Compute Peak Water Elevations during design storms.

For each design storm, HydroCAD® was used to calculate the peak inflow, outflow, and peak stage elevations, these are summarized in **Tables 16A and 16B**, below.

Table 16A: Sediment Basin Design Storm Elevations			
Design Storm	Peak Inflow (cfs)	Peak Outflow (cfs)	Peak Water Elevation (ft)
<b>PT-SB-1</b>			
2-yr	90.21	1.17	560.71
10-yr	135.91	1.17	562.68
25-yr	166.47	6.41	562.96
100-yr	218.38	33.36	563.58
<b>W-SB-1</b>			
2-yr	60.08	0.89	503.48
10-yr	90.38	0.89	505.39
25-yr	110.63	4.93	505.62
100-yr	145.49	29.49	506.21
<b>P-SB-1</b>			
2-yr	159.90	2.34	454.83
10-yr	241.19	2.34	457.36
25-yr	295.54	11.54	457.78
100-yr	389.04	49.88	458.68
<b>P-SB-2</b>			
2-yr	59.30	0.89	485.21
10-yr	89.23	0.89	487.37
25-yr	109.25	5.03	487.62
100-yr	143.69	31.71	488.25
<b>P-SB-3</b>			
2-yr	85.00	1.17	494.84
10-yr	127.96	1.17	497.29
25-yr	156.69	6.76	497.57
100-yr	206.12	39.99	498.29

Table 16B: Sediment Basin Design Storm Elevations			
Design Storm	Peak Inflow (cfs)	Peak Outflow (cfs)	Peak Water Elevation (ft)
<b>NE-SB-1</b>			
2-yr	84.97	1.17	431.93
10-yr	127.97	1.17	434.36
25-yr	156.73	6.55	434.66
100-yr	206.20	38.40	435.36
<b>NE-SB-2</b>			
2-yr	34.49	0.66	415.11
10-yr	51.88	0.66	416.75
25-yr	63.51	3.52	416.97
100-yr	83.52	24.17	417.51
<b>NE-SB-3</b>			
2-yr	45.15	0.66	415.98
10-yr	67.89	0.66	417.98
25-yr	83.09	3.87	418.19
100-yr	109.26	26.41	418.76
<b>NE-SB-4</b>			
2-yr	66.78	1.17	482.49
10-yr	100.49	1.17	484.40
25-yr	123.04	5.51	484.73
100-yr	161.83	31.74	485.35



## ❖ 2.0 PLUNGE POOL SIZING

The riprap plunge pool design was developed using NRCS's "Riprap Lined Plunge Pool for Cantilever Outlet" excel spreadsheet (**Reference 12**). The plunge pools were designed based on the peak outflow during the 25-yr, 24-hr storm event and the calculation spreadsheets are provided in **Reference 13**.

## ❖ DISCUSSION

As a result of the proposed grading and construction on the project site, nine (9) separate drainage areas were delineated for 'during construction' conditions. Subsequently, nine (9) sediment basins were designed and will be implemented as a means to control peak stormwater flows from the 10-yr, 25-yr, and 100-yr, 24-hr storm event. Sediment basin designs were found to meet the requirements outlined in **Reference 7**.

## References



## **Reference 1**

*NOAA Atlas 14, Volume 2, Version 3*, Bonnin, G.M., Martin, D., Lin, B., Parzybok, T., Yekta, M., & Riley, D., April 21, 2017.



**NOAA Atlas 14, Volume 2, Version 3**  
**Location name: Ridgeway, South Carolina, USA\***  
**Latitude: 34.3147°, Longitude: -81.0197°**  
**Elevation: 505.7 ft\*\***  
\* source: ESRI Maps  
\*\* source: USGS



**POINT PRECIPITATION FREQUENCY ESTIMATES**

G.M. Bonnin, D. Martin, B. Lin, T. Parzybok, M.Yekta, and D. Riley

NOAA, National Weather Service, Silver Spring, Maryland

[PF\\_tabular](#) | [PF\\_graphical](#) | [Maps\\_&\\_aerials](#)

**PF tabular**

<b>PDS-based point precipitation frequency estimates with 90% confidence intervals (in inches)<sup>1</sup></b>										
Duration	Average recurrence interval (years)									
	1	2	5	10	25	50	100	200	500	1000
<b>5-min</b>	<b>0.429</b> (0.395-0.469)	<b>0.501</b> (0.460-0.548)	<b>0.577</b> (0.530-0.631)	<b>0.643</b> (0.588-0.701)	<b>0.719</b> (0.656-0.783)	<b>0.778</b> (0.706-0.847)	<b>0.834</b> (0.754-0.907)	<b>0.888</b> (0.797-0.968)	<b>0.954</b> (0.850-1.04)	<b>1.01</b> (0.890-1.10)
<b>10-min</b>	<b>0.686</b> (0.631-0.748)	<b>0.801</b> (0.735-0.876)	<b>0.924</b> (0.848-1.01)	<b>1.03</b> (0.941-1.12)	<b>1.15</b> (1.05-1.25)	<b>1.24</b> (1.12-1.35)	<b>1.33</b> (1.20-1.44)	<b>1.41</b> (1.26-1.53)	<b>1.51</b> (1.35-1.65)	<b>1.59</b> (1.40-1.73)
<b>15-min</b>	<b>0.857</b> (0.789-0.935)	<b>1.01</b> (0.924-1.10)	<b>1.17</b> (1.07-1.28)	<b>1.30</b> (1.19-1.42)	<b>1.45</b> (1.33-1.58)	<b>1.57</b> (1.42-1.71)	<b>1.68</b> (1.51-1.82)	<b>1.78</b> (1.59-1.94)	<b>1.90</b> (1.69-2.07)	<b>1.99</b> (1.76-2.17)
<b>30-min</b>	<b>1.18</b> (1.08-1.28)	<b>1.39</b> (1.28-1.52)	<b>1.66</b> (1.53-1.82)	<b>1.88</b> (1.73-2.06)	<b>2.15</b> (1.96-2.34)	<b>2.36</b> (2.14-2.57)	<b>2.57</b> (2.32-2.79)	<b>2.77</b> (2.48-3.01)	<b>3.02</b> (2.69-3.30)	<b>3.22</b> (2.85-3.52)
<b>60-min</b>	<b>1.47</b> (1.35-1.60)	<b>1.75</b> (1.60-1.91)	<b>2.13</b> (1.96-2.33)	<b>2.45</b> (2.25-2.68)	<b>2.87</b> (2.61-3.12)	<b>3.20</b> (2.90-3.49)	<b>3.54</b> (3.19-3.85)	<b>3.88</b> (3.48-4.22)	<b>4.34</b> (3.86-4.73)	<b>4.70</b> (4.16-5.14)
<b>2-hr</b>	<b>1.67</b> (1.53-1.83)	<b>1.99</b> (1.83-2.18)	<b>2.45</b> (2.24-2.68)	<b>2.85</b> (2.60-3.11)	<b>3.37</b> (3.06-3.67)	<b>3.81</b> (3.45-4.15)	<b>4.27</b> (3.84-4.64)	<b>4.75</b> (4.25-5.16)	<b>5.41</b> (4.78-5.88)	<b>5.96</b> (5.23-6.50)
<b>3-hr</b>	<b>1.76</b> (1.61-1.94)	<b>2.10</b> (1.92-2.31)	<b>2.60</b> (2.37-2.86)	<b>3.03</b> (2.76-3.33)	<b>3.63</b> (3.29-3.98)	<b>4.15</b> (3.73-4.53)	<b>4.69</b> (4.19-5.13)	<b>5.28</b> (4.68-5.77)	<b>6.12</b> (5.36-6.69)	<b>6.84</b> (5.92-7.47)
<b>6-hr</b>	<b>2.09</b> (1.91-2.32)	<b>2.50</b> (2.28-2.77)	<b>3.09</b> (2.81-3.42)	<b>3.61</b> (3.28-3.99)	<b>4.35</b> (3.92-4.79)	<b>4.98</b> (4.46-5.47)	<b>5.65</b> (5.03-6.20)	<b>6.38</b> (5.63-6.98)	<b>7.43</b> (6.46-8.12)	<b>8.34</b> (7.16-9.13)
<b>12-hr</b>	<b>2.47</b> (2.24-2.76)	<b>2.95</b> (2.67-3.29)	<b>3.66</b> (3.31-4.08)	<b>4.30</b> (3.87-4.77)	<b>5.21</b> (4.67-5.76)	<b>6.00</b> (5.33-6.63)	<b>6.84</b> (6.03-7.56)	<b>7.78</b> (6.79-8.58)	<b>9.14</b> (7.84-10.1)	<b>10.3</b> (8.74-11.4)
<b>24-hr</b>	<b>2.94</b> (2.75-3.16)	<b>3.54</b> (3.30-3.80)	<b>4.41</b> (4.11-4.73)	<b>5.14</b> (4.78-5.51)	<b>6.22</b> (5.74-6.66)	<b>7.12</b> (6.54-7.62)	<b>8.09</b> (7.38-8.68)	<b>9.15</b> (8.27-9.83)	<b>10.7</b> (9.55-11.5)	<b>12.0</b> (10.6-12.9)
<b>2-day</b>	<b>3.47</b> (3.24-3.72)	<b>4.16</b> (3.89-4.46)	<b>5.16</b> (4.81-5.53)	<b>5.98</b> (5.58-6.41)	<b>7.17</b> (6.64-7.67)	<b>8.15</b> (7.51-8.74)	<b>9.20</b> (8.42-9.87)	<b>10.3</b> (9.39-11.1)	<b>11.9</b> (10.7-12.9)	<b>13.2</b> (11.8-14.4)
<b>3-day</b>	<b>3.69</b> (3.45-3.94)	<b>4.42</b> (4.13-4.72)	<b>5.46</b> (5.09-5.83)	<b>6.31</b> (5.88-6.74)	<b>7.52</b> (6.97-8.03)	<b>8.52</b> (7.86-9.11)	<b>9.58</b> (8.79-10.3)	<b>10.7</b> (9.76-11.5)	<b>12.3</b> (11.1-13.3)	<b>13.6</b> (12.2-14.7)
<b>4-day</b>	<b>3.90</b> (3.65-4.17)	<b>4.68</b> (4.38-4.99)	<b>5.75</b> (5.38-6.13)	<b>6.63</b> (6.19-7.06)	<b>7.87</b> (7.31-8.39)	<b>8.88</b> (8.22-9.48)	<b>9.96</b> (9.16-10.6)	<b>11.1</b> (10.1-11.9)	<b>12.7</b> (11.5-13.7)	<b>14.0</b> (12.6-15.1)
<b>7-day</b>	<b>4.53</b> (4.27-4.81)	<b>5.40</b> (5.09-5.73)	<b>6.57</b> (6.18-6.97)	<b>7.54</b> (7.07-7.99)	<b>8.89</b> (8.32-9.43)	<b>10.0</b> (9.32-10.6)	<b>11.2</b> (10.3-11.9)	<b>12.4</b> (11.4-13.2)	<b>14.2</b> (12.9-15.2)	<b>15.6</b> (14.0-16.8)
<b>10-day</b>	<b>5.15</b> (4.87-5.45)	<b>6.12</b> (5.78-6.48)	<b>7.38</b> (6.96-7.80)	<b>8.40</b> (7.91-8.87)	<b>9.84</b> (9.23-10.4)	<b>11.0</b> (10.3-11.6)	<b>12.2</b> (11.4-12.9)	<b>13.5</b> (12.4-14.3)	<b>15.3</b> (14.0-16.3)	<b>16.7</b> (15.2-18.0)
<b>20-day</b>	<b>6.89</b> (6.53-7.26)	<b>8.14</b> (7.72-8.57)	<b>9.61</b> (9.11-10.1)	<b>10.8</b> (10.2-11.4)	<b>12.4</b> (11.7-13.1)	<b>13.7</b> (12.8-14.4)	<b>14.9</b> (14.0-15.8)	<b>16.2</b> (15.1-17.2)	<b>18.0</b> (16.7-19.1)	<b>19.3</b> (17.8-20.6)
<b>30-day</b>	<b>8.47</b> (8.05-8.89)	<b>9.97</b> (9.48-10.5)	<b>11.6</b> (11.0-12.2)	<b>12.9</b> (12.3-13.6)	<b>14.7</b> (13.9-15.4)	<b>16.0</b> (15.1-16.8)	<b>17.3</b> (16.3-18.2)	<b>18.6</b> (17.4-19.6)	<b>20.2</b> (18.9-21.4)	<b>21.5</b> (20.0-22.8)
<b>45-day</b>	<b>10.5</b> (10.0-11.0)	<b>12.3</b> (11.8-12.9)	<b>14.2</b> (13.5-14.9)	<b>15.6</b> (14.9-16.4)	<b>17.5</b> (16.6-18.3)	<b>18.9</b> (17.9-19.8)	<b>20.3</b> (19.2-21.3)	<b>21.6</b> (20.4-22.7)	<b>23.3</b> (21.9-24.6)	<b>24.6</b> (23.0-26.0)
<b>60-day</b>	<b>12.5</b> (12.0-13.1)	<b>14.7</b> (14.1-15.3)	<b>16.7</b> (16.0-17.5)	<b>18.3</b> (17.5-19.1)	<b>20.3</b> (19.3-21.1)	<b>21.7</b> (20.7-22.6)	<b>23.1</b> (21.9-24.1)	<b>24.3</b> (23.1-25.5)	<b>25.9</b> (24.5-27.2)	<b>27.0</b> (25.5-28.4)

<sup>1</sup> Precipitation frequency (PF) estimates in this table are based on frequency analysis of partial duration series (PDS). Numbers in parenthesis are PF estimates at lower and upper bounds of the 90% confidence interval. The probability that precipitation frequency estimates (for a given duration and average recurrence interval) will be greater than the upper bound (or less than the lower bound) is 5%. Estimates at upper bounds are not checked against probable maximum precipitation (PMP) estimates and may be higher than currently valid PMP values. Please refer to NOAA Atlas 14 document for more information.

[Back to Top](#)

**PF graphical**

PDS-based depth-duration-frequency (DDF) curves

Latitude: 34.3147°, Longitude: -81.0197°

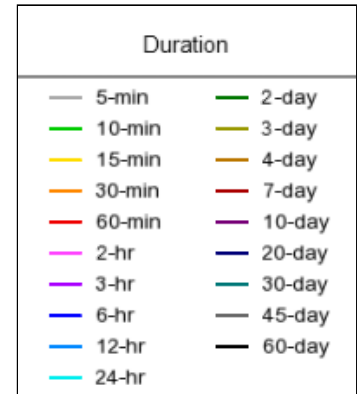
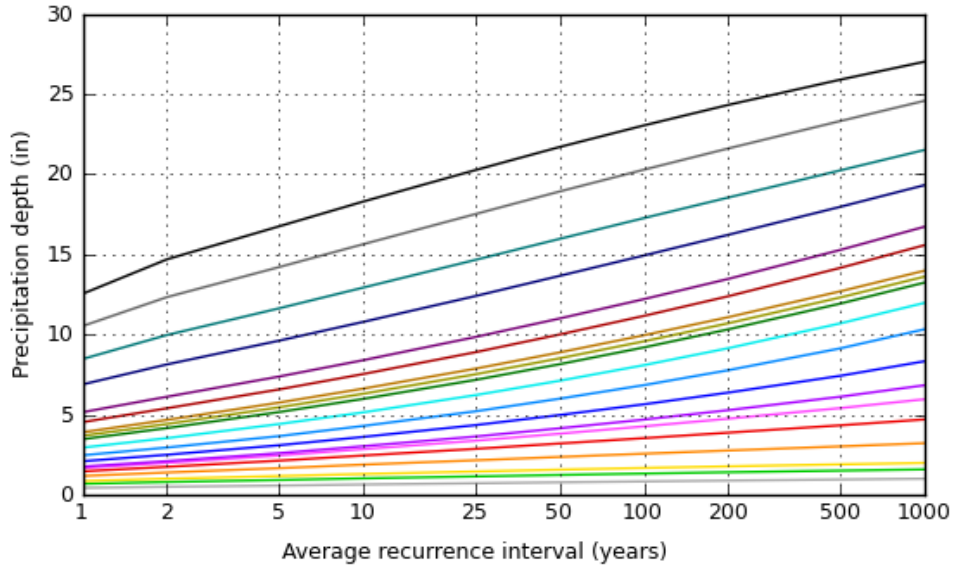
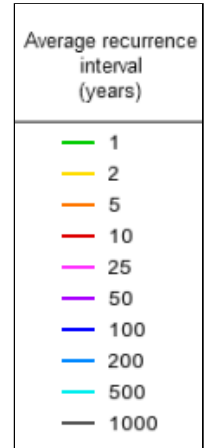
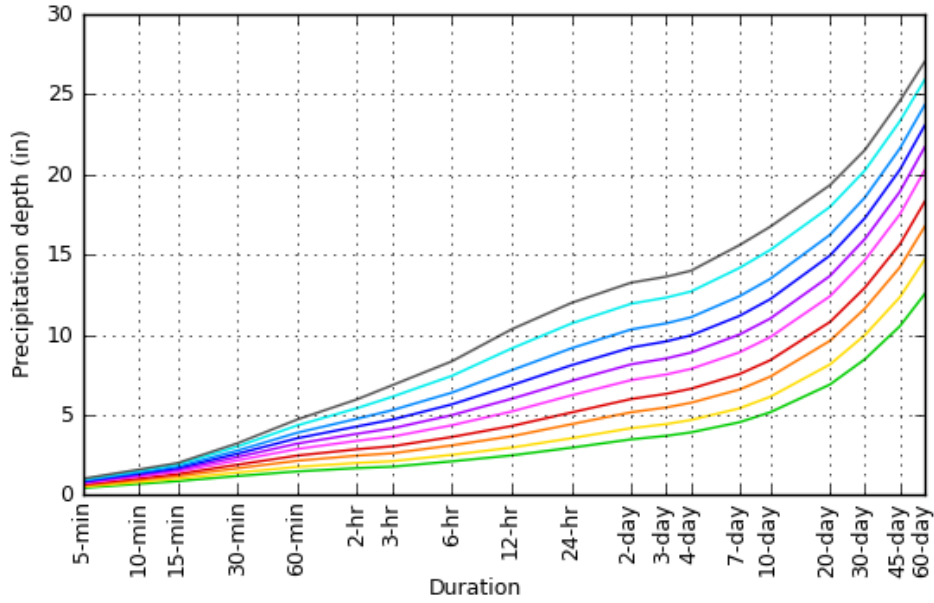

[Back to Top](#)

**Maps & aerials**

**Small scale terrain**

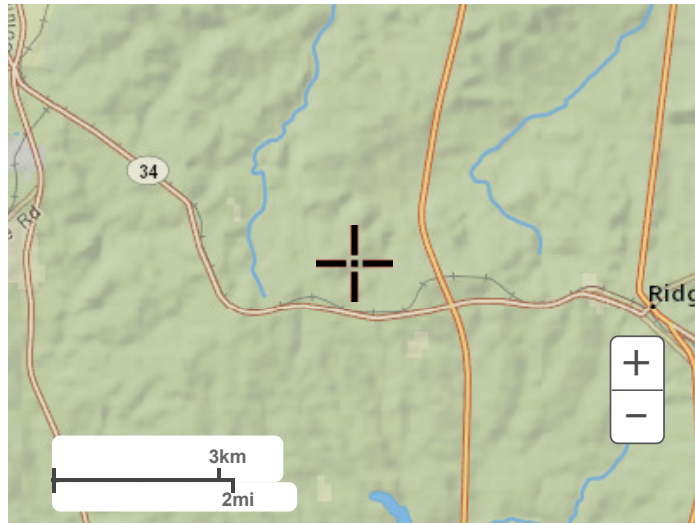

Large scale terrain



Large scale map



Large scale aerial

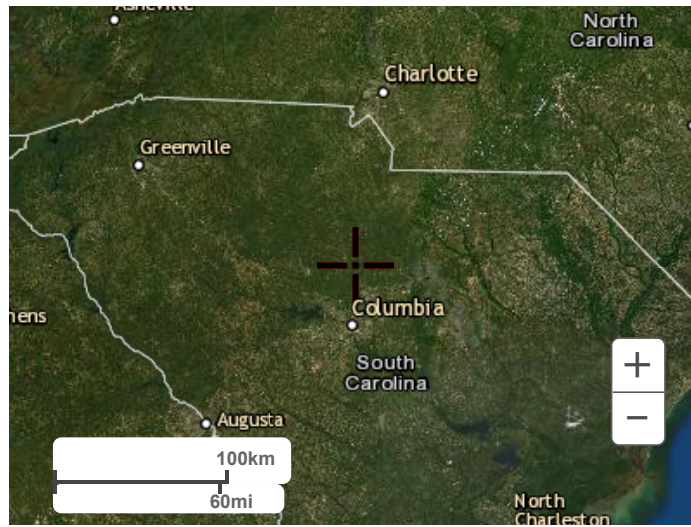

[Back to Top](#)

---

[US Department of Commerce](#)  
[National Oceanic and Atmospheric Administration](#)  
[National Weather Service](#)  
[National Water Center](#)  
1325 East West Highway  
Silver Spring, MD 20910  
Questions?: [HDSC.Questions@noaa.gov](mailto:HDSC.Questions@noaa.gov)

[Disclaimer](#)

## **Reference 2**

TR-55 Urban Hydrology for Small Watersheds, USDA-NRCS, June 1986.

## SCS runoff curve number method

The SCS Runoff Curve Number (CN) method is described in detail in NEH-4 (SCS 1985). The SCS runoff equation is

$$Q = \frac{(P - I_a)^2}{(P - I_a) + S} \quad [\text{eq. 2-1}]$$

where

- Q = runoff (in)
- P = rainfall (in)
- S = potential maximum retention after runoff begins (in) and
- I<sub>a</sub> = initial abstraction (in)

Initial abstraction (I<sub>a</sub>) is all losses before runoff begins. It includes water retained in surface depressions, water intercepted by vegetation, evaporation, and infiltration. I<sub>a</sub> is highly variable but generally is correlated with soil and cover parameters. Through studies of many small agricultural watersheds, I<sub>a</sub> was found to be approximated by the following empirical equation:

$$I_a = 0.2S \quad [\text{eq. 2-2}]$$

By removing I<sub>a</sub> as an independent parameter, this approximation allows use of a combination of S and P to produce a unique runoff amount. Substituting equation 2-2 into equation 2-1 gives:

$$Q = \frac{(P - 0.2S)^2}{(P + 0.8S)} \quad [\text{eq. 2-3}]$$

S is related to the soil and cover conditions of the watershed through the CN. CN has a range of 0 to 100, and S is related to CN by:

$$S = \frac{1000}{CN} - 10 \quad [\text{eq. 2-4}]$$

Figure 2-1 and table 2-1 solve equations 2-3 and 2-4 for a range of CN's and rainfall.

## Factors considered in determining runoff curve numbers

The major factors that determine CN are the hydrologic soil group (HSG), cover type, treatment, hydrologic condition, and antecedent runoff condition (ARC). Another factor considered is whether impervious areas outlet directly to the drainage system (connected) or whether the flow spreads over pervious areas before entering the drainage system (unconnected). Figure 2-2 is provided to aid in selecting the appropriate figure or table for determining curve numbers.

CN's in table 2-2 (*a* to *d*) represent average antecedent runoff condition for urban, cultivated agricultural, other agricultural, and arid and semiarid rangeland uses. Table 2-2 assumes impervious areas are directly connected. The following sections explain how to determine CN's and how to modify them for urban conditions.

### Hydrologic soil groups

Infiltration rates of soils vary widely and are affected by subsurface permeability as well as surface intake rates. Soils are classified into four HSG's (A, B, C, and D) according to their minimum infiltration rate, which is obtained for bare soil after prolonged wetting. Appendix A defines the four groups and provides a list of most of the soils in the United States and their group classification. The soils in the area of interest may be identified from a soil survey report, which can be obtained from local SCS offices or soil and water conservation district offices.

Most urban areas are only partially covered by impervious surfaces: the soil remains an important factor in runoff estimates. Urbanization has a greater effect on runoff in watersheds with soils having high infiltration rates (sands and gravels) than in watersheds predominantly of silts and clays, which generally have low infiltration rates.

Any disturbance of a soil profile can significantly change its infiltration characteristics. With urbanization, native soil profiles may be mixed or removed or fill material from other areas may be introduced. Therefore, a method based on soil texture is given in appendix A for determining the HSG classification for disturbed soils.

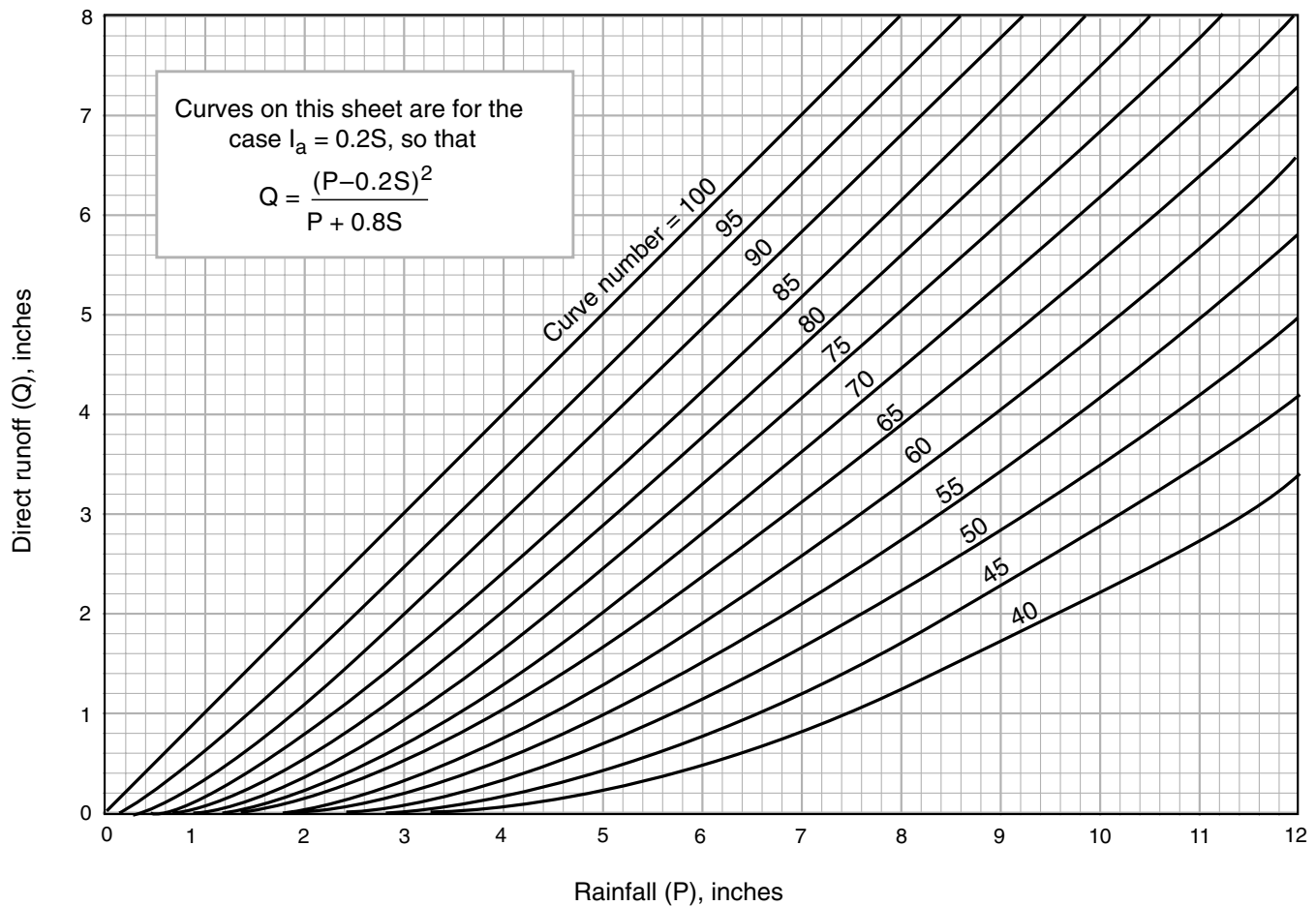
**Figure 2-1** Solution of runoff equation.

### Cover type

Table 2-2 addresses most cover types, such as vegetation, bare soil, and impervious surfaces. There are a number of methods for determining cover type. The most common are field reconnaissance, aerial photographs, and land use maps.

### Treatment

**Treatment** is a cover type modifier (used only in table 2-2b) to describe the management of cultivated agricultural lands. It includes mechanical practices, such as contouring and terracing, and management practices, such as crop rotations and reduced or no tillage.

### Hydrologic condition

**Hydrologic condition** indicates the effects of cover type and treatment on infiltration and runoff and is generally estimated from density of plant and residue cover on sample areas. **Good** hydrologic condition indicates that the soil usually has a low runoff potential for that specific hydrologic soil group, cover type, and treatment. Some factors to consider in estimating the effect of cover on infiltration and runoff are (a) canopy or density of lawns, crops, or other vegetative areas; (b) amount of year-round cover; (c) amount of grass or close-seeded legumes in rotations; (d) percent of residue cover; and (e) degree of surface roughness.

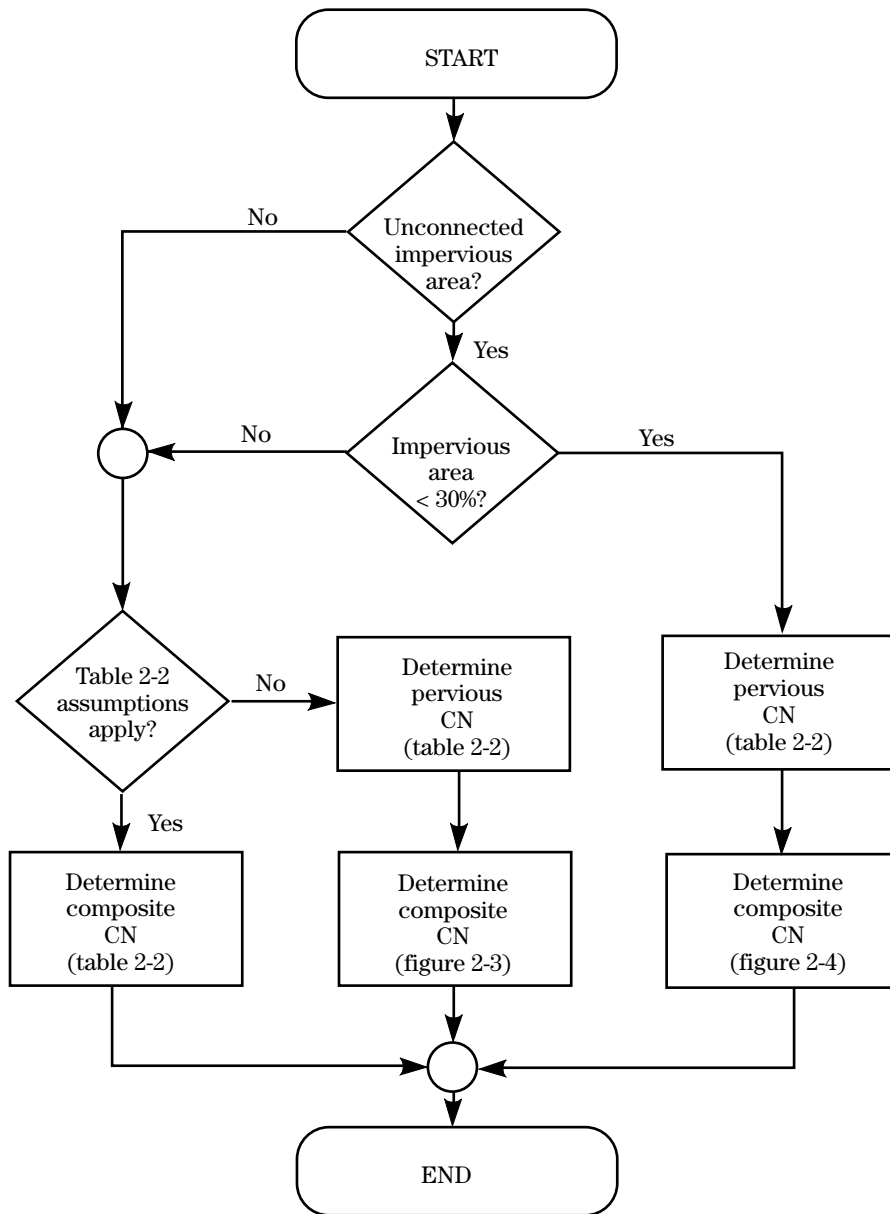

**Table 2-1** Runoff depth for selected CN's and rainfall amounts <sup>1/</sup>

Rainfall	Runoff depth for curve number of—												
	40	45	50	55	60	65	70	75	80	85	90	95	98
	inches												
1.0	0.00	0.00	0.00	0.00	0.00	0.00	0.00	0.03	0.08	0.17	0.32	0.56	0.79
1.2	.00	.00	.00	.00	.00	.00	.03	.07	.15	.27	.46	.74	.99
1.4	.00	.00	.00	.00	.00	.02	.06	.13	.24	.39	.61	.92	1.18
1.6	.00	.00	.00	.00	.01	.05	.11	.20	.34	.52	.76	1.11	1.38
1.8	.00	.00	.00	.00	.03	.09	.17	.29	.44	.65	.93	1.29	1.58
2.0	.00	.00	.00	.02	.06	.14	.24	.38	.56	.80	1.09	1.48	1.77
2.5	.00	.00	.02	.08	.17	.30	.46	.65	.89	1.18	1.53	1.96	2.27
3.0	.00	.02	.09	.19	.33	.51	.71	.96	1.25	1.59	1.98	2.45	2.77
3.5	.02	.08	.20	.35	.53	.75	1.01	1.30	1.64	2.02	2.45	2.94	3.27
4.0	.06	.18	.33	.53	.76	1.03	1.33	1.67	2.04	2.46	2.92	3.43	3.77
4.5	.14	.30	.50	.74	1.02	1.33	1.67	2.05	2.46	2.91	3.40	3.92	4.26
5.0	.24	.44	.69	.98	1.30	1.65	2.04	2.45	2.89	3.37	3.88	4.42	4.76
6.0	.50	.80	1.14	1.52	1.92	2.35	2.81	3.28	3.78	4.30	4.85	5.41	5.76
7.0	.84	1.24	1.68	2.12	2.60	3.10	3.62	4.15	4.69	5.25	5.82	6.41	6.76
8.0	1.25	1.74	2.25	2.78	3.33	3.89	4.46	5.04	5.63	6.21	6.81	7.40	7.76
9.0	1.71	2.29	2.88	3.49	4.10	4.72	5.33	5.95	6.57	7.18	7.79	8.40	8.76
10.0	2.23	2.89	3.56	4.23	4.90	5.56	6.22	6.88	7.52	8.16	8.78	9.40	9.76
11.0	2.78	3.52	4.26	5.00	5.72	6.43	7.13	7.81	8.48	9.13	9.77	10.39	10.76
12.0	3.38	4.19	5.00	5.79	6.56	7.32	8.05	8.76	9.45	10.11	10.76	11.39	11.76
13.0	4.00	4.89	5.76	6.61	7.42	8.21	8.98	9.71	10.42	11.10	11.76	12.39	12.76
14.0	4.65	5.62	6.55	7.44	8.30	9.12	9.91	10.67	11.39	12.08	12.75	13.39	13.76
15.0	5.33	6.36	7.35	8.29	9.19	10.04	10.85	11.63	12.37	13.07	13.74	14.39	14.76

<sup>1/</sup> Interpolate the values shown to obtain runoff depths for CN's or rainfall amounts not shown.

**Figure 2-2** Flow chart for selecting the appropriate figure or table for determining runoff curve numbers.



**Table 2-2a** Runoff curve numbers for urban areas <sup>1/</sup>

Cover description	Average percent impervious area <sup>2/</sup>	Curve numbers for hydrologic soil group			
		A	B	C	D
<b>Fully developed urban areas (vegetation established)</b>					
Open space (lawns, parks, golf courses, cemeteries, etc.) <sup>3/</sup> :					
Poor condition (grass cover < 50%) .....		68	79	86	89
Fair condition (grass cover 50% to 75%) .....		49	69	79	84
Good condition (grass cover > 75%) .....		39	61	74	80
Impervious areas:					
Paved parking lots, roofs, driveways, etc. (excluding right-of-way) .....		98	98	98	98
Streets and roads:					
Paved; curbs and storm sewers (excluding right-of-way) .....		98	98	98	98
Paved; open ditches (including right-of-way) .....		83	89	92	93
Gravel (including right-of-way) .....		76	85	89	91
Dirt (including right-of-way) .....		72	82	87	89
Western desert urban areas:					
Natural desert landscaping (pervious areas only) <sup>4/</sup> .....		63	77	85	88
Artificial desert landscaping (impervious weed barrier, desert shrub with 1- to 2-inch sand or gravel mulch and basin borders) .....		96	96	96	96
Urban districts:					
Commercial and business .....	85	89	92	94	95
Industrial .....	72	81	88	91	93
Residential districts by average lot size:					
1/8 acre or less (town houses) .....	65	77	85	90	92
1/4 acre .....	38	61	75	83	87
1/3 acre .....	30	57	72	81	86
1/2 acre .....	25	54	70	80	85
1 acre .....	20	51	68	79	84
2 acres .....	12	46	65	77	82

**Developing urban areas**

Newly graded areas  
(pervious areas only, no vegetation) <sup>5/</sup> .....

	77	86	91	94
--	----	----	----	----

Idle lands (CN's are determined using cover types  
similar to those in table 2-2c).

<sup>1</sup> Average runoff condition, and  $I_a = 0.2S$ .

<sup>2</sup> The average percent impervious area shown was used to develop the composite CN's. Other assumptions are as follows: impervious areas are directly connected to the drainage system, impervious areas have a CN of 98, and pervious areas are considered equivalent to open space in good hydrologic condition. CN's for other combinations of conditions may be computed using figure 2-3 or 2-4.

<sup>3</sup> CN's shown are equivalent to those of pasture. Composite CN's may be computed for other combinations of open space cover type.

<sup>4</sup> Composite CN's for natural desert landscaping should be computed using figures 2-3 or 2-4 based on the impervious area percentage (CN = 98) and the pervious area CN. The pervious area CN's are assumed equivalent to desert shrub in poor hydrologic condition.

<sup>5</sup> Composite CN's to use for the design of temporary measures during grading and construction should be computed using figure 2-3 or 2-4 based on the degree of development (impervious area percentage) and the CN's for the newly graded pervious areas.

**Table 2-2b** Runoff curve numbers for cultivated agricultural lands <sup>1/</sup>

Cover description			Curve numbers for hydrologic soil group			
Cover type	Treatment <sup>2/</sup>	Hydrologic condition <sup>3/</sup>	A	B	C	D
Fallow	Bare soil	—	77	86	91	94
	Crop residue cover (CR)	Poor	76	85	90	93
		Good	74	83	88	90
Row crops	Straight row (SR)	Poor	72	81	88	91
		Good	67	78	85	89
	SR + CR	Poor	71	80	87	90
		Good	64	75	82	85
	Contoured (C)	Poor	70	79	84	88
		Good	65	75	82	86
	C + CR	Poor	69	78	83	87
		Good	64	74	81	85
	Contoured & terraced (C&T)	Poor	66	74	80	82
		Good	62	71	78	81
C&T+ CR	Poor	65	73	79	81	
	Good	61	70	77	80	
Small grain	SR	Poor	65	76	84	88
		Good	63	75	83	87
	SR + CR	Poor	64	75	83	86
		Good	60	72	80	84
	C	Poor	63	74	82	85
		Good	61	73	81	84
	C + CR	Poor	62	73	81	84
		Good	60	72	80	83
	C&T	Poor	61	72	79	82
		Good	59	70	78	81
C&T+ CR	Poor	60	71	78	81	
	Good	58	69	77	80	
Close-seeded or broadcast legumes or rotation meadow	SR	Poor	66	77	85	89
		Good	58	72	81	85
	C	Poor	64	75	83	85
		Good	55	69	78	83
	C&T	Poor	63	73	80	83
		Good	51	67	76	80

<sup>1</sup> Average runoff condition, and  $I_a=0.2S$

<sup>2</sup> Crop residue cover applies only if residue is on at least 5% of the surface throughout the year.

<sup>3</sup> Hydraulic condition is based on combination factors that affect infiltration and runoff, including (a) density and canopy of vegetative areas, (b) amount of year-round cover, (c) amount of grass or close-seeded legumes, (d) percent of residue cover on the land surface (good  $\geq 20\%$ ), and (e) degree of surface roughness.

Poor: Factors impair infiltration and tend to increase runoff.

Good: Factors encourage average and better than average infiltration and tend to decrease runoff.

**Table 2-2c** Runoff curve numbers for other agricultural lands <sup>1/</sup>

Cover description	Hydrologic condition	Curve numbers for hydrologic soil group			
		A	B	C	D
Pasture, grassland, or range—continuous forage for grazing. <sup>2/</sup>	Poor	68	79	86	89
	Fair	49	69	79	84
	Good	39	61	74	80
Meadow—continuous grass, protected from grazing and generally mowed for hay.	—	30	58	71	78
Brush—brush-weed-grass mixture with brush the major element. <sup>3/</sup>	Poor	48	67	77	83
	Fair	35	56	70	77
	Good	30 <sup>4/</sup>	48	65	73
Woods—grass combination (orchard or tree farm). <sup>5/</sup>	Poor	57	73	82	86
	Fair	43	65	76	82
	Good	32	58	72	79
Woods. <sup>6/</sup>	Poor	45	66	77	83
	Fair	36	60	73	79
	Good	30 <sup>4/</sup>	55	70	77
Farmsteads—buildings, lanes, driveways, and surrounding lots.	—	59	74	82	86

<sup>1</sup> Average runoff condition, and  $I_a = 0.2S$ .

<sup>2</sup> **Poor:** <50% ground cover or heavily grazed with no mulch.

**Fair:** 50 to 75% ground cover and not heavily grazed.

**Good:** > 75% ground cover and lightly or only occasionally grazed.

<sup>3</sup> **Poor:** <50% ground cover.

**Fair:** 50 to 75% ground cover.

**Good:** >75% ground cover.

<sup>4</sup> Actual curve number is less than 30; use CN = 30 for runoff computations.

<sup>5</sup> CN's shown were computed for areas with 50% woods and 50% grass (pasture) cover. Other combinations of conditions may be computed from the CN's for woods and pasture.

<sup>6</sup> **Poor:** Forest litter, small trees, and brush are destroyed by heavy grazing or regular burning.

**Fair:** Woods are grazed but not burned, and some forest litter covers the soil.

**Good:** Woods are protected from grazing, and litter and brush adequately cover the soil.

**Table 2-2d** Runoff curve numbers for arid and semiarid rangelands <sup>1/</sup>

Cover description		Curve numbers for hydrologic soil group			
Cover type	Hydrologic condition <sup>2/</sup>	A <sup>3/</sup>	B	C	D
Herbaceous—mixture of grass, weeds, and low-growing brush, with brush the minor element.	Poor		80	87	93
	Fair		71	81	89
	Good		62	74	85
Oak-aspen—mountain brush mixture of oak brush, aspen, mountain mahogany, bitter brush, maple, and other brush.	Poor		66	74	79
	Fair		48	57	63
	Good		30	41	48
Pinyon-juniper—pinyon, juniper, or both; grass understory.	Poor		75	85	89
	Fair		58	73	80
	Good		41	61	71
Sagebrush with grass understory.	Poor		67	80	85
	Fair		51	63	70
	Good		35	47	55
Desert shrub—major plants include saltbush, greasewood, creosotebush, blackbrush, bursage, palo verde, mesquite, and cactus.	Poor	63	77	85	88
	Fair	55	72	81	86
	Good	49	68	79	84

<sup>1</sup> Average runoff condition, and  $I_a = 0.2S$ . For range in humid regions, use table 2-2c.

<sup>2</sup> Poor: <30% ground cover (litter, grass, and brush overstory).  
Fair: 30 to 70% ground cover.  
Good: > 70% ground cover.

<sup>3</sup> Curve numbers for group A have been developed only for desert shrub.

### Antecedent runoff condition

The index of runoff potential before a storm event is the antecedent runoff condition (ARC). ARC is an attempt to account for the variation in CN at a site from storm to storm. CN for the average ARC at a site is the median value as taken from sample rainfall and runoff data. The CN's in table 2-2 are for the average ARC, which is used primarily for design applications. See NEH-4 (SCS 1985) and Rallison and Miller (1981) for more detailed discussion of storm-to-storm variation and a demonstration of upper and lower enveloping curves.

### Urban impervious area modifications

Several factors, such as the percentage of impervious area and the means of conveying runoff from impervious areas to the drainage system, should be considered in computing CN for urban areas (Rawls et al., 1981). For example, do the impervious areas connect directly to the drainage system, or do they outlet onto lawns or other pervious areas where infiltration can occur?

**Connected impervious areas** — An impervious area is considered connected if runoff from it flows directly into the drainage system. It is also considered connected if runoff from it occurs as concentrated shallow flow that runs over a pervious area and then into the drainage system.

Urban CN's (table 2-2a) were developed for typical land use relationships based on specific assumed percentages of impervious area. These CN values were developed on the assumptions that (a) pervious urban areas are equivalent to pasture in good hydrologic condition and (b) impervious areas have a CN of 98 and are directly connected to the drainage system. Some assumed percentages of impervious area are shown in table 2-2a

If all of the impervious area is directly connected to the drainage system, but the impervious area percentages or the pervious land use assumptions in table 2-2a are not applicable, use figure 2-3 to compute a composite CN. For example, table 2-2a gives a CN of 70 for a 1/2-acre lot in HSG B, with assumed impervious area

of 25 percent. However, if the lot has 20 percent impervious area and a pervious area CN of 61, the composite CN obtained from figure 2-3 is 68. The CN difference between 70 and 68 reflects the difference in percent impervious area.

**Unconnected impervious areas** — Runoff from these areas is spread over a pervious area as sheet flow. To determine CN when all or part of the impervious area is not directly connected to the drainage system, (1) use figure 2-4 if total impervious area is less than 30 percent or (2) use figure 2-3 if the total impervious area is equal to or greater than 30 percent, because the absorptive capacity of the remaining pervious areas will not significantly affect runoff.

When impervious area is less than 30 percent, obtain the composite CN by entering the right half of figure 2-4 with the percentage of total impervious area and the ratio of total unconnected impervious area to total impervious area. Then move left to the appropriate pervious CN and read down to find the composite CN. For example, for a 1/2-acre lot with 20 percent total impervious area (75 percent of which is unconnected) and pervious CN of 61, the composite CN from figure 2-4 is 66. If all of the impervious area is connected, the resulting CN (from figure 2-3) would be 68.

**Figure 2-3** Composite CN with connected impervious area.

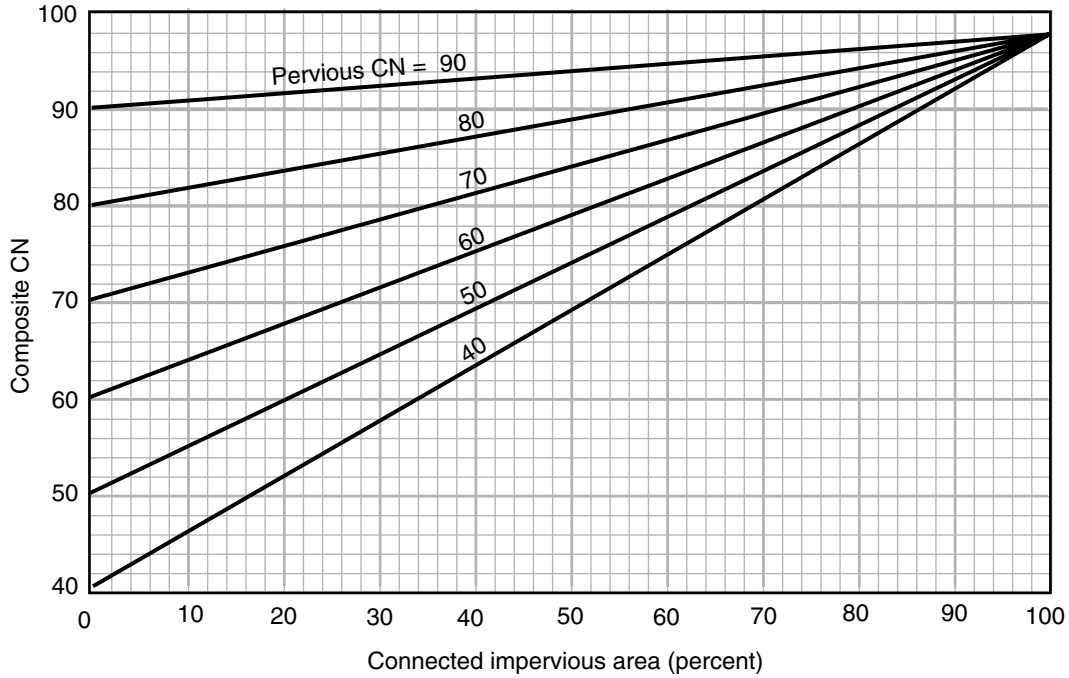

**Figure 2-4** Composite CN with unconnected impervious areas and total impervious area less than 30%.

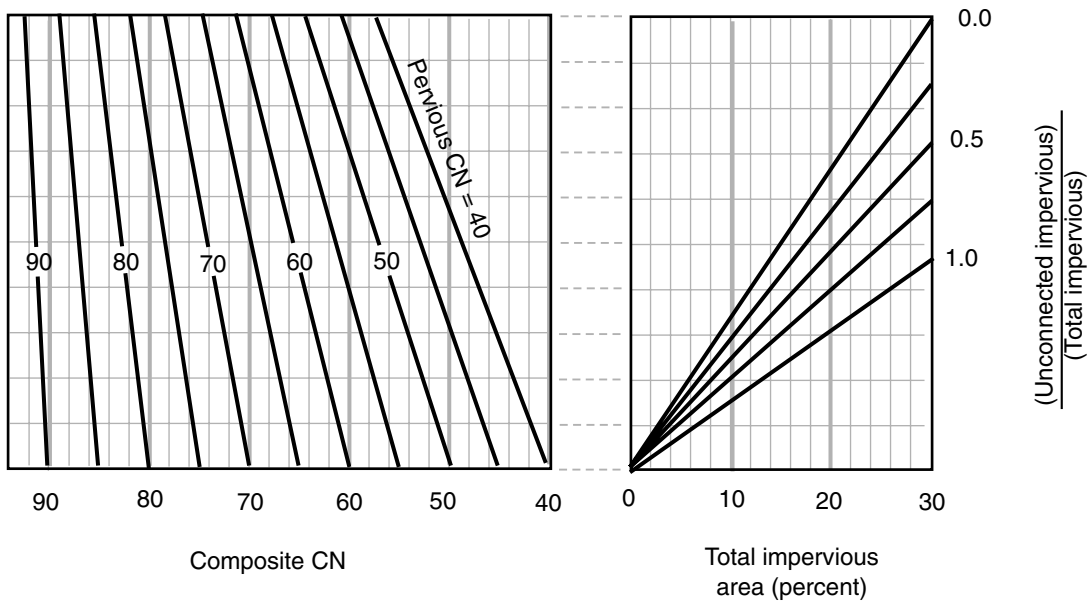



## **Reference 3**

*NRCS Soil Figures*, S&ME Inc., February 2021.

# Preface

---

Soil surveys contain information that affects land use planning in survey areas. They highlight soil limitations that affect various land uses and provide information about the properties of the soils in the survey areas. Soil surveys are designed for many different users, including farmers, ranchers, foresters, agronomists, urban planners, community officials, engineers, developers, builders, and home buyers. Also, conservationists, teachers, students, and specialists in recreation, waste disposal, and pollution control can use the surveys to help them understand, protect, or enhance the environment.

Various land use regulations of Federal, State, and local governments may impose special restrictions on land use or land treatment. Soil surveys identify soil properties that are used in making various land use or land treatment decisions. The information is intended to help the land users identify and reduce the effects of soil limitations on various land uses. The landowner or user is responsible for identifying and complying with existing laws and regulations.

Although soil survey information can be used for general farm, local, and wider area planning, onsite investigation is needed to supplement this information in some cases. Examples include soil quality assessments (<http://www.nrcs.usda.gov/wps/portal/nrcs/main/soils/health/>) and certain conservation and engineering applications. For more detailed information, contact your local USDA Service Center (<https://offices.sc.egov.usda.gov/locator/app?agency=nrcs>) or your NRCS State Soil Scientist ([http://www.nrcs.usda.gov/wps/portal/nrcs/detail/soils/contactus/?cid=nrcs142p2\\_053951](http://www.nrcs.usda.gov/wps/portal/nrcs/detail/soils/contactus/?cid=nrcs142p2_053951)).

Great differences in soil properties can occur within short distances. Some soils are seasonally wet or subject to flooding. Some are too unstable to be used as a foundation for buildings or roads. Clayey or wet soils are poorly suited to use as septic tank absorption fields. A high water table makes a soil poorly suited to basements or underground installations.

The National Cooperative Soil Survey is a joint effort of the United States Department of Agriculture and other Federal agencies, State agencies including the Agricultural Experiment Stations, and local agencies. The Natural Resources Conservation Service (NRCS) has leadership for the Federal part of the National Cooperative Soil Survey.

Information about soils is updated periodically. Updated information is available through the NRCS Web Soil Survey, the site for official soil survey information.

The U.S. Department of Agriculture (USDA) prohibits discrimination in all its programs and activities on the basis of race, color, national origin, age, disability, and where applicable, sex, marital status, familial status, parental status, religion, sexual orientation, genetic information, political beliefs, reprisal, or because all or a part of an individual's income is derived from any public assistance program. (Not all prohibited bases apply to all programs.) Persons with disabilities who require

alternative means for communication of program information (Braille, large print, audiotape, etc.) should contact USDA's TARGET Center at (202) 720-2600 (voice and TDD). To file a complaint of discrimination, write to USDA, Director, Office of Civil Rights, 1400 Independence Avenue, S.W., Washington, D.C. 20250-9410 or call (800) 795-3272 (voice) or (202) 720-6382 (TDD). USDA is an equal opportunity provider and employer.

# How Soil Surveys Are Made

---

Soil surveys are made to provide information about the soils and miscellaneous areas in a specific area. They include a description of the soils and miscellaneous areas and their location on the landscape and tables that show soil properties and limitations affecting various uses. Soil scientists observed the steepness, length, and shape of the slopes; the general pattern of drainage; the kinds of crops and native plants; and the kinds of bedrock. They observed and described many soil profiles. A soil profile is the sequence of natural layers, or horizons, in a soil. The profile extends from the surface down into the unconsolidated material in which the soil formed or from the surface down to bedrock. The unconsolidated material is devoid of roots and other living organisms and has not been changed by other biological activity.

Currently, soils are mapped according to the boundaries of major land resource areas (MLRAs). MLRAs are geographically associated land resource units that share common characteristics related to physiography, geology, climate, water resources, soils, biological resources, and land uses (USDA, 2006). Soil survey areas typically consist of parts of one or more MLRA.

The soils and miscellaneous areas in a survey area occur in an orderly pattern that is related to the geology, landforms, relief, climate, and natural vegetation of the area. Each kind of soil and miscellaneous area is associated with a particular kind of landform or with a segment of the landform. By observing the soils and miscellaneous areas in the survey area and relating their position to specific segments of the landform, a soil scientist develops a concept, or model, of how they were formed. Thus, during mapping, this model enables the soil scientist to predict with a considerable degree of accuracy the kind of soil or miscellaneous area at a specific location on the landscape.

Commonly, individual soils on the landscape merge into one another as their characteristics gradually change. To construct an accurate soil map, however, soil scientists must determine the boundaries between the soils. They can observe only a limited number of soil profiles. Nevertheless, these observations, supplemented by an understanding of the soil-vegetation-landscape relationship, are sufficient to verify predictions of the kinds of soil in an area and to determine the boundaries.

Soil scientists recorded the characteristics of the soil profiles that they studied. They noted soil color, texture, size and shape of soil aggregates, kind and amount of rock fragments, distribution of plant roots, reaction, and other features that enable them to identify soils. After describing the soils in the survey area and determining their properties, the soil scientists assigned the soils to taxonomic classes (units). Taxonomic classes are concepts. Each taxonomic class has a set of soil characteristics with precisely defined limits. The classes are used as a basis for comparison to classify soils systematically. Soil taxonomy, the system of taxonomic classification used in the United States, is based mainly on the kind and character of soil properties and the arrangement of horizons within the profile. After the soil

## Custom Soil Resource Report

scientists classified and named the soils in the survey area, they compared the individual soils with similar soils in the same taxonomic class in other areas so that they could confirm data and assemble additional data based on experience and research.

The objective of soil mapping is not to delineate pure map unit components; the objective is to separate the landscape into landforms or landform segments that have similar use and management requirements. Each map unit is defined by a unique combination of soil components and/or miscellaneous areas in predictable proportions. Some components may be highly contrasting to the other components of the map unit. The presence of minor components in a map unit in no way diminishes the usefulness or accuracy of the data. The delineation of such landforms and landform segments on the map provides sufficient information for the development of resource plans. If intensive use of small areas is planned, onsite investigation is needed to define and locate the soils and miscellaneous areas.

Soil scientists make many field observations in the process of producing a soil map. The frequency of observation is dependent upon several factors, including scale of mapping, intensity of mapping, design of map units, complexity of the landscape, and experience of the soil scientist. Observations are made to test and refine the soil-landscape model and predictions and to verify the classification of the soils at specific locations. Once the soil-landscape model is refined, a significantly smaller number of measurements of individual soil properties are made and recorded. These measurements may include field measurements, such as those for color, depth to bedrock, and texture, and laboratory measurements, such as those for content of sand, silt, clay, salt, and other components. Properties of each soil typically vary from one point to another across the landscape.

Observations for map unit components are aggregated to develop ranges of characteristics for the components. The aggregated values are presented. Direct measurements do not exist for every property presented for every map unit component. Values for some properties are estimated from combinations of other properties.

While a soil survey is in progress, samples of some of the soils in the area generally are collected for laboratory analyses and for engineering tests. Soil scientists interpret the data from these analyses and tests as well as the field-observed characteristics and the soil properties to determine the expected behavior of the soils under different uses. Interpretations for all of the soils are field tested through observation of the soils in different uses and under different levels of management. Some interpretations are modified to fit local conditions, and some new interpretations are developed to meet local needs. Data are assembled from other sources, such as research information, production records, and field experience of specialists. For example, data on crop yields under defined levels of management are assembled from farm records and from field or plot experiments on the same kinds of soil.

Predictions about soil behavior are based not only on soil properties but also on such variables as climate and biological activity. Soil conditions are predictable over long periods of time, but they are not predictable from year to year. For example, soil scientists can predict with a fairly high degree of accuracy that a given soil will have a high water table within certain depths in most years, but they cannot predict that a high water table will always be at a specific level in the soil on a specific date.

After soil scientists located and identified the significant natural bodies of soil in the survey area, they drew the boundaries of these bodies on aerial photographs and

## Custom Soil Resource Report

identified each as a specific map unit. Aerial photographs show trees, buildings, fields, roads, and rivers, all of which help in locating boundaries accurately.

# Soil Map

---

The soil map section includes the soil map for the defined area of interest, a list of soil map units on the map and extent of each map unit, and cartographic symbols displayed on the map. Also presented are various metadata about data used to produce the map, and a description of each soil map unit.

Hydrologic Soil Group—Fairfield County, South Carolina  
(Overall Area 20210225)

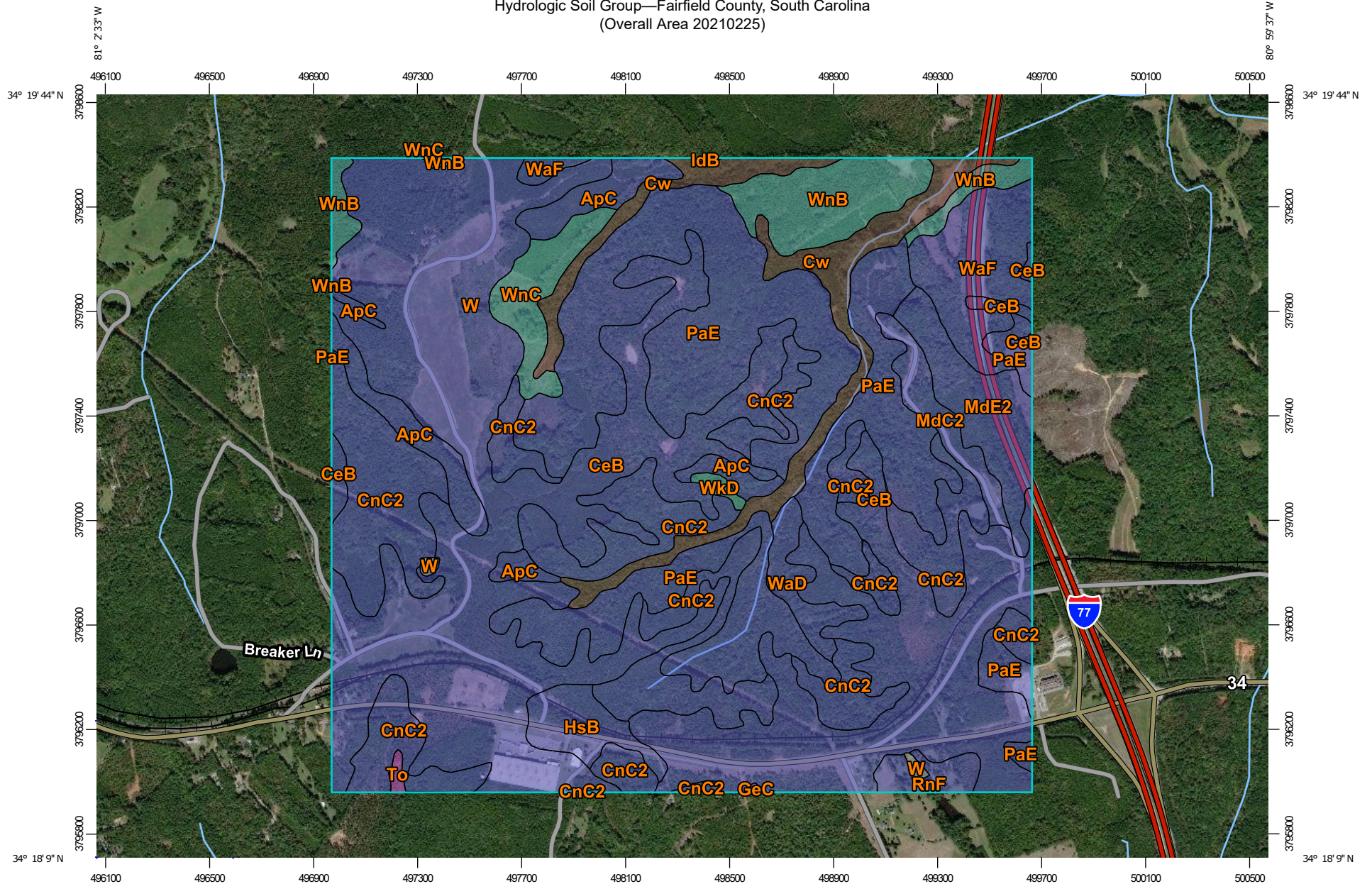

Map Scale: 1:20,600 if printed on A landscape (11" x 8.5") sheet.

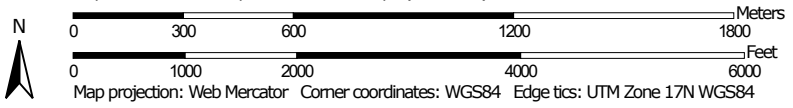

Map projection: Web Mercator Corner coordinates: WGS84 Edge tics: UTM Zone 17N WGS84



## MAP LEGEND

### Area of Interest (AOI)









 Area of Interest (AOI)

### Soils

#### Soil Rating Polygons





 A  
 A/D  
 B  
 B/D  
 C  
 C/D  
 D  
 Not rated or not available

#### Soil Rating Lines

 A  
 A/D  
 B  
 B/D  
 C  
 C/D  
 D  
 Not rated or not available

#### Soil Rating Points





 A  
 A/D  
 B  
 B/D

 C  
 C/D  
 D  
 Not rated or not available

### Water Features

 Streams and Canals

### Transportation

 Rails  
 Interstate Highways  
 US Routes  
 Major Roads  
 Local Roads

### Background

 Aerial Photography

## MAP INFORMATION

The soil surveys that comprise your AOI were mapped at 1:20,000.

Please rely on the bar scale on each map sheet for map measurements.

Source of Map: Natural Resources Conservation Service  
 Web Soil Survey URL:  
 Coordinate System: Web Mercator (EPSG:3857)

Maps from the Web Soil Survey are based on the Web Mercator projection, which preserves direction and shape but distorts distance and area. A projection that preserves area, such as the Albers equal-area conic projection, should be used if more accurate calculations of distance or area are required.

This product is generated from the USDA-NRCS certified data as of the version date(s) listed below.

Soil Survey Area: Fairfield County, South Carolina  
 Survey Area Data: Version 15, Jun 3, 2020

Soil map units are labeled (as space allows) for map scales 1:50,000 or larger.

Date(s) aerial images were photographed: Apr 23, 2014—Oct 2, 2017

The orthophoto or other base map on which the soil lines were compiled and digitized probably differs from the background imagery displayed on these maps. As a result, some minor shifting of map unit boundaries may be evident.

## Hydrologic Soil Group

Map unit symbol	Map unit name	Rating	Acres in AOI	Percent of AOI
ApC	Appling loamy sand, 6 to 10 percent slopes	B	52.5	3.2%
CeB	Cecil sandy loam, 2 to 6 percent slopes	B	639.7	39.4%
CnC2	Cecil sandy clay loam, 6 to 10 percent slopes, moderately eroded	B	257.5	15.8%
Cw	Chewacla loam, 0 to 2 percent slopes, frequently flooded	B/D	75.4	4.6%
GeC	Georgeville loam, 6 to 10 percent slopes	B	0.4	0.0%
HsB	Hiwassee sandy loam, 2 to 6 percent slopes	B	23.0	1.4%
IdB	Iredell fine sandy loam, 1 to 6 percent slopes	D	0.3	0.0%
MdC2	Madison sandy clay loam, 6 to 10 percent slopes, eroded	B	19.9	1.2%
MdE2	Madison sandy clay loam, 10 to 25 percent slopes, eroded	B	43.8	2.7%
PaE	Pacolet sandy loam, 10 to 25 percent slopes	B	325.8	20.1%
RnF	Rion loamy sand, 15 to 40 percent slopes	B	12.1	0.7%
To	Toccoa loam	A	1.8	0.1%
W	Water		2.7	0.2%
WaD	Wateree-Rion complex, 6 to 15 percent slopes	B	18.4	1.1%
WaF	Wateree-Rion complex, 15 to 40 percent slopes	B	57.3	3.5%
WkD	Wilkes sandy loam, 6 to 15 percent slopes	C	2.9	0.2%
WnB	Winnsboro sandy loam, 2 to 6 percent slopes	C	62.0	3.8%
WnC	Winnsboro sandy loam, 6 to 10 percent slopes	C	29.2	1.8%
<b>Totals for Area of Interest</b>			<b>1,624.7</b>	<b>100.0%</b>

## Description

Hydrologic soil groups are based on estimates of runoff potential. Soils are assigned to one of four groups according to the rate of water infiltration when the soils are not protected by vegetation, are thoroughly wet, and receive precipitation from long-duration storms.

The soils in the United States are assigned to four groups (A, B, C, and D) and three dual classes (A/D, B/D, and C/D). The groups are defined as follows:

Group A. Soils having a high infiltration rate (low runoff potential) when thoroughly wet. These consist mainly of deep, well drained to excessively drained sands or gravelly sands. These soils have a high rate of water transmission.

Group B. Soils having a moderate infiltration rate when thoroughly wet. These consist chiefly of moderately deep or deep, moderately well drained or well drained soils that have moderately fine texture to moderately coarse texture. These soils have a moderate rate of water transmission.

Group C. Soils having a slow infiltration rate when thoroughly wet. These consist chiefly of soils having a layer that impedes the downward movement of water or soils of moderately fine texture or fine texture. These soils have a slow rate of water transmission.

Group D. Soils having a very slow infiltration rate (high runoff potential) when thoroughly wet. These consist chiefly of clays that have a high shrink-swell potential, soils that have a high water table, soils that have a claypan or clay layer at or near the surface, and soils that are shallow over nearly impervious material. These soils have a very slow rate of water transmission.

If a soil is assigned to a dual hydrologic group (A/D, B/D, or C/D), the first letter is for drained areas and the second is for undrained areas. Only the soils that in their natural condition are in group D are assigned to dual classes.

## Rating Options

*Aggregation Method:* Dominant Condition

*Component Percent Cutoff:* None Specified

*Tie-break Rule:* Higher

## **Reference 4**

*Drainage Area Figures, S&ME Inc., March 2021.*

Drawing Path: R:\CADDData\Charlotte\4261\20\LUCK STONE ALT. I-77\GIS\Export from CAD\03082021\Drainage Area Figures\Drainage Area Figures.mxd plotted by kwallace 03-22-2021

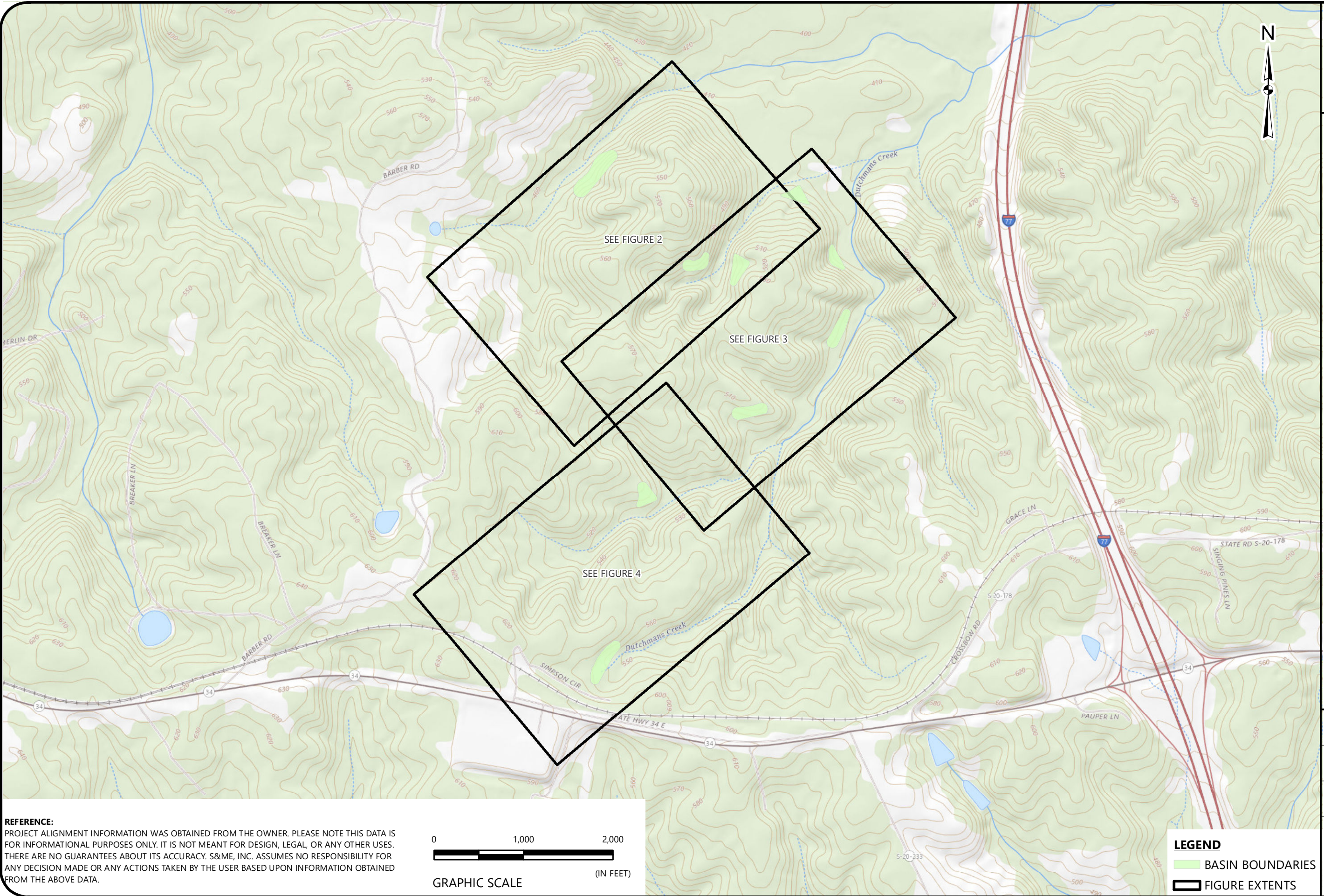

**DRAINAGE AREA FIGURES**

FAIRFIELD I-77 DEVELOPMENT SITE  
LUCK STONE CORPORATION  
FAIRFIELD COUNTY, SOUTH CAROLINA

SCALE:  
1" = 1,000'  
DATE:  
3-22-2021  
PROJECT NUMBER:  
210730C  
FIGURE NO.

**1**

**REFERENCE:**  
PROJECT ALIGNMENT INFORMATION WAS OBTAINED FROM THE OWNER. PLEASE NOTE THIS DATA IS FOR INFORMATIONAL PURPOSES ONLY. IT IS NOT MEANT FOR DESIGN, LEGAL, OR ANY OTHER USES. THERE ARE NO GUARANTEES ABOUT ITS ACCURACY. S&ME, INC. ASSUMES NO RESPONSIBILITY FOR ANY DECISION MADE OR ANY ACTIONS TAKEN BY THE USER BASED UPON INFORMATION OBTAINED FROM THE ABOVE DATA.

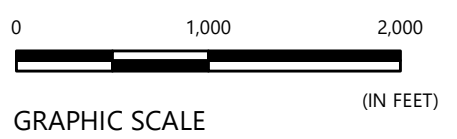

**LEGEND**  
■ BASIN BOUNDARIES  
□ FIGURE EXTENTS

Drawing Path: R:\CADDData\Charlotte\4261\20\LUCK STONE ALT. I-77\GIS\Export from CAD\03082021\Drainage Area Figures\Drainage Area Figures\K\mxd plotted by kwallace 03-22-2021

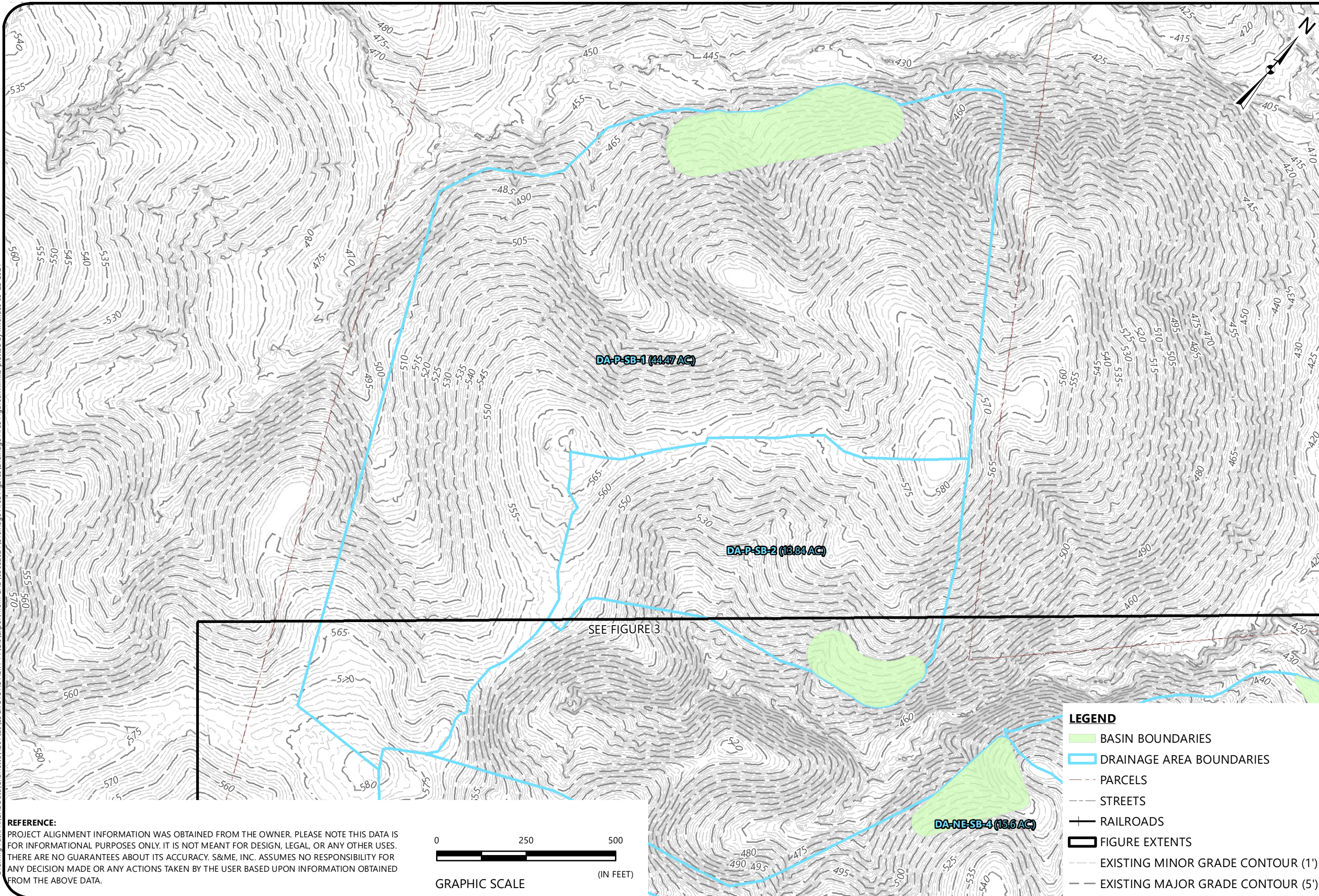

**REFERENCE:**  
PROJECT ALIGNMENT INFORMATION WAS OBTAINED FROM THE OWNER. PLEASE NOTE THIS DATA IS FOR INFORMATIONAL PURPOSES ONLY. IT IS NOT MEANT FOR DESIGN, LEGAL, OR ANY OTHER USES. THERE ARE NO GUARANTEES ABOUT ITS ACCURACY. S&ME, INC. ASSUMES NO RESPONSIBILITY FOR ANY DECISION MADE OR ANY ACTIONS TAKEN BY THE USER BASED UPON INFORMATION OBTAINED FROM THE ABOVE DATA.



**LEGEND**

- BASIN BOUNDARIES
- DRAINAGE AREA BOUNDARIES
- PARCELS
- STREETS
- RAILROADS
- FIGURE EXTENTS
- EXISTING MINOR GRADE CONTOUR (1')
- EXISTING MAJOR GRADE CONTOUR (5')



**DRAINAGE AREA FIGURES**

FAIRFIELD I-77 DEVELOPMENT SITE  
LUCK STONE CORPORATION  
FAIRFIELD COUNTY, SOUTH CAROLINA

SCALE:  
1" = 250'

DATE:  
3-22-2021

PROJECT NUMBER:  
210730C

FIGURE NO.

**2**



Drawing Path: R:\CADData\Charlotte\4261\20\LUCK STONE ALT. I-77\GIS\Export from CAD\03082021\Drainage Area Figures\Drainage Area Figures\KW.mxd, plotted by kwallace 03-22-2021

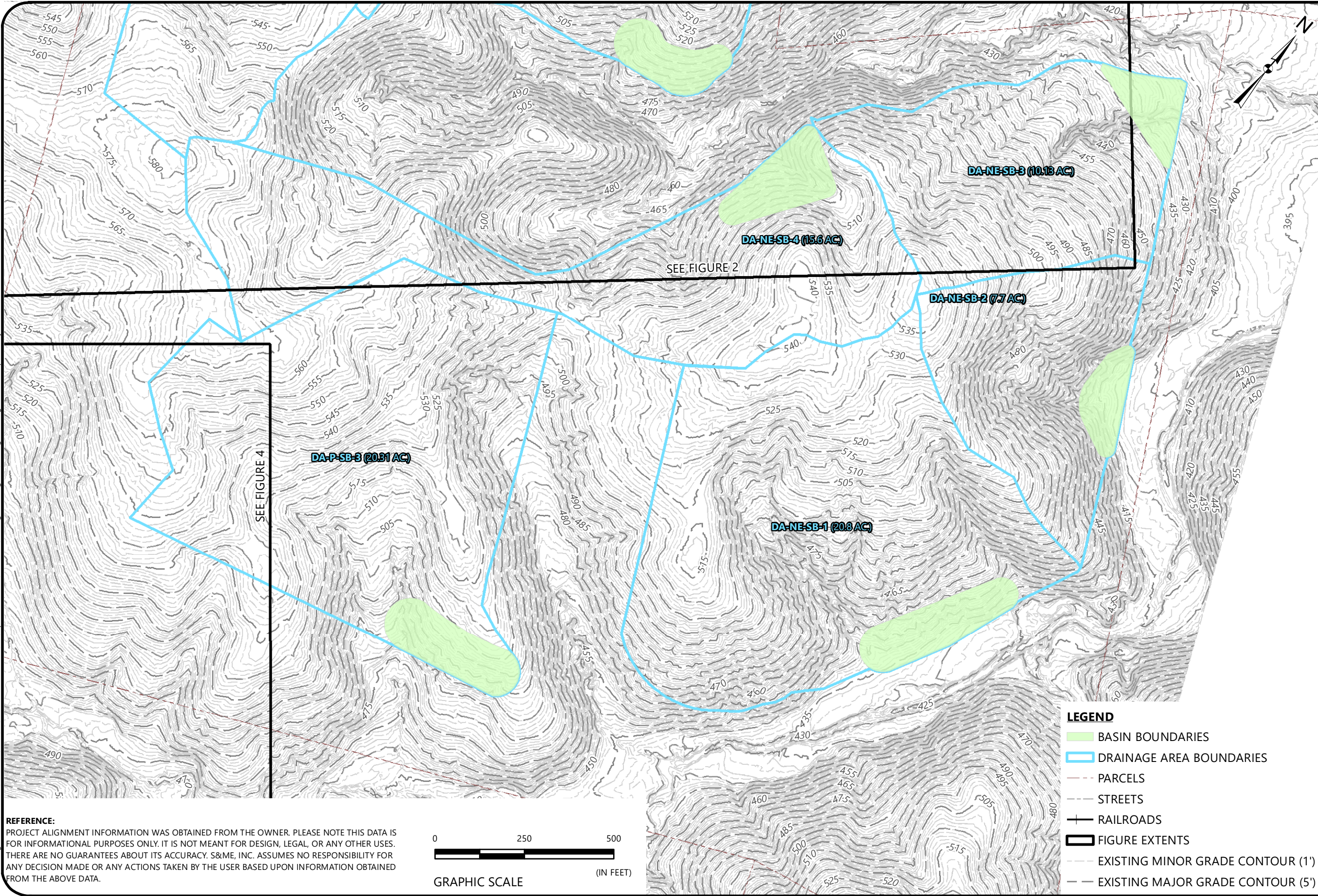

**DRAINAGE AREA FIGURES**

FAIRFIELD I-77 DEVELOPMENT SITE  
LUCK STONE CORPORATION  
FAIRFIELD COUNTY, SOUTH CAROLINA

**REFERENCE:**  
PROJECT ALIGNMENT INFORMATION WAS OBTAINED FROM THE OWNER. PLEASE NOTE THIS DATA IS FOR INFORMATIONAL PURPOSES ONLY. IT IS NOT MEANT FOR DESIGN, LEGAL, OR ANY OTHER USES. THERE ARE NO GUARANTEES ABOUT ITS ACCURACY. S&ME, INC. ASSUMES NO RESPONSIBILITY FOR ANY DECISION MADE OR ANY ACTIONS TAKEN BY THE USER BASED UPON INFORMATION OBTAINED FROM THE ABOVE DATA.



LEGEND	
	BASIN BOUNDARIES
	DRAINAGE AREA BOUNDARIES
	PARCELS
	STREETS
	RAILROADS
	FIGURE EXTENTS
	EXISTING MINOR GRADE CONTOUR (1')
	EXISTING MAJOR GRADE CONTOUR (5')

SCALE:  
1" = 250'

DATE:  
3-22-2021

PROJECT NUMBER:  
210730C

FIGURE NO.

**3**

Drawing Path: R:\CADDData\Charlotte\4261\20\LUCK STONE ALT. I-77\GIS\Export from CAD\03082021\Drainage Area Figures\Drainage Area Figures\K\mxd, plotted by kwallace 03-22-2021

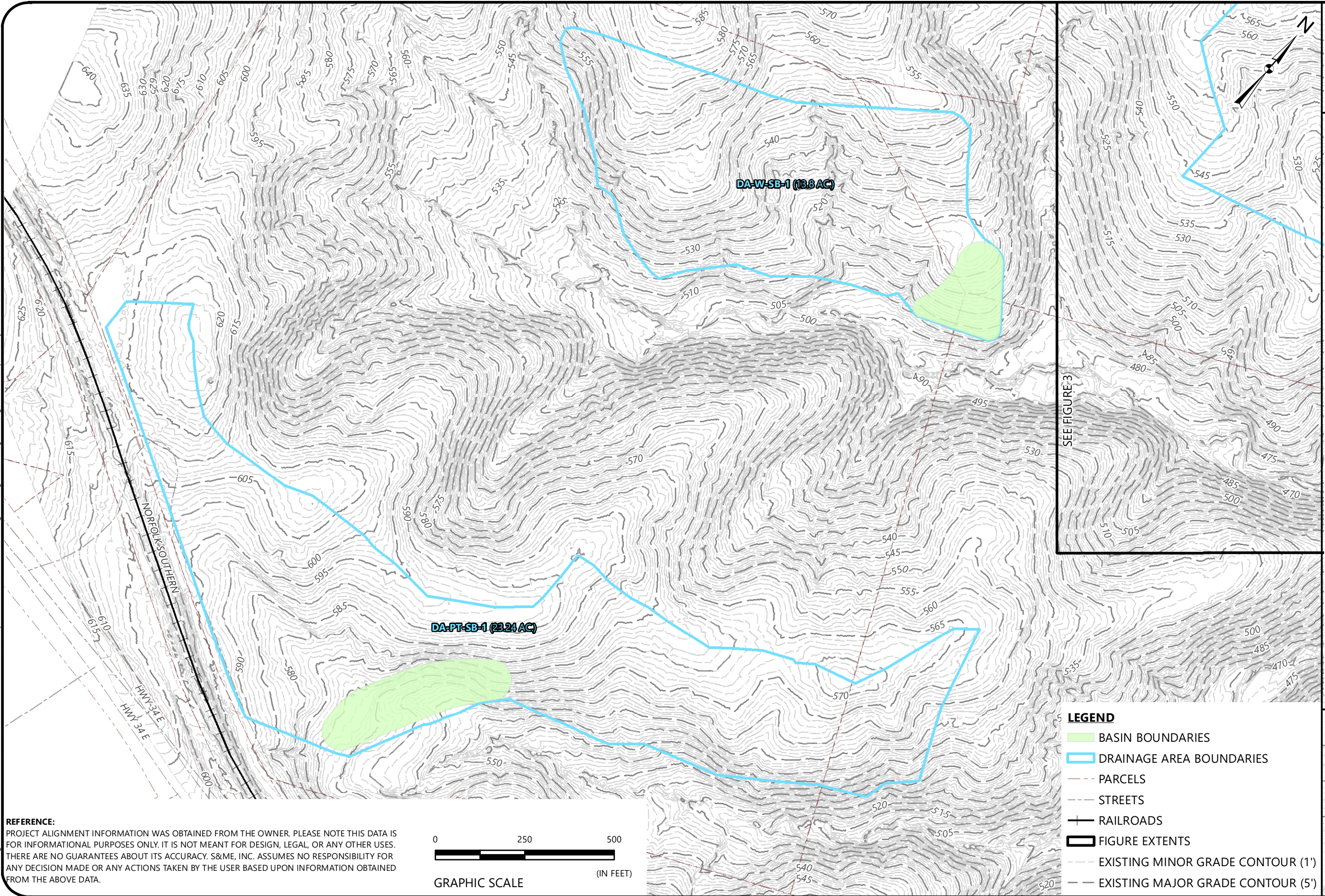

**REFERENCE:**  
PROJECT ALIGNMENT INFORMATION WAS OBTAINED FROM THE OWNER. PLEASE NOTE THIS DATA IS FOR INFORMATIONAL PURPOSES ONLY. IT IS NOT MEANT FOR DESIGN, LEGAL, OR ANY OTHER USES. THERE ARE NO GUARANTEES ABOUT ITS ACCURACY. S&M, INC. ASSUMES NO RESPONSIBILITY FOR ANY DECISION MADE OR ANY ACTIONS TAKEN BY THE USER BASED UPON INFORMATION OBTAINED FROM THE ABOVE DATA.

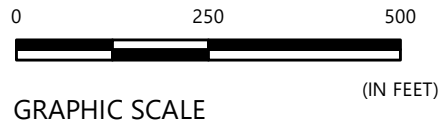

- LEGEND**
- BASIN BOUNDARIES
  - DRAINAGE AREA BOUNDARIES
  - PARCELS
  - STREETS
  - RAILROADS
  - FIGURE EXTENTS
  - EXISTING MINOR GRADE CONTOUR (1')
  - EXISTING MAJOR GRADE CONTOUR (5')



**DRAINAGE AREA FIGURES**

FAIRFIELD I-77 DEVELOPMENT SITE  
LUCK STONE CORPORATION  
FAIRFIELD COUNTY, SOUTH CAROLINA

SCALE:  
1" = 250'

DATE:  
3-22-2021

PROJECT NUMBER:  
210730C

FIGURE NO.

**4**



## **Reference 5**

*Compiled HydroCAD Report, S&ME Inc., March 2021.*



PT-SB-1

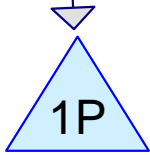

P-PT-SB-1



W-SB-1

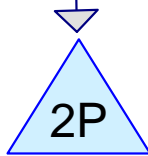

P-W-SB-1

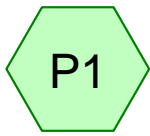

P-SB-1

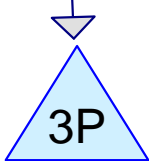

P-P-SB-1

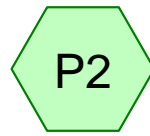

P-SB-2

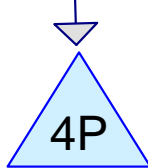

P-P-SB-2

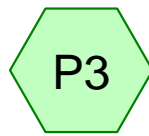

P-SB-3

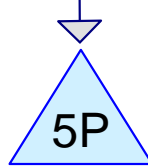

P-P-SB-3

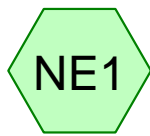

NE-SB-1

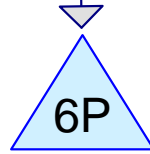

P-NE-SB-1



NE-SB-2

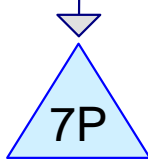

P-NE-SB-2

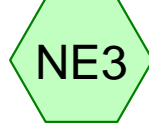

NE-SB-3

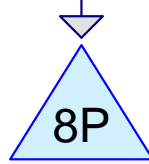

P-NE-SB-3

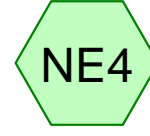

NE-SB-4

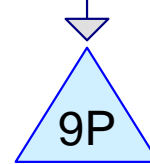

P-NE-SB-4

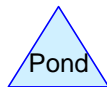
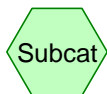

## **210730C\_I77\_SEDIMENT\_BASINS**

Prepared by S&ME, Inc.

HydroCAD® 10.00-26 s/n 06707 © 2020 HydroCAD Software Solutions LLC

Printed 3/18/2021

Page 2

---

### **Project Notes**

Defined 10 rainfall events from NOAA\_I77\_LUCKSTONE IDF

## 210730C\_I77\_SEDIMENT\_BASINS

Prepared by S&ME, Inc.

HydroCAD® 10.00-26 s/n 06707 © 2020 HydroCAD Software Solutions LLC

Printed 3/18/2021

Page 3

### Area Listing (all nodes)

Area (acres)	CN	Description (subcatchment-numbers)
169.825	94	Newly graded area, HSG D (NE1, NE2, NE3, NE4, P1, P2, P3, PT1, W1)
<b>169.825</b>	<b>94</b>	<b>TOTAL AREA</b>

# 210730C\_I77\_SEDIMENT\_BASINS

Prepared by S&ME, Inc.

HydroCAD® 10.00-26 s/n 06707 © 2020 HydroCAD Software Solutions LLC

Printed 3/18/2021

Page 4

## Soil Listing (all nodes)

Area (acres)	Soil Group	Subcatchment Numbers
0.000	HSG A	
0.000	HSG B	
0.000	HSG C	
169.825	HSG D	NE1, NE2, NE3, NE4, P1, P2, P3, PT1, W1
0.000	Other	
<b>169.825</b>		<b>TOTAL AREA</b>

## 210730C\_I77\_SEDIMENT\_BASINS

Prepared by S&ME, Inc.

HydroCAD® 10.00-26 s/n 06707 © 2020 HydroCAD Software Solutions LLC

Printed 3/18/2021

Page 5

### Ground Covers (all nodes)

HSG-A (acres)	HSG-B (acres)	HSG-C (acres)	HSG-D (acres)	Other (acres)	Total (acres)	Ground Cover	Subcatchment Numbers
0.000	0.000	0.000	169.825	0.000	169.825	Newly graded area	NE1, NE2, NE3, NE4, P1, P2, P3, PT1, W1
<b>0.000</b>	<b>0.000</b>	<b>0.000</b>	<b>169.825</b>	<b>0.000</b>	<b>169.825</b>	<b>TOTAL AREA</b>	

## 210730C\_I77\_SEDIMENT\_BASINS

Prepared by S&ME, Inc.

HydroCAD® 10.00-26 s/n 06707 © 2020 HydroCAD Software Solutions LLC

Printed 3/18/2021

Page 6

### Pipe Listing (all nodes)

Line#	Node Number	In-Invert (feet)	Out-Invert (feet)	Length (feet)	Slope (ft/ft)	n	Diam/Width (inches)	Height (inches)	Inside-Fill (inches)
1	1P	557.00	556.00	100.0	0.0100	0.012	24.0	0.0	0.0
2	2P	500.00	499.00	100.0	0.0100	0.012	24.0	0.0	0.0
3	3P	450.00	449.00	100.0	0.0100	0.012	24.0	0.0	0.0
4	4P	481.00	480.00	100.0	0.0100	0.012	24.0	0.0	0.0
5	5P	490.00	489.00	100.0	0.0100	0.012	24.0	0.0	0.0
6	6P	427.00	426.00	100.0	0.0100	0.012	24.0	0.0	0.0
7	7P	412.00	411.00	100.0	0.0100	0.012	24.0	0.0	0.0
8	8P	412.00	411.00	100.0	0.0100	0.012	24.0	0.0	0.0
9	9P	479.00	478.00	100.0	0.0100	0.012	24.0	0.0	0.0

**210730C\_I77\_SEDIMENT\_BASINS**

Type II 24-hr 2-yr Rainfall=3.54"

Prepared by S&amp;ME, Inc.

Printed 3/18/2021

HydroCAD® 10.00-26 s/n 06707 © 2020 HydroCAD Software Solutions LLC

Page 7

Time span=5.00-20.00 hrs, dt=0.05 hrs, 301 points  
 Runoff by SCS TR-20 method, UH=SCS, Weighted-CN  
 Reach routing by Stor-Ind+Trans method - Pond routing by Stor-Ind method

<b>Subcatchment NE1: NE-SB-1</b>	Runoff Area=906,076 sf 0.00% Impervious Runoff Depth>2.69" Flow Length=990' Tc=9.9 min CN=94 Runoff=84.97 cfs 4.668 af
<b>Subcatchment NE2: NE-SB-2</b>	Runoff Area=334,011 sf 0.00% Impervious Runoff Depth>2.70" Flow Length=640' Tc=6.4 min CN=94 Runoff=34.49 cfs 1.722 af
<b>Subcatchment NE3: NE-SB-3</b>	Runoff Area=441,198 sf 0.00% Impervious Runoff Depth>2.69" Flow Length=840' Tc=7.1 min CN=94 Runoff=45.15 cfs 2.274 af
<b>Subcatchment NE4: NE-SB-4</b>	Runoff Area=679,173 sf 0.00% Impervious Runoff Depth>2.69" Flow Length=1,778' Tc=8.5 min CN=94 Runoff=66.78 cfs 3.500 af
<b>Subcatchment P1: P-SB-1</b>	Runoff Area=1,936,988 sf 0.00% Impervious Runoff Depth>2.69" Flow Length=1,935' Tc=14.1 min CN=94 Runoff=159.90 cfs 9.971 af
<b>Subcatchment P2: P-SB-2</b>	Runoff Area=603,049 sf 0.00% Impervious Runoff Depth>2.69" Flow Length=1,182' Tc=8.5 min CN=94 Runoff=59.30 cfs 3.108 af
<b>Subcatchment P3: P-SB-3</b>	Runoff Area=884,859 sf 0.00% Impervious Runoff Depth>2.69" Flow Length=1,112' Tc=9.2 min CN=94 Runoff=85.00 cfs 4.560 af
<b>Subcatchment PT1: PT-SB-1</b>	Runoff Area=1,012,355 sf 0.00% Impervious Runoff Depth>2.69" Flow Length=1,104' Tc=11.5 min CN=94 Runoff=90.21 cfs 5.214 af
<b>Subcatchment W1: W-SB-1</b>	Runoff Area=599,872 sf 0.00% Impervious Runoff Depth>2.69" Flow Length=1,193' Tc=7.9 min CN=94 Runoff=60.08 cfs 3.092 af
<b>Pond 1P: P-PT-SB-1</b>	Peak Elev=560.71' Storage=183,037 cf Inflow=90.21 cfs 5.214 af Primary=1.17 cfs 1.014 af Secondary=0.00 cfs 0.000 af Outflow=1.17 cfs 1.014 af
<b>Pond 2P: P-W-SB-1</b>	Peak Elev=503.48' Storage=101,288 cf Inflow=60.08 cfs 3.092 af Primary=0.89 cfs 0.790 af Secondary=0.00 cfs 0.000 af Outflow=0.89 cfs 0.790 af
<b>Pond 3P: P-P-SB-1</b>	Peak Elev=454.83' Storage=347,855 cf Inflow=159.90 cfs 9.971 af Primary=2.34 cfs 1.993 af Secondary=0.00 cfs 0.000 af Outflow=2.34 cfs 1.993 af
<b>Pond 4P: P-P-SB-2</b>	Peak Elev=485.21' Storage=100,616 cf Inflow=59.30 cfs 3.108 af Primary=0.89 cfs 0.821 af Secondary=0.00 cfs 0.000 af Outflow=0.89 cfs 0.821 af
<b>Pond 5P: P-P-SB-3</b>	Peak Elev=494.84' Storage=152,378 cf Inflow=85.00 cfs 4.560 af Primary=1.17 cfs 1.074 af Secondary=0.00 cfs 0.000 af Outflow=1.17 cfs 1.074 af
<b>Pond 6P: P-NE-SB-1</b>	Peak Elev=431.93' Storage=156,699 cf Inflow=84.97 cfs 4.668 af Primary=1.17 cfs 1.081 af Secondary=0.00 cfs 0.000 af Outflow=1.17 cfs 1.081 af
<b>Pond 7P: P-NE-SB-2</b>	Peak Elev=415.11' Storage=51,963 cf Inflow=34.49 cfs 1.722 af Primary=0.66 cfs 0.587 af Secondary=0.00 cfs 0.000 af Outflow=0.66 cfs 0.587 af



**210730C\_I77\_SEDIMENT\_BASINS**

Type II 24-hr 2-yr Rainfall=3.54"

Prepared by S&ME, Inc.

Printed 3/18/2021

HydroCAD® 10.00-26 s/n 06707 © 2020 HydroCAD Software Solutions LLC

Page 8

**Pond 8P: P-NE-SB-3**

Peak Elev=415.98' Storage=73,062 cf Inflow=45.15 cfs 2.274 af  
Primary=0.66 cfs 0.615 af Secondary=0.00 cfs 0.000 af Outflow=0.66 cfs 0.615 af

**Pond 9P: P-NE-SB-4**

Peak Elev=482.49' Storage=111,255 cf Inflow=66.78 cfs 3.500 af  
Primary=1.17 cfs 1.008 af Secondary=0.00 cfs 0.000 af Outflow=1.17 cfs 1.008 af

**Total Runoff Area = 169.825 ac Runoff Volume = 38.110 af Average Runoff Depth = 2.69"**  
**100.00% Pervious = 169.825 ac 0.00% Impervious = 0.000 ac**

**210730C\_I77\_SEDIMENT\_BASINS**

Prepared by S&ME, Inc.

HydroCAD® 10.00-26 s/n 06707 © 2020 HydroCAD Software Solutions LLC

Type II 24-hr 2-yr Rainfall=3.54"

Printed 3/18/2021

Page 9

**Summary for Subcatchment NE1: NE-SB-1**

Runoff = 84.97 cfs @ 12.01 hrs, Volume= 4.668 af, Depth> 2.69"

Runoff by SCS TR-20 method, UH=SCS, Weighted-CN, Time Span= 5.00-20.00 hrs, dt= 0.05 hrs  
 Type II 24-hr 2-yr Rainfall=3.54"

Area (sf)	CN	Description
906,076	94	Newly graded area, HSG D
906,076		100.00% Pervious Area

Tc (min)	Length (feet)	Slope (ft/ft)	Velocity (ft/sec)	Capacity (cfs)	Description
6.7	300	0.0464	0.75		<b>Sheet Flow,</b> Fallow n= 0.050 P2= 3.54"
3.2	690	0.1262	3.55		<b>Shallow Concentrated Flow,</b> Nearly Bare & Untilled Kv= 10.0 fps
9.9	990	Total			

**Subcatchment NE1: NE-SB-1**

Hydrograph

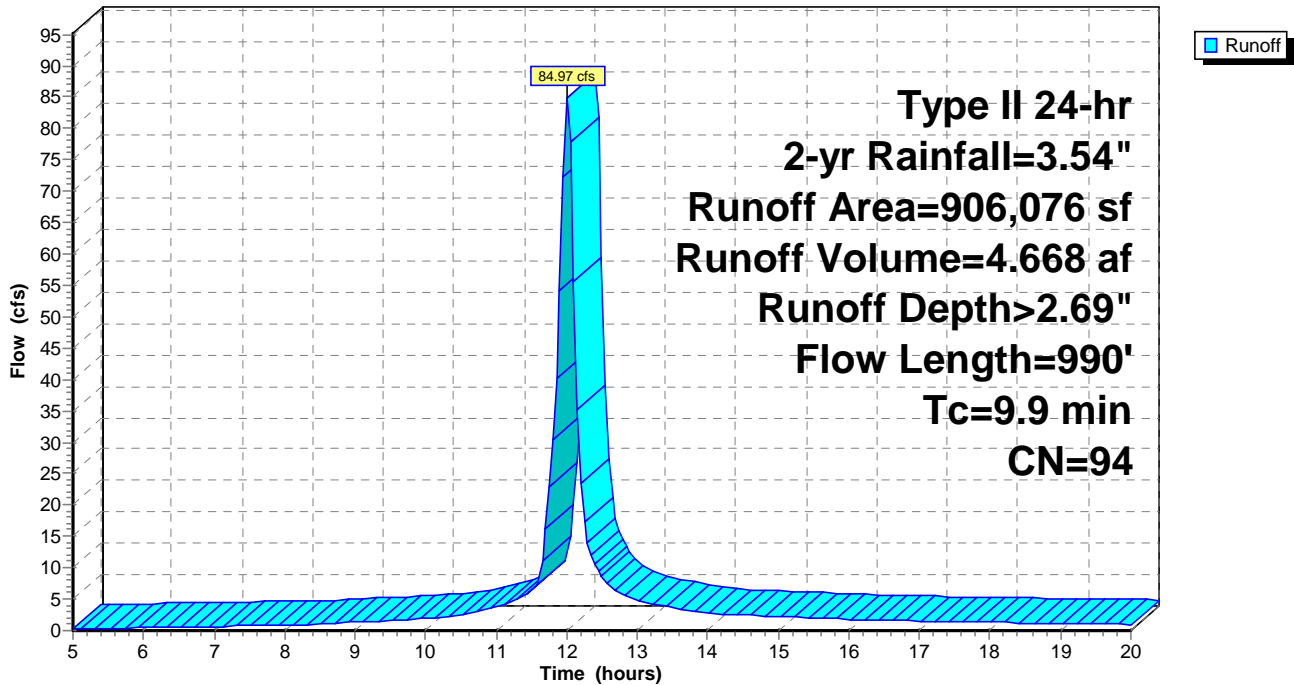

**210730C\_I77\_SEDIMENT\_BASINS**

Prepared by S&ME, Inc.

HydroCAD® 10.00-26 s/n 06707 © 2020 HydroCAD Software Solutions LLC

Type II 24-hr 2-yr Rainfall=3.54"

Printed 3/18/2021

Page 10

**Summary for Subcatchment NE2: NE-SB-2**

No Channel Flow

Runoff = 34.49 cfs @ 11.97 hrs, Volume= 1.722 af, Depth> 2.70"

Runoff by SCS TR-20 method, UH=SCS, Weighted-CN, Time Span= 5.00-20.00 hrs, dt= 0.05 hrs  
Type II 24-hr 2-yr Rainfall=3.54"

Area (sf)	CN	Description
334,011	94	Newly graded area, HSG D
334,011		100.00% Pervious Area

Tc (min)	Length (feet)	Slope (ft/ft)	Velocity (ft/sec)	Capacity (cfs)	Description
5.3	300	0.0812	0.94		<b>Sheet Flow,</b> Fallow n= 0.050 P2= 3.54"
1.1	340	0.2754	5.25		<b>Shallow Concentrated Flow,</b> Nearly Bare & Untilled Kv= 10.0 fps
6.4	640	Total			

**Subcatchment NE2: NE-SB-2**

Hydrograph

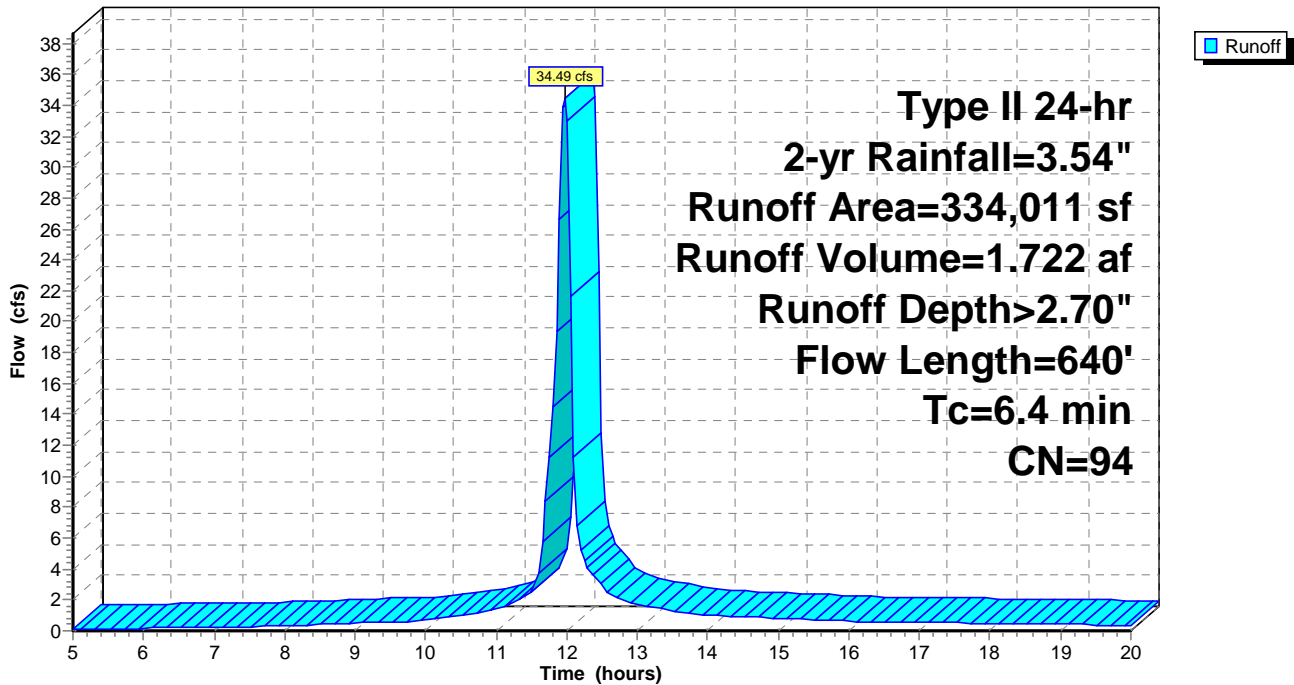

**210730C\_I77\_SEDIMENT\_BASINS**

Prepared by S&ME, Inc.

HydroCAD® 10.00-26 s/n 06707 © 2020 HydroCAD Software Solutions LLC

Type II 24-hr 2-yr Rainfall=3.54"

Printed 3/18/2021

Page 11

**Summary for Subcatchment NE3: NE-SB-3**

No Channel Flow

Runoff = 45.15 cfs @ 11.98 hrs, Volume= 2.274 af, Depth> 2.69"

Runoff by SCS TR-20 method, UH=SCS, Weighted-CN, Time Span= 5.00-20.00 hrs, dt= 0.05 hrs  
Type II 24-hr 2-yr Rainfall=3.54"

Area (sf)	CN	Description
441,198	94	Newly graded area, HSG D
441,198		100.00% Pervious Area

Tc (min)	Length (feet)	Slope (ft/ft)	Velocity (ft/sec)	Capacity (cfs)	Description
4.8	300	0.1075	1.05		<b>Sheet Flow,</b> Fallow n= 0.050 P2= 3.54"
2.3	540	0.1570	3.96		<b>Shallow Concentrated Flow,</b> Nearly Bare & Untilled Kv= 10.0 fps
7.1	840	Total			

**Subcatchment NE3: NE-SB-3**

Hydrograph

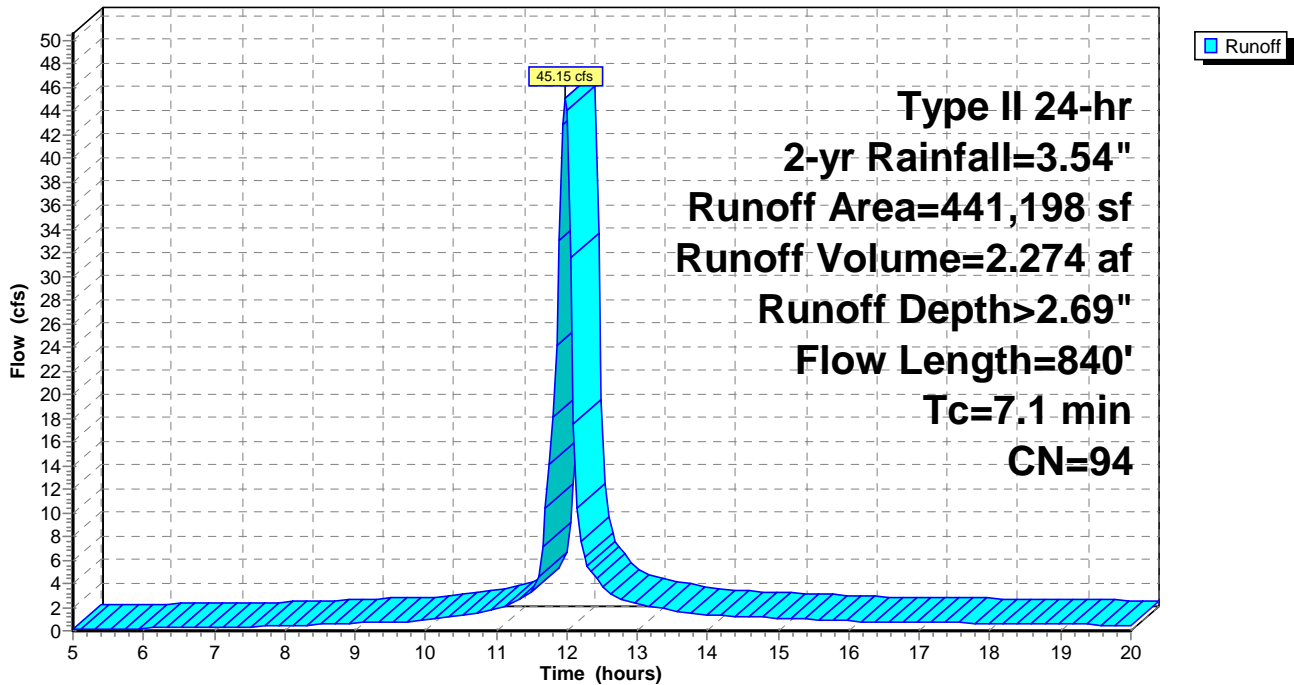

**210730C\_I77\_SEDIMENT\_BASINS**

Prepared by S&ME, Inc.

HydroCAD® 10.00-26 s/n 06707 © 2020 HydroCAD Software Solutions LLC

Type II 24-hr 2-yr Rainfall=3.54"

Printed 3/18/2021

Page 12

**Summary for Subcatchment NE4: NE-SB-4**

No Channel Flow

Runoff = 66.78 cfs @ 11.99 hrs, Volume= 3.500 af, Depth> 2.69"

Runoff by SCS TR-20 method, UH=SCS, Weighted-CN, Time Span= 5.00-20.00 hrs, dt= 0.05 hrs  
Type II 24-hr 2-yr Rainfall=3.54"

Area (sf)	CN	Description
679,173	94	Newly graded area, HSG D
679,173		100.00% Pervious Area

Tc (min)	Length (feet)	Slope (ft/ft)	Velocity (ft/sec)	Capacity (cfs)	Description
5.6	300	0.0719	0.90		<b>Sheet Flow,</b> Fallow n= 0.050 P2= 3.54"
1.8	290	0.0706	2.66		<b>Shallow Concentrated Flow,</b> Nearly Bare & Untilled Kv= 10.0 fps
1.1	1,188	0.0328	17.76	621.77	<b>Channel Flow,</b> Area= 35.0 sf Perim= 20.0' r= 1.75' n= 0.022 Earth, clean & straight
8.5	1,778	Total			

**Subcatchment NE4: NE-SB-4**

Hydrograph

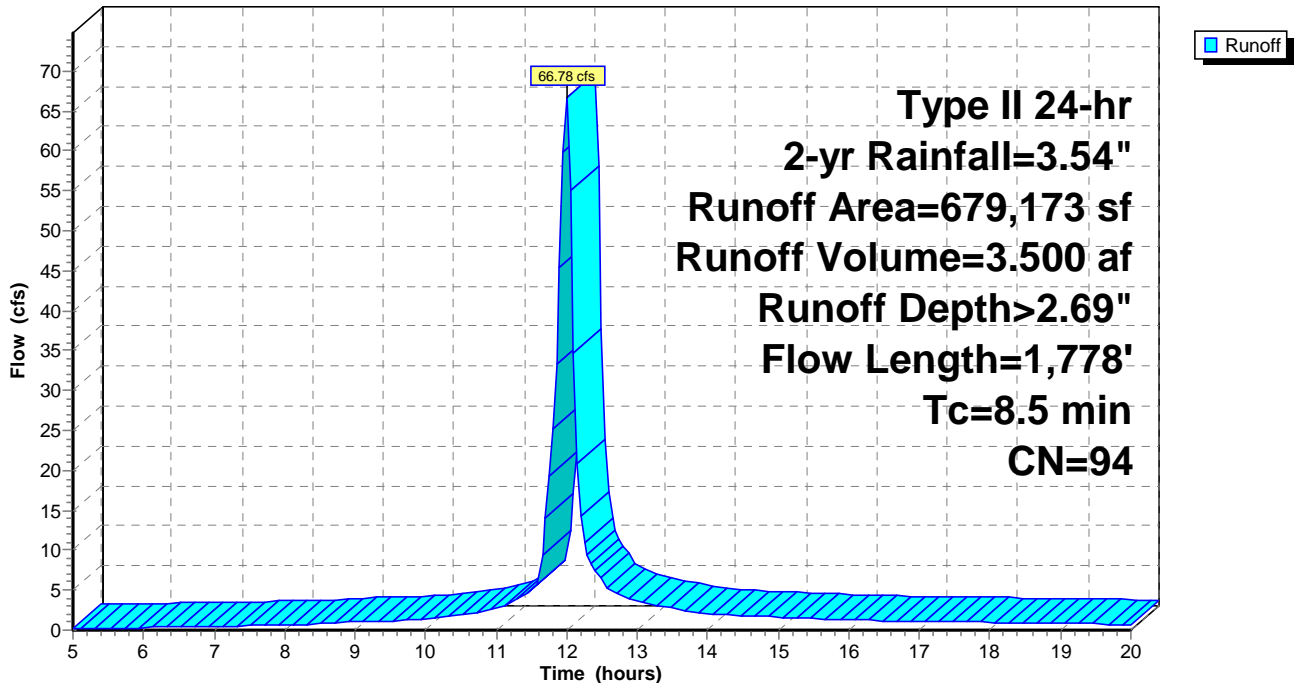

**210730C\_I77\_SEDIMENT\_BASINS**

Prepared by S&ME, Inc.

HydroCAD® 10.00-26 s/n 06707 © 2020 HydroCAD Software Solutions LLC

Type II 24-hr 2-yr Rainfall=3.54"

Printed 3/18/2021

Page 13

**Summary for Subcatchment P1: P-SB-1**

No Channel Flow

Runoff = 159.90 cfs @ 12.05 hrs, Volume= 9.971 af, Depth> 2.69"

Runoff by SCS TR-20 method, UH=SCS, Weighted-CN, Time Span= 5.00-20.00 hrs, dt= 0.05 hrs  
Type II 24-hr 2-yr Rainfall=3.54"

Area (sf)	CN	Description
1,936,988	94	Newly graded area, HSG D
1,936,988		100.00% Pervious Area

Tc (min)	Length (feet)	Slope (ft/ft)	Velocity (ft/sec)	Capacity (cfs)	Description
5.3	300	0.0838	0.95		<b>Sheet Flow,</b> Fallow n= 0.050 P2= 3.54"
7.9	1,294	0.0737	2.71		<b>Shallow Concentrated Flow,</b> Nearly Bare & Untilled Kv= 10.0 fps
0.9	341	0.0045	6.58	230.30	<b>Channel Flow,</b> Area= 35.0 sf Perim= 20.0' r= 1.75' n= 0.022 Earth, clean & straight
14.1	1,935	Total			

**Subcatchment P1: P-SB-1**

Hydrograph

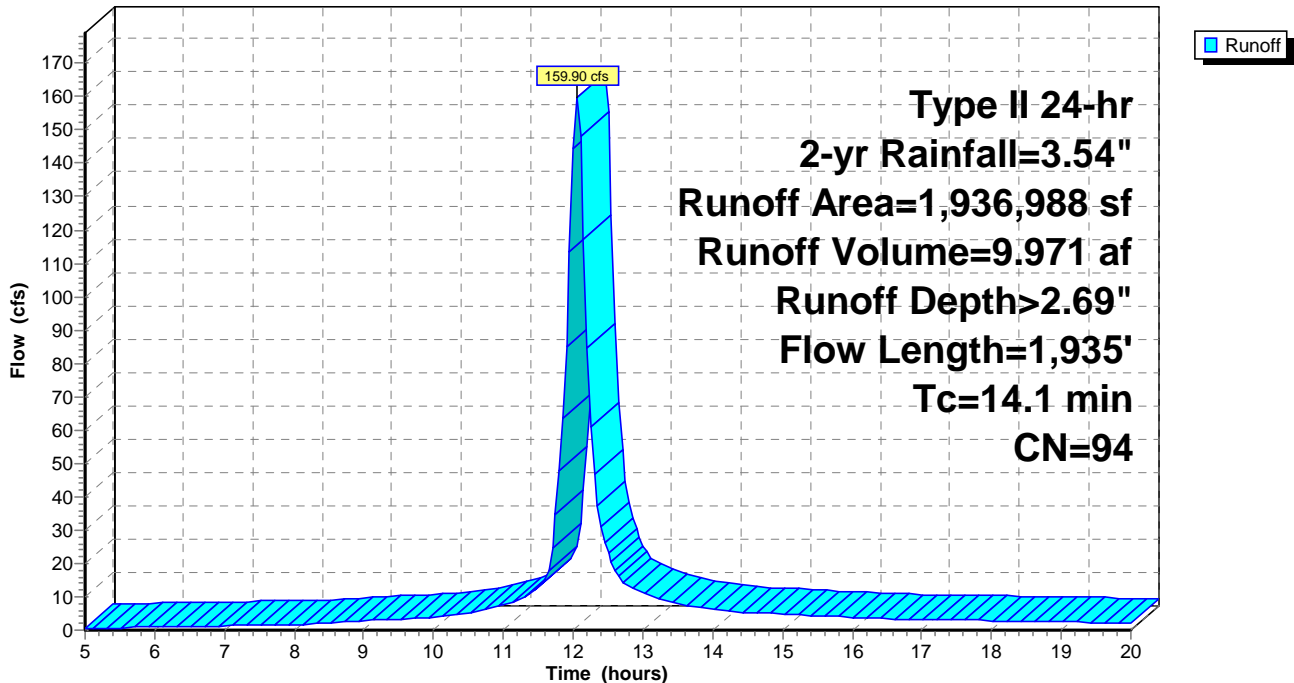

**210730C\_I77\_SEDIMENT\_BASINS**

Prepared by S&ME, Inc.

HydroCAD® 10.00-26 s/n 06707 © 2020 HydroCAD Software Solutions LLC

Type II 24-hr 2-yr Rainfall=3.54"

Printed 3/18/2021

Page 14

**Summary for Subcatchment P2: P-SB-2**

No Channel Flow

Runoff = 59.30 cfs @ 11.99 hrs, Volume= 3.108 af, Depth> 2.69"

Runoff by SCS TR-20 method, UH=SCS, Weighted-CN, Time Span= 5.00-20.00 hrs, dt= 0.05 hrs  
Type II 24-hr 2-yr Rainfall=3.54"

Area (sf)	CN	Description
603,049	94	Newly graded area, HSG D
603,049		100.00% Pervious Area

Tc (min)	Length (feet)	Slope (ft/ft)	Velocity (ft/sec)	Capacity (cfs)	Description
5.2	300	0.0842	0.95		<b>Sheet Flow,</b> Fallow n= 0.050 P2= 3.54"
3.0	582	0.1023	3.20		<b>Shallow Concentrated Flow,</b> Nearly Bare & Untilled Kv= 10.0 fps
0.3	300	0.0240	15.20	531.86	<b>Channel Flow,</b> Area= 35.0 sf Perim= 20.0' r= 1.75' n= 0.022 Earth, clean & straight

8.5 1,182 Total

**Subcatchment P2: P-SB-2**

Hydrograph

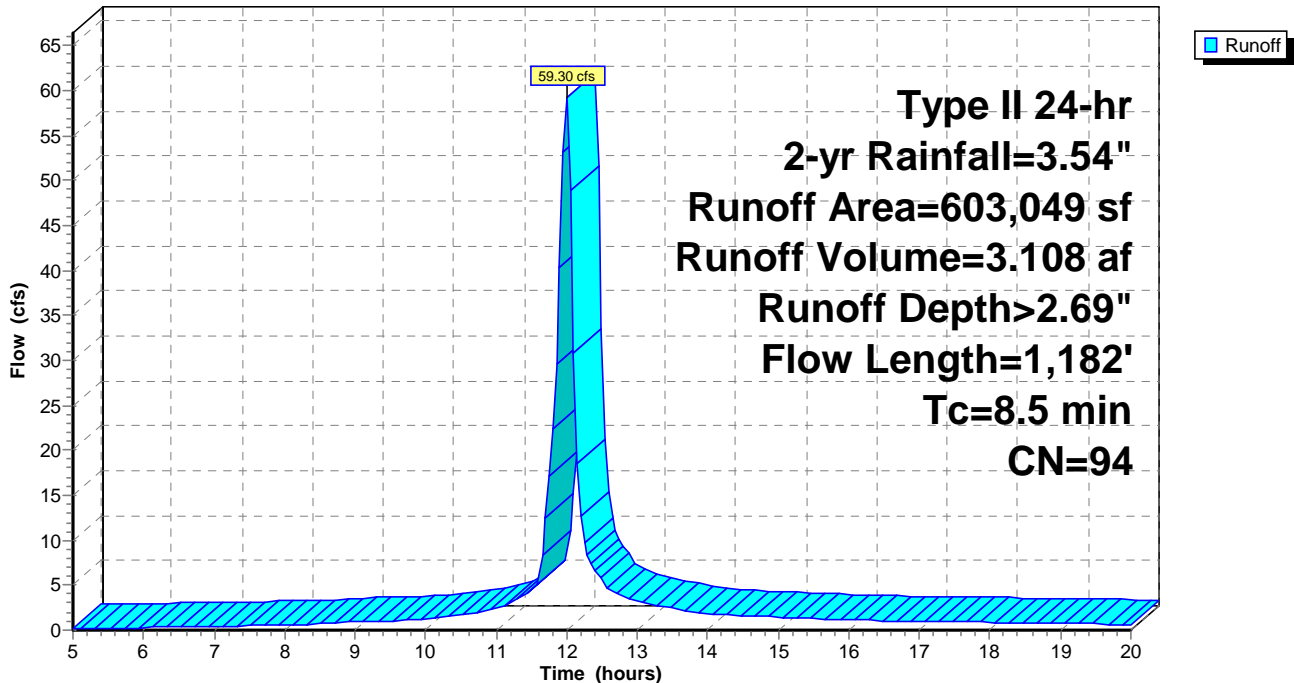

**210730C\_I77\_SEDIMENT\_BASINS**

Prepared by S&ME, Inc.

HydroCAD® 10.00-26 s/n 06707 © 2020 HydroCAD Software Solutions LLC

Type II 24-hr 2-yr Rainfall=3.54"

Printed 3/18/2021

Page 15

**Summary for Subcatchment P3: P-SB-3**

Runoff = 85.00 cfs @ 12.00 hrs, Volume= 4.560 af, Depth> 2.69"

Runoff by SCS TR-20 method, UH=SCS, Weighted-CN, Time Span= 5.00-20.00 hrs, dt= 0.05 hrs  
 Type II 24-hr 2-yr Rainfall=3.54"

Area (sf)	CN	Description
884,859	94	Newly graded area, HSG D
884,859		100.00% Pervious Area

Tc (min)	Length (feet)	Slope (ft/ft)	Velocity (ft/sec)	Capacity (cfs)	Description
4.7	300	0.1095	1.06		<b>Sheet Flow,</b> Fallow n= 0.050 P2= 3.54"
4.3	699	0.0738	2.72		<b>Shallow Concentrated Flow,</b> Nearly Bare & Untilled Kv= 10.0 fps
0.2	113	0.0088	9.20	322.06	<b>Channel Flow,</b> Area= 35.0 sf Perim= 20.0' r= 1.75' n= 0.022 Earth, clean & straight
9.2	1,112	Total			

**Subcatchment P3: P-SB-3**

Hydrograph

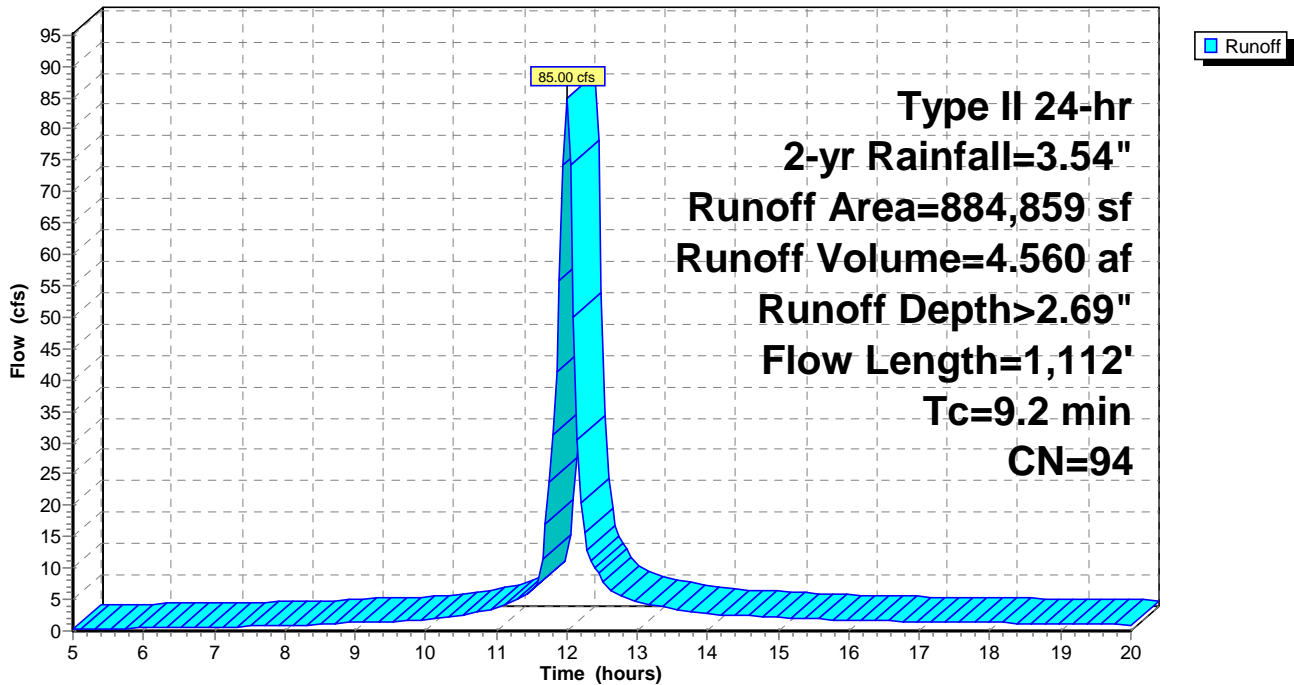



**210730C\_I77\_SEDIMENT\_BASINS**

Prepared by S&ME, Inc.

HydroCAD® 10.00-26 s/n 06707 © 2020 HydroCAD Software Solutions LLC

Type II 24-hr 2-yr Rainfall=3.54"

Printed 3/18/2021

Page 16

**Summary for Subcatchment PT1: PT-SB-1**

No Channel Flow

Runoff = 90.21 cfs @ 12.03 hrs, Volume= 5.214 af, Depth> 2.69"

Runoff by SCS TR-20 method, UH=SCS, Weighted-CN, Time Span= 5.00-20.00 hrs, dt= 0.05 hrs  
Type II 24-hr 2-yr Rainfall=3.54"

Area (sf)	CN	Description
1,012,355	94	Newly graded area, HSG D
1,012,355		100.00% Pervious Area

Tc (min)	Length (feet)	Slope (ft/ft)	Velocity (ft/sec)	Capacity (cfs)	Description
6.2	300	0.0546	0.80		<b>Sheet Flow,</b> Fallow n= 0.050 P2= 3.54"
5.3	804	0.0630	2.51		<b>Shallow Concentrated Flow,</b> Nearly Bare & Untilled Kv= 10.0 fps
11.5	1,104	Total			

**Subcatchment PT1: PT-SB-1**

Hydrograph

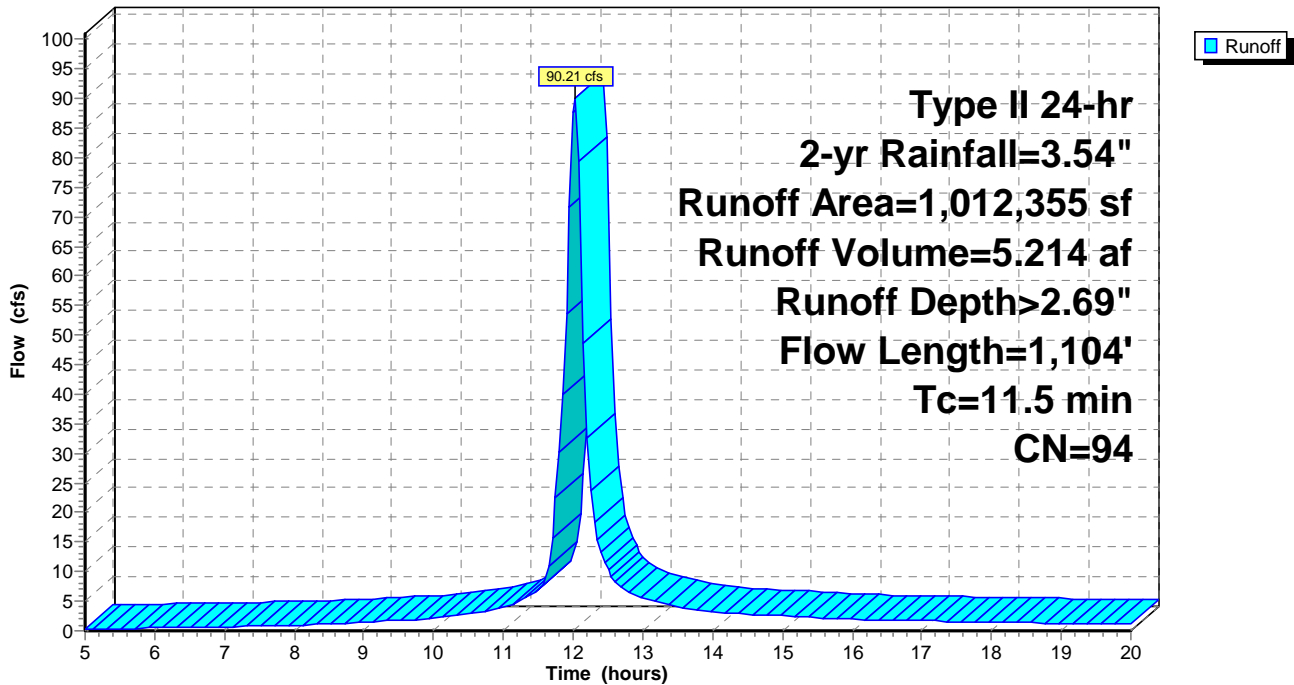

**210730C\_I77\_SEDIMENT\_BASINS**

Prepared by S&ME, Inc.

HydroCAD® 10.00-26 s/n 06707 © 2020 HydroCAD Software Solutions LLC

Type II 24-hr 2-yr Rainfall=3.54"

Printed 3/18/2021

Page 17

**Summary for Subcatchment W1: W-SB-1**

Runoff = 60.08 cfs @ 11.99 hrs, Volume= 3.092 af, Depth> 2.69"

Runoff by SCS TR-20 method, UH=SCS, Weighted-CN, Time Span= 5.00-20.00 hrs, dt= 0.05 hrs  
 Type II 24-hr 2-yr Rainfall=3.54"

Area (sf)	CN	Description
599,872	94	Newly graded area, HSG D
599,872		100.00% Pervious Area

Tc (min)	Length (feet)	Slope (ft/ft)	Velocity (ft/sec)	Capacity (cfs)	Description
5.6	300	0.0707	0.89		<b>Sheet Flow,</b> Fallow n= 0.050 P2= 3.54"
1.6	334	0.1196	3.46		<b>Shallow Concentrated Flow,</b> Nearly Bare & Untilled Kv= 10.0 fps
0.7	559	0.0190	13.52	473.22	<b>Channel Flow,</b> Area= 35.0 sf Perim= 20.0' r= 1.75' n= 0.022 Earth, clean & straight
7.9	1,193	Total			

**Subcatchment W1: W-SB-1**

Hydrograph

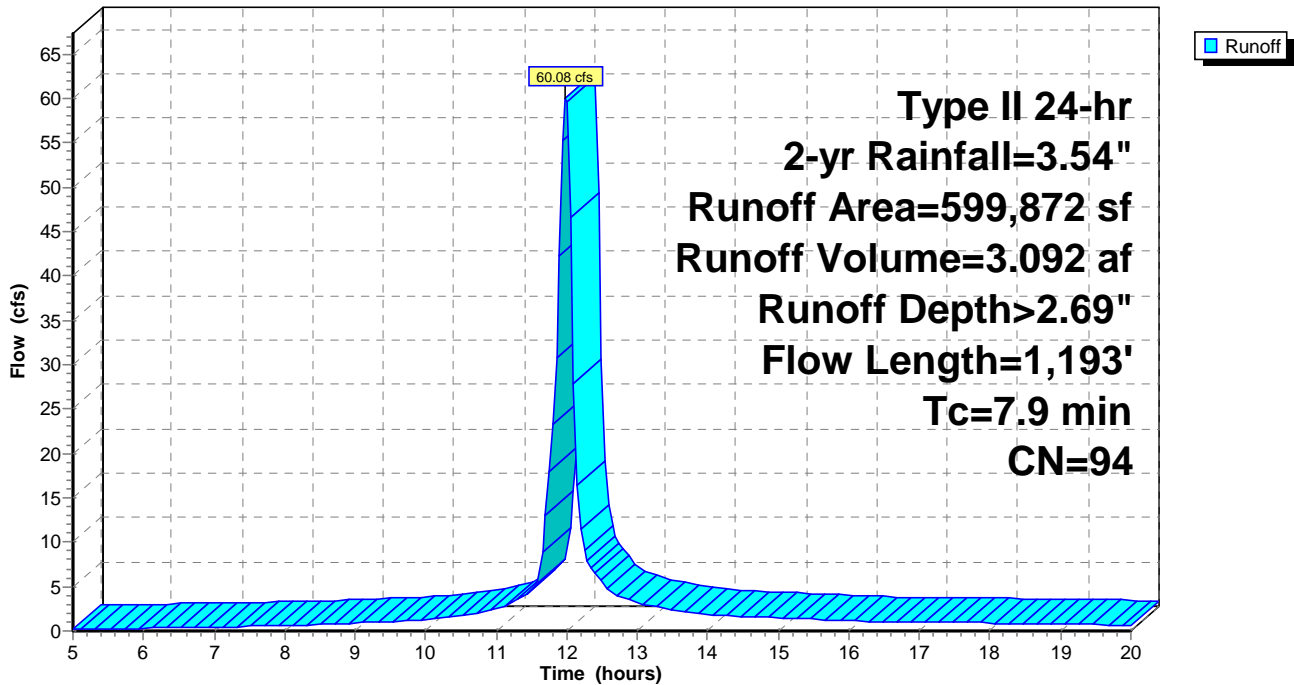

**210730C\_I77\_SEDIMENT\_BASINS**

Type II 24-hr 2-yr Rainfall=3.54"

Prepared by S&ME, Inc.

Printed 3/18/2021

HydroCAD® 10.00-26 s/n 06707 © 2020 HydroCAD Software Solutions LLC

Page 18

**Summary for Pond 1P: P-PT-SB-1**

[82] Warning: Early inflow requires earlier time span

Inflow Area = 23.240 ac, 0.00% Impervious, Inflow Depth > 2.69" for 2-yr event  
 Inflow = 90.21 cfs @ 12.03 hrs, Volume= 5.214 af  
 Outflow = 1.17 cfs @ 11.00 hrs, Volume= 1.014 af, Atten= 99%, Lag= 0.0 min  
 Primary = 1.17 cfs @ 11.00 hrs, Volume= 1.014 af  
 Secondary = 0.00 cfs @ 5.00 hrs, Volume= 0.000 af

Routing by Stor-Ind method, Time Span= 5.00-20.00 hrs, dt= 0.05 hrs  
 Peak Elev= 560.71' @ 19.59 hrs Surf.Area= 55,901 sf Storage= 183,037 cf

Plug-Flow detention time= 284.3 min calculated for 1.013 af (19% of inflow)  
 Center-of-Mass det. time= 129.5 min ( 882.6 - 753.1 )

Volume	Invert	Avail.Storage	Storage Description
#1	557.00'	455,428 cf	<b>Custom Stage Data (Prismatic)</b> Listed below (Recalc)

Elevation (feet)	Surf.Area (sq-ft)	Inc.Store (cubic-feet)	Cum.Store (cubic-feet)
557.00	42,794	0	0
565.00	71,063	455,428	455,428

Device	Routing	Invert	Outlet Devices
#1	Device 2	557.00'	<b>1.168 cfs Constant Flow/Skimmer</b>
#2	Primary	557.00'	<b>24.0" Round Culvert</b> L= 100.0' CMP, square edge headwall, Ke= 0.500 Inlet / Outlet Invert= 557.00' / 556.00' S= 0.0100 '/' Cc= 0.900 n= 0.012 Concrete pipe, finished, Flow Area= 3.14 sf
#3	Device 2	562.70'	<b>36.0" x 36.0" Horiz. Orifice/Grate</b> C= 0.600 Limited to weir flow at low heads
#4	Secondary	563.70'	<b>20.0' long x 12.0' breadth Broad-Crested Rectangular Weir</b> Head (feet) 0.20 0.40 0.60 0.80 1.00 1.20 1.40 1.60 Coef. (English) 2.57 2.62 2.70 2.67 2.66 2.67 2.66 2.64

**Primary OutFlow** Max=1.17 cfs @ 11.00 hrs HW=557.49' (Free Discharge)  
 ↑ **2=Culvert** (Passes 1.17 cfs of 1.42 cfs potential flow)  
 ↑ **1=Constant Flow/Skimmer** (Constant Controls 1.17 cfs)  
 ↑ **3=Orifice/Grate** ( Controls 0.00 cfs)

**Secondary OutFlow** Max=0.00 cfs @ 5.00 hrs HW=557.00' (Free Discharge)  
 ↑ **4=Broad-Crested Rectangular Weir** ( Controls 0.00 cfs)

**210730C\_I77\_SEDIMENT\_BASINS**

Prepared by S&ME, Inc.

HydroCAD® 10.00-26 s/n 06707 © 2020 HydroCAD Software Solutions LLC

Type II 24-hr 2-yr Rainfall=3.54"

Printed 3/18/2021

Page 19

**Pond 1P: P-PT-SB-1**

Hydrograph

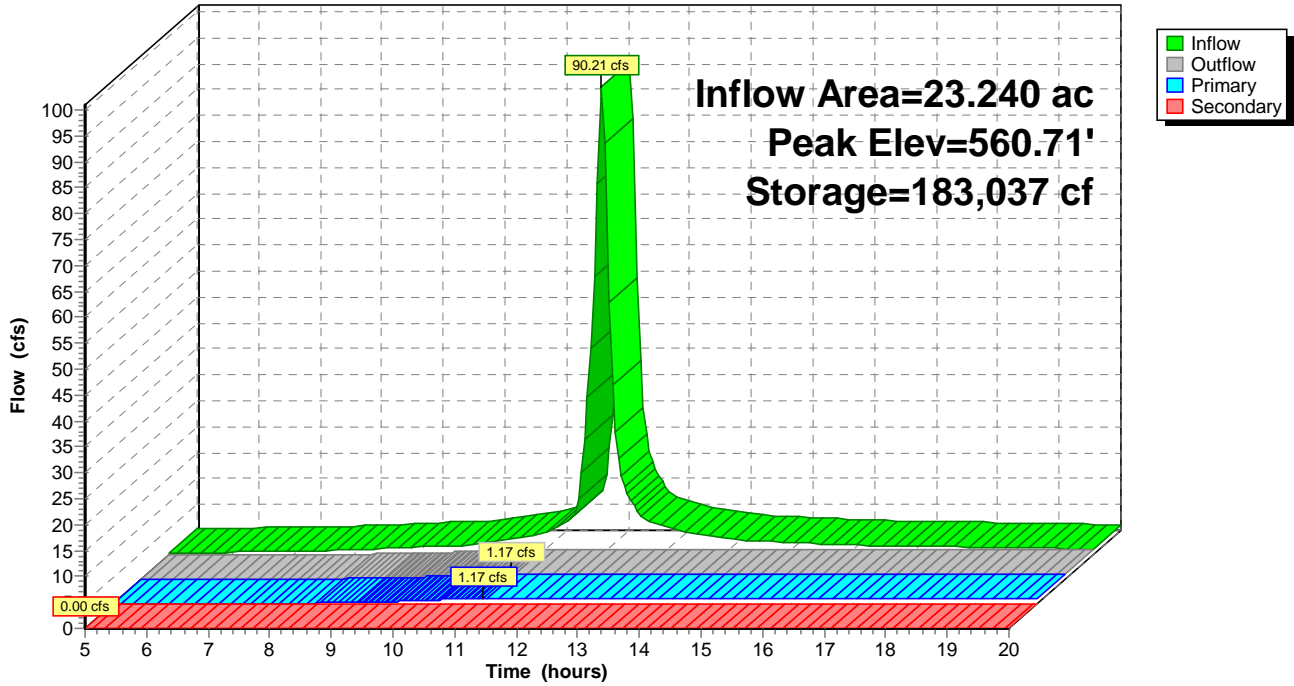

**210730C\_I77\_SEDIMENT\_BASINS**

Prepared by S&ME, Inc.

HydroCAD® 10.00-26 s/n 06707 © 2020 HydroCAD Software Solutions LLC

Type II 24-hr 2-yr Rainfall=3.54"

Printed 3/18/2021

Page 20

**Summary for Pond 2P: P-W-SB-1**

[82] Warning: Early inflow requires earlier time span

Inflow Area = 13.771 ac, 0.00% Impervious, Inflow Depth > 2.69" for 2-yr event  
 Inflow = 60.08 cfs @ 11.99 hrs, Volume= 3.092 af  
 Outflow = 0.89 cfs @ 10.80 hrs, Volume= 0.790 af, Atten= 99%, Lag= 0.0 min  
 Primary = 0.89 cfs @ 10.80 hrs, Volume= 0.790 af  
 Secondary = 0.00 cfs @ 5.00 hrs, Volume= 0.000 af

Routing by Stor-Ind method, Time Span= 5.00-20.00 hrs, dt= 0.05 hrs  
 Peak Elev= 503.48' @ 17.83 hrs Surf.Area= 33,139 sf Storage= 101,288 cf

Plug-Flow detention time= 254.1 min calculated for 0.787 af (25% of inflow)  
 Center-of-Mass det. time= 126.3 min ( 876.7 - 750.3 )

Volume	Invert	Avail.Storage	Storage Description
#1	500.00'	274,756 cf	<b>Custom Stage Data (Prismatic)</b> Listed below (Recalc)

Elevation (feet)	Surf.Area (sq-ft)	Inc.Store (cubic-feet)	Cum.Store (cubic-feet)
500.00	25,066	0	0
508.00	43,623	274,756	274,756

Device	Routing	Invert	Outlet Devices
#1	Device 2	500.00'	<b>0.894 cfs Constant Flow/Skimmer</b>
#2	Primary	500.00'	<b>24.0" Round Culvert</b> L= 100.0' CMP, square edge headwall, Ke= 0.500 Inlet / Outlet Invert= 500.00' / 499.00' S= 0.0100 '/' Cc= 0.900 n= 0.012 Concrete pipe, finished, Flow Area= 3.14 sf
#3	Device 2	505.40'	<b>36.0" x 36.0" Horiz. Orifice/Grate</b> C= 0.600 Limited to weir flow at low heads
#4	Secondary	506.40'	<b>20.0' long x 12.0' breadth Broad-Crested Rectangular Weir</b> Head (feet) 0.20 0.40 0.60 0.80 1.00 1.20 1.40 1.60 Coef. (English) 2.57 2.62 2.70 2.67 2.66 2.67 2.66 2.64

**Primary OutFlow** Max=0.89 cfs @ 10.80 hrs HW=500.41' (Free Discharge)  
 ↑ **2=Culvert** (Passes 0.89 cfs of 0.99 cfs potential flow)  
 ↑ **1=Constant Flow/Skimmer** (Constant Controls 0.89 cfs)  
 ↑ **3=Orifice/Grate** ( Controls 0.00 cfs)

**Secondary OutFlow** Max=0.00 cfs @ 5.00 hrs HW=500.00' (Free Discharge)  
 ↑ **4=Broad-Crested Rectangular Weir** ( Controls 0.00 cfs)

Pond 2P: P-W-SB-1

Hydrograph

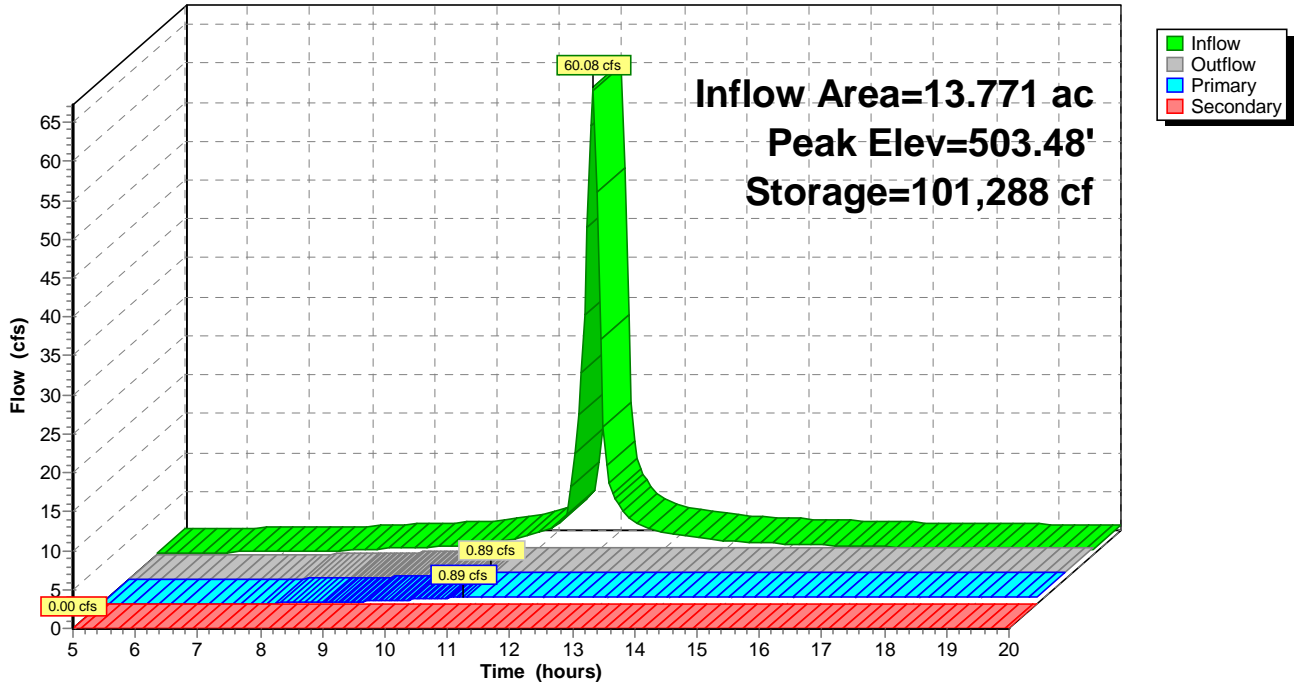

**210730C\_I77\_SEDIMENT\_BASINS**

Type II 24-hr 2-yr Rainfall=3.54"

Prepared by S&ME, Inc.

Printed 3/18/2021

HydroCAD® 10.00-26 s/n 06707 © 2020 HydroCAD Software Solutions LLC

Page 22

**Summary for Pond 3P: P-P-SB-1**

[82] Warning: Early inflow requires earlier time span

Inflow Area = 44.467 ac, 0.00% Impervious, Inflow Depth > 2.69" for 2-yr event  
 Inflow = 159.90 cfs @ 12.05 hrs, Volume= 9.971 af  
 Outflow = 2.34 cfs @ 11.20 hrs, Volume= 1.993 af, Atten= 99%, Lag= 0.0 min  
 Primary = 2.34 cfs @ 11.20 hrs, Volume= 1.993 af  
 Secondary = 0.00 cfs @ 5.00 hrs, Volume= 0.000 af

Routing by Stor-Ind method, Time Span= 5.00-20.00 hrs, dt= 0.05 hrs  
 Peak Elev= 454.83' @ 19.36 hrs Surf.Area= 82,510 sf Storage= 347,855 cf

Plug-Flow detention time= 284.1 min calculated for 1.985 af (20% of inflow)  
 Center-of-Mass det. time= 132.8 min ( 887.9 - 755.1 )

Volume	Invert	Avail.Storage	Storage Description
#1	450.00'	832,615 cf	<b>Custom Stage Data (Prismatic)</b> Listed below (Recalc)

Elevation (feet)	Surf.Area (sq-ft)	Inc.Store (cubic-feet)	Cum.Store (cubic-feet)
450.00	61,641	0	0
460.00	104,882	832,615	832,615

Device	Routing	Invert	Outlet Devices
#1	Device 2	450.00'	<b>1.168 cfs Constant Flow/Skimmer X 2.00</b>
#2	Primary	450.00'	<b>24.0" Round Culvert</b> L= 100.0' CMP, square edge headwall, Ke= 0.500 Inlet / Outlet Invert= 450.00' / 449.00' S= 0.0100 '/' Cc= 0.900 n= 0.012 Concrete pipe, finished, Flow Area= 3.14 sf
#3	Device 2	457.40'	<b>36.0" x 36.0" Horiz. Orifice/Grate</b> C= 0.600 Limited to weir flow at low heads
#4	Secondary	458.40'	<b>20.0' long x 12.0' breadth Broad-Crested Rectangular Weir</b> Head (feet) 0.20 0.40 0.60 0.80 1.00 1.20 1.40 1.60 Coef. (English) 2.57 2.62 2.70 2.67 2.66 2.67 2.66 2.64

**Primary OutFlow** Max=2.34 cfs @ 11.20 hrs HW=450.71' (Free Discharge)  
 ↑ **2=Culvert** (Passes 2.34 cfs of 2.90 cfs potential flow)  
 ↑ **1=Constant Flow/Skimmer** (Constant Controls 2.34 cfs)  
 ↑ **3=Orifice/Grate** ( Controls 0.00 cfs)

**Secondary OutFlow** Max=0.00 cfs @ 5.00 hrs HW=450.00' (Free Discharge)  
 ↑ **4=Broad-Crested Rectangular Weir** ( Controls 0.00 cfs)

Pond 3P: P-P-SB-1

Hydrograph

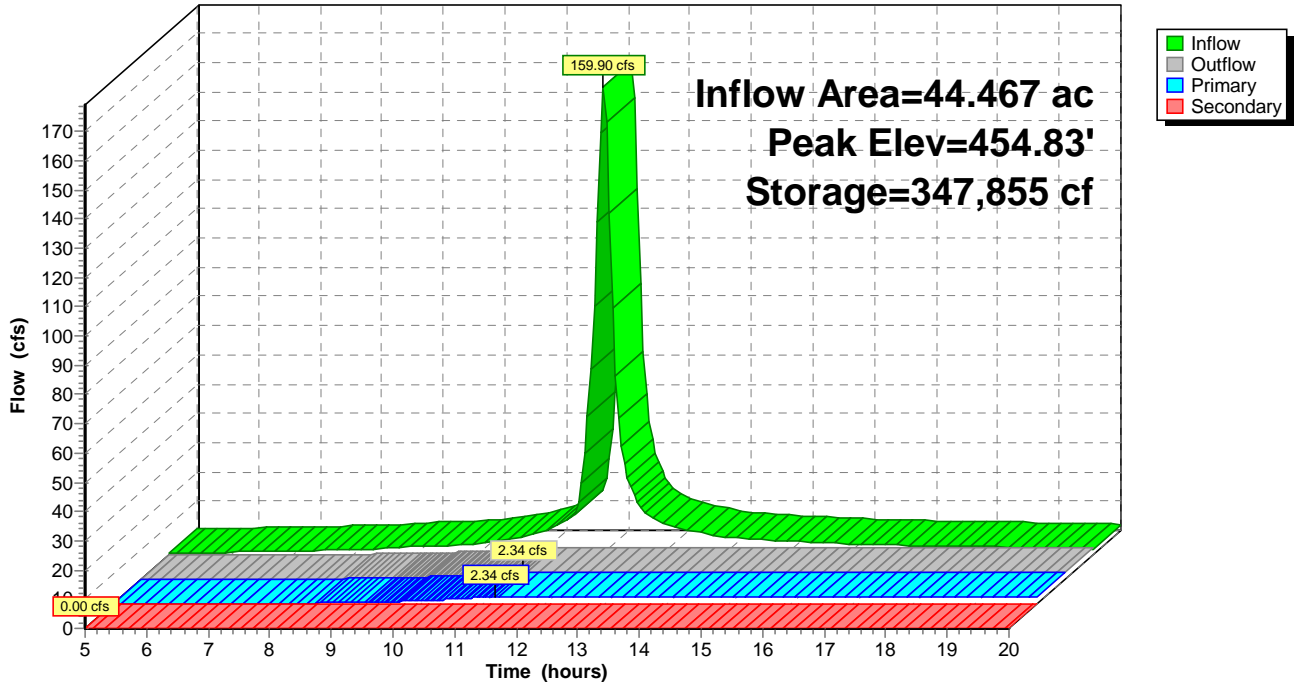



**210730C\_I77\_SEDIMENT\_BASINS**

Prepared by S&ME, Inc.

HydroCAD® 10.00-26 s/n 06707 © 2020 HydroCAD Software Solutions LLC

Type II 24-hr 2-yr Rainfall=3.54"

Printed 3/18/2021

Page 24

**Summary for Pond 4P: P-P-SB-2**

[82] Warning: Early inflow requires earlier time span

Inflow Area = 13.844 ac, 0.00% Impervious, Inflow Depth > 2.69" for 2-yr event  
 Inflow = 59.30 cfs @ 11.99 hrs, Volume= 3.108 af  
 Outflow = 0.89 cfs @ 10.75 hrs, Volume= 0.821 af, Atten= 98%, Lag= 0.0 min  
 Primary = 0.89 cfs @ 10.75 hrs, Volume= 0.821 af  
 Secondary = 0.00 cfs @ 5.00 hrs, Volume= 0.000 af

Routing by Stor-Ind method, Time Span= 5.00-20.00 hrs, dt= 0.05 hrs  
 Peak Elev= 485.21' @ 17.88 hrs Surf.Area= 28,872 sf Storage= 100,616 cf

Plug-Flow detention time= 238.5 min calculated for 0.818 af (26% of inflow)  
 Center-of-Mass det. time= 113.5 min ( 864.3 - 750.8 )

Volume	Invert	Avail.Storage	Storage Description
#1	481.00'	266,076 cf	<b>Custom Stage Data (Prismatic)</b> Listed below (Recalc)

Elevation (feet)	Surf.Area (sq-ft)	Inc.Store (cubic-feet)	Cum.Store (cubic-feet)
481.00	18,972	0	0
490.00	40,156	266,076	266,076

Device	Routing	Invert	Outlet Devices
#1	Device 2	481.00'	<b>0.894 cfs Constant Flow/Skimmer</b>
#2	Primary	481.00'	<b>24.0" Round Culvert</b> L= 100.0' CMP, square edge headwall, Ke= 0.500 Inlet / Outlet Invert= 481.00' / 480.00' S= 0.0100 '/' Cc= 0.900 n= 0.012 Concrete pipe, finished, Flow Area= 3.14 sf
#3	Device 2	487.40'	<b>36.0" x 36.0" Horiz. Orifice/Grate</b> C= 0.600 Limited to weir flow at low heads
#4	Secondary	488.40'	<b>20.0' long x 12.0' breadth Broad-Crested Rectangular Weir</b> Head (feet) 0.20 0.40 0.60 0.80 1.00 1.20 1.40 1.60 Coef. (English) 2.57 2.62 2.70 2.67 2.66 2.67 2.66 2.64

**Primary OutFlow** Max=0.89 cfs @ 10.75 hrs HW=481.45' (Free Discharge)  
 ↑ **2=Culvert** (Passes 0.89 cfs of 1.23 cfs potential flow)  
 ↑ **1=Constant Flow/Skimmer** (Constant Controls 0.89 cfs)  
 ↑ **3=Orifice/Grate** ( Controls 0.00 cfs)

**Secondary OutFlow** Max=0.00 cfs @ 5.00 hrs HW=481.00' (Free Discharge)  
 ↑ **4=Broad-Crested Rectangular Weir** ( Controls 0.00 cfs)

**210730C\_I77\_SEDIMENT\_BASINS**

Prepared by S&ME, Inc.

HydroCAD® 10.00-26 s/n 06707 © 2020 HydroCAD Software Solutions LLC

Type II 24-hr 2-yr Rainfall=3.54"

Printed 3/18/2021

Page 25

**Pond 4P: P-P-SB-2**

Hydrograph

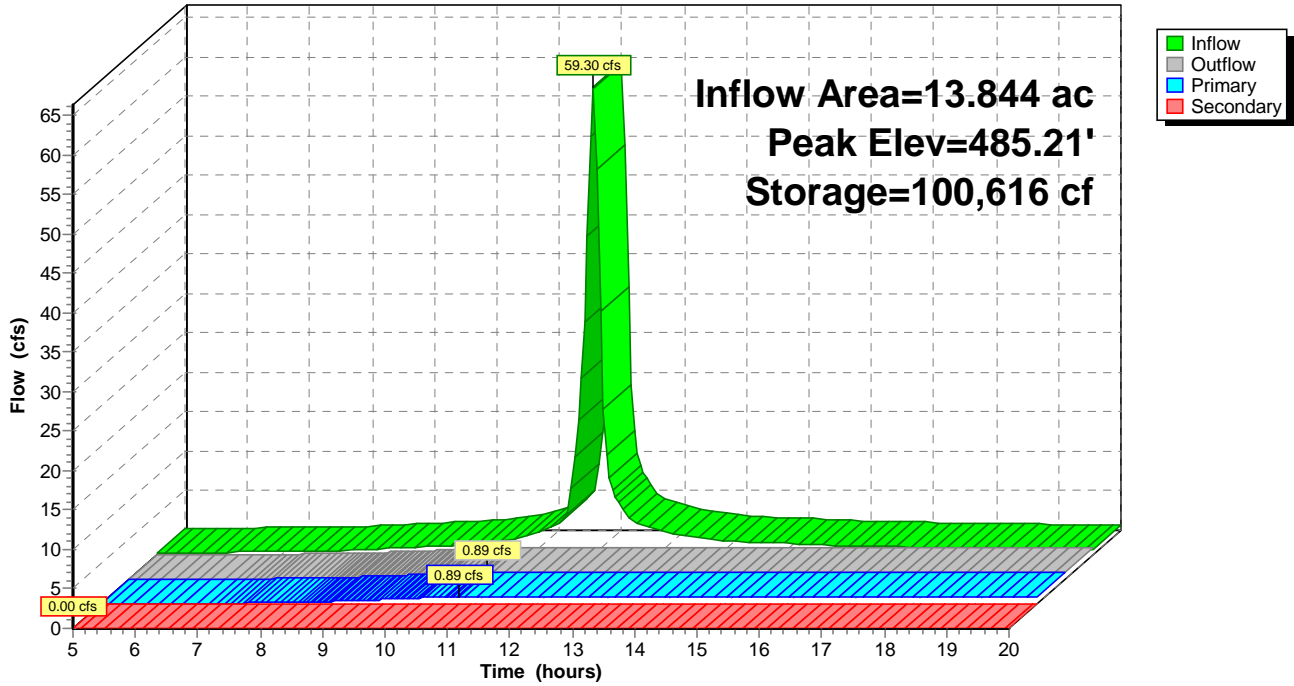

**210730C\_I77\_SEDIMENT\_BASINS**

Prepared by S&ME, Inc.

HydroCAD® 10.00-26 s/n 06707 © 2020 HydroCAD Software Solutions LLC

Type II 24-hr 2-yr Rainfall=3.54"

Printed 3/18/2021

Page 26

**Summary for Pond 5P: P-P-SB-3**

[82] Warning: Early inflow requires earlier time span

Inflow Area = 20.314 ac, 0.00% Impervious, Inflow Depth > 2.69" for 2-yr event  
 Inflow = 85.00 cfs @ 12.00 hrs, Volume= 4.560 af  
 Outflow = 1.17 cfs @ 10.60 hrs, Volume= 1.074 af, Atten= 99%, Lag= 0.0 min  
 Primary = 1.17 cfs @ 10.60 hrs, Volume= 1.074 af  
 Secondary = 0.00 cfs @ 5.00 hrs, Volume= 0.000 af

Routing by Stor-Ind method, Time Span= 5.00-20.00 hrs, dt= 0.05 hrs  
 Peak Elev= 494.84' @ 18.71 hrs Surf.Area= 37,975 sf Storage= 152,378 cf

Plug-Flow detention time= 248.5 min calculated for 1.073 af (24% of inflow)  
 Center-of-Mass det. time= 112.6 min ( 863.9 - 751.3 )

Volume	Invert	Avail.Storage	Storage Description
#1	490.00'	383,995 cf	<b>Custom Stage Data (Prismatic)</b> Listed below (Recalc)

Elevation (feet)	Surf.Area (sq-ft)	Inc.Store (cubic-feet)	Cum.Store (cubic-feet)
490.00	24,964	0	0
500.00	51,835	383,995	383,995

Device	Routing	Invert	Outlet Devices
#1	Device 2	490.00'	<b>1.168 cfs Constant Flow/Skimmer</b>
#2	Primary	490.00'	<b>24.0" Round Culvert</b> L= 100.0' CMP, square edge headwall, Ke= 0.500 Inlet / Outlet Invert= 490.00' / 489.00' S= 0.0100 '/' Cc= 0.900 n= 0.012 Concrete pipe, finished, Flow Area= 3.14 sf
#3	Device 2	497.30'	<b>36.0" x 36.0" Horiz. Orifice/Grate</b> C= 0.600 Limited to weir flow at low heads
#4	Secondary	498.30'	<b>20.0' long x 12.0' breadth Broad-Crested Rectangular Weir</b> Head (feet) 0.20 0.40 0.60 0.80 1.00 1.20 1.40 1.60 Coef. (English) 2.57 2.62 2.70 2.67 2.66 2.67 2.66 2.64

**Primary OutFlow** Max=1.17 cfs @ 10.60 hrs HW=490.50' (Free Discharge)  
 ↑ **2=Culvert** (Passes 1.17 cfs of 1.48 cfs potential flow)  
 ↑ **1=Constant Flow/Skimmer** (Constant Controls 1.17 cfs)  
 ↑ **3=Orifice/Grate** ( Controls 0.00 cfs)

**Secondary OutFlow** Max=0.00 cfs @ 5.00 hrs HW=490.00' (Free Discharge)  
 ↑ **4=Broad-Crested Rectangular Weir** ( Controls 0.00 cfs)

Pond 5P: P-P-SB-3

Hydrograph

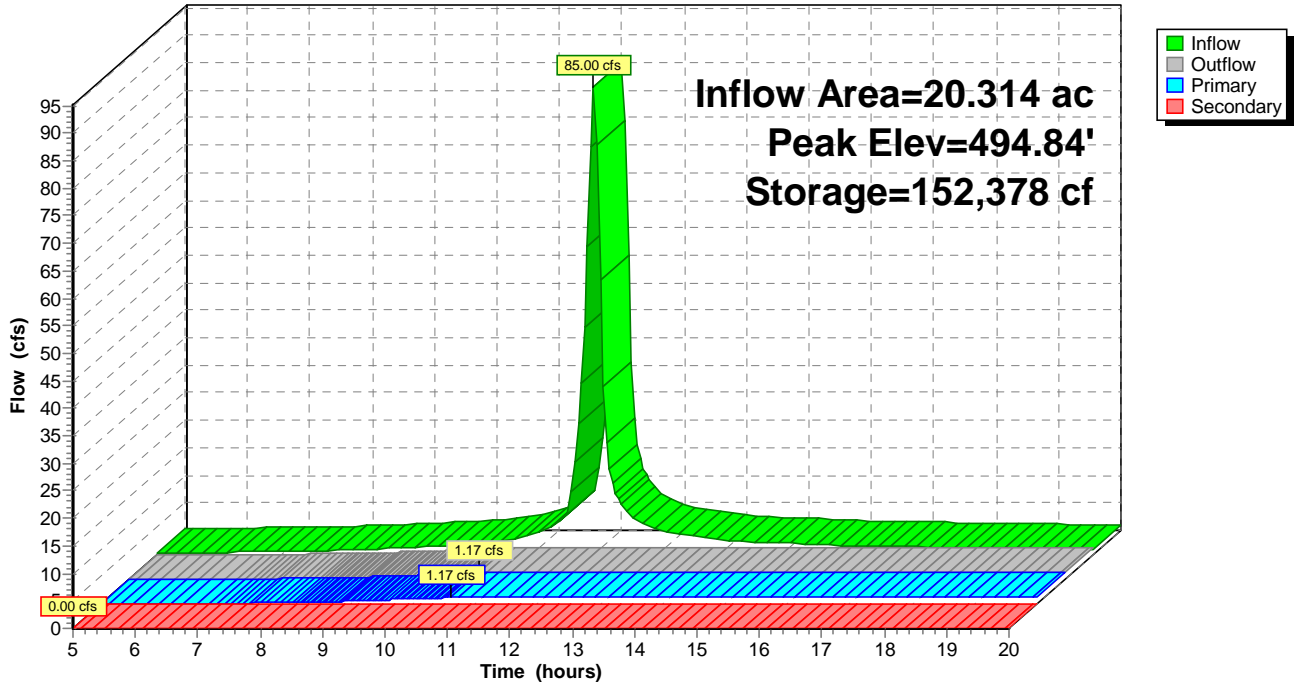

**210730C\_I77\_SEDIMENT\_BASINS**

Type II 24-hr 2-yr Rainfall=3.54"

Prepared by S&ME, Inc.

Printed 3/18/2021

HydroCAD® 10.00-26 s/n 06707 © 2020 HydroCAD Software Solutions LLC

Page 28

**Summary for Pond 6P: P-NE-SB-1**

[82] Warning: Early inflow requires earlier time span

Inflow Area = 20.801 ac, 0.00% Impervious, Inflow Depth > 2.69" for 2-yr event  
 Inflow = 84.97 cfs @ 12.01 hrs, Volume= 4.668 af  
 Outflow = 1.17 cfs @ 10.55 hrs, Volume= 1.081 af, Atten= 99%, Lag= 0.0 min  
 Primary = 1.17 cfs @ 10.55 hrs, Volume= 1.081 af  
 Secondary = 0.00 cfs @ 5.00 hrs, Volume= 0.000 af

Routing by Stor-Ind method, Time Span= 5.00-20.00 hrs, dt= 0.05 hrs  
 Peak Elev= 431.93' @ 18.88 hrs Surf.Area= 39,158 sf Storage= 156,699 cf

Plug-Flow detention time= 246.7 min calculated for 1.077 af (23% of inflow)  
 Center-of-Mass det. time= 110.0 min ( 861.9 - 751.9 )

Volume	Invert	Avail.Storage	Storage Description
#1	427.00'	393,720 cf	<b>Custom Stage Data (Prismatic)</b> Listed below (Recalc)

Elevation (feet)	Surf.Area (sq-ft)	Inc.Store (cubic-feet)	Cum.Store (cubic-feet)
427.00	24,435	0	0
437.00	54,309	393,720	393,720

Device	Routing	Invert	Outlet Devices
#1	Device 2	427.00'	<b>1.168 cfs Constant Flow/Skimmer</b>
#2	Primary	427.00'	<b>24.0" Round Culvert</b> L= 100.0' CMP, square edge headwall, Ke= 0.500 Inlet / Outlet Invert= 427.00' / 426.00' S= 0.0100 '/' Cc= 0.900 n= 0.012 Concrete pipe, finished, Flow Area= 3.14 sf
#3	Device 2	434.40'	<b>36.0" x 36.0" Horiz. Orifice/Grate</b> C= 0.600 Limited to weir flow at low heads
#4	Secondary	435.40'	<b>20.0' long x 12.0' breadth Broad-Crested Rectangular Weir</b> Head (feet) 0.20 0.40 0.60 0.80 1.00 1.20 1.40 1.60 Coef. (English) 2.57 2.62 2.70 2.67 2.66 2.67 2.66 2.64

**Primary OutFlow** Max=1.17 cfs @ 10.55 hrs HW=427.50' (Free Discharge)  
 ↑ **2=Culvert** (Passes 1.17 cfs of 1.49 cfs potential flow)  
 ↑ **1=Constant Flow/Skimmer** (Constant Controls 1.17 cfs)  
 ↑ **3=Orifice/Grate** ( Controls 0.00 cfs)

**Secondary OutFlow** Max=0.00 cfs @ 5.00 hrs HW=427.00' (Free Discharge)  
 ↑ **4=Broad-Crested Rectangular Weir** ( Controls 0.00 cfs)

Pond 6P: P-NE-SB-1

Hydrograph

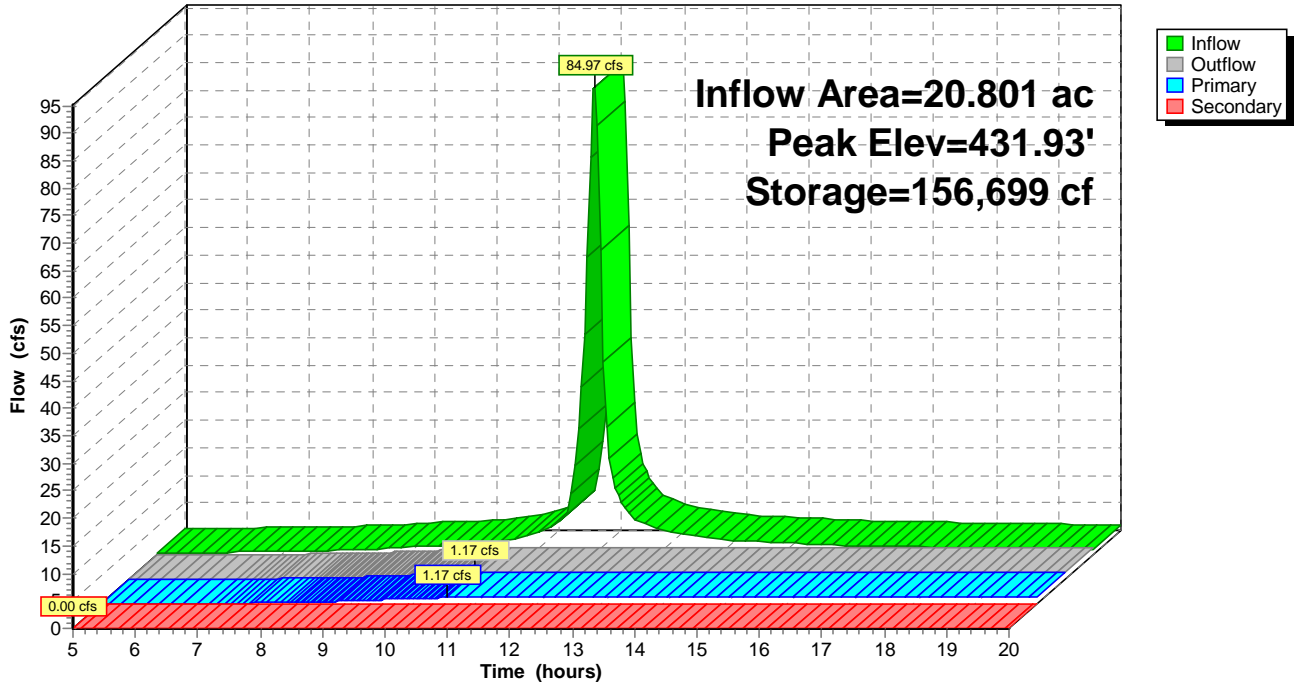

**210730C\_I77\_SEDIMENT\_BASINS**

Type II 24-hr 2-yr Rainfall=3.54"

Prepared by S&ME, Inc.

Printed 3/18/2021

HydroCAD® 10.00-26 s/n 06707 © 2020 HydroCAD Software Solutions LLC

Page 30

**Summary for Pond 7P: P-NE-SB-2**

[82] Warning: Early inflow requires earlier time span

Inflow Area = 7.668 ac, 0.00% Impervious, Inflow Depth > 2.70" for 2-yr event  
 Inflow = 34.49 cfs @ 11.97 hrs, Volume= 1.722 af  
 Outflow = 0.66 cfs @ 11.15 hrs, Volume= 0.587 af, Atten= 98%, Lag= 0.0 min  
 Primary = 0.66 cfs @ 11.15 hrs, Volume= 0.587 af  
 Secondary = 0.00 cfs @ 5.00 hrs, Volume= 0.000 af

Routing by Stor-Ind method, Time Span= 5.00-20.00 hrs, dt= 0.05 hrs  
 Peak Elev= 415.11' @ 15.84 hrs Surf.Area= 19,816 sf Storage= 51,963 cf

Plug-Flow detention time= 229.7 min calculated for 0.587 af (34% of inflow)  
 Center-of-Mass det. time= 123.6 min ( 872.8 - 749.2 )

Volume	Invert	Avail.Storage	Storage Description
#1	412.00'	172,776 cf	<b>Custom Stage Data (Prismatic)</b> Listed below (Recalc)

Elevation (feet)	Surf.Area (sq-ft)	Inc.Store (cubic-feet)	Cum.Store (cubic-feet)
412.00	13,554	0	0
420.00	29,640	172,776	172,776

Device	Routing	Invert	Outlet Devices
#1	Device 2	412.00'	<b>0.657 cfs Constant Flow/Skimmer</b>
#2	Primary	412.00'	<b>24.0" Round Culvert</b> L= 100.0' CMP, square edge headwall, Ke= 0.500 Inlet / Outlet Invert= 412.00' / 411.00' S= 0.0100 '/' Cc= 0.900 n= 0.012 Concrete pipe, finished, Flow Area= 3.14 sf
#3	Device 2	416.80'	<b>36.0" x 36.0" Horiz. Orifice/Grate</b> C= 0.600 Limited to weir flow at low heads
#4	Secondary	417.80'	<b>20.0' long x 12.0' breadth Broad-Crested Rectangular Weir</b> Head (feet) 0.20 0.40 0.60 0.80 1.00 1.20 1.40 1.60 Coef. (English) 2.57 2.62 2.70 2.67 2.66 2.67 2.66 2.64

**Primary OutFlow** Max=0.66 cfs @ 11.15 hrs HW=412.41' (Free Discharge)  
 ↑ **2=Culvert** (Passes 0.66 cfs of 1.01 cfs potential flow)  
 ↑ **1=Constant Flow/Skimmer** (Constant Controls 0.66 cfs)  
 ↑ **3=Orifice/Grate** ( Controls 0.00 cfs)

**Secondary OutFlow** Max=0.00 cfs @ 5.00 hrs HW=412.00' (Free Discharge)  
 ↑ **4=Broad-Crested Rectangular Weir** ( Controls 0.00 cfs)

Pond 7P: P-NE-SB-2

Hydrograph

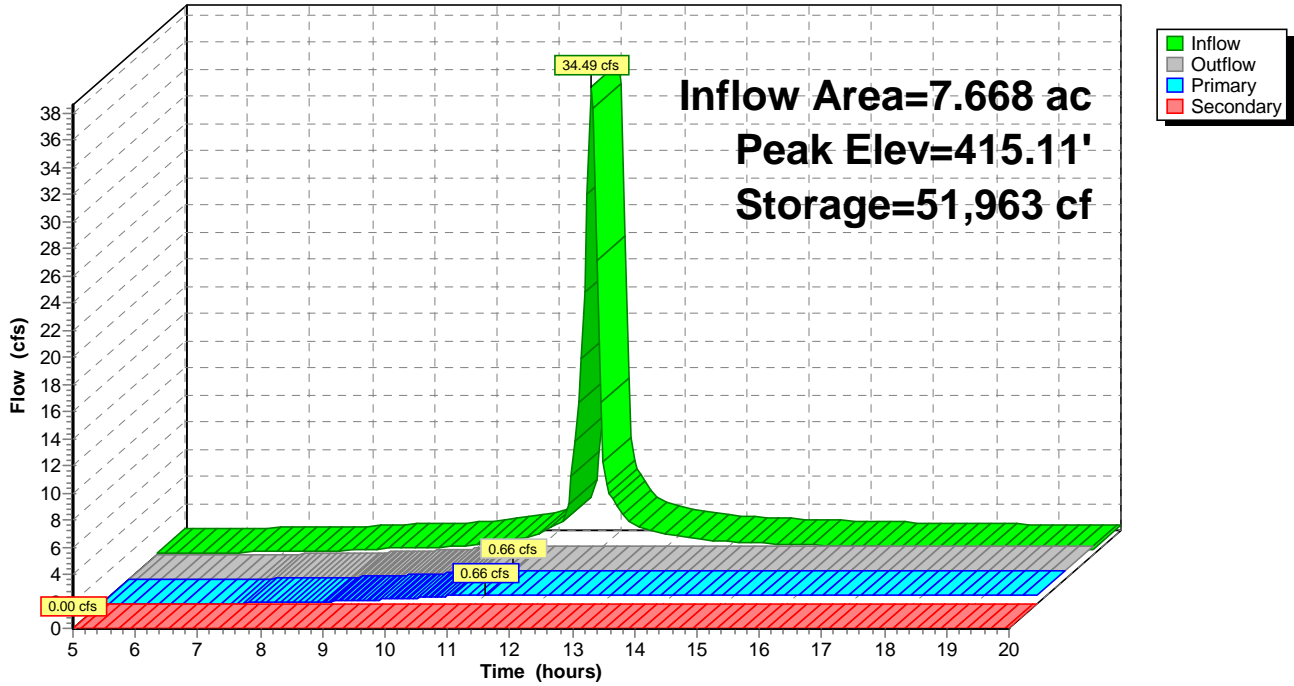



**210730C\_I77\_SEDIMENT\_BASINS**

Type II 24-hr 2-yr Rainfall=3.54"

Prepared by S&ME, Inc.

Printed 3/18/2021

HydroCAD® 10.00-26 s/n 06707 © 2020 HydroCAD Software Solutions LLC

Page 32

**Summary for Pond 8P: P-NE-SB-3**

[82] Warning: Early inflow requires earlier time span

Inflow Area = 10.129 ac, 0.00% Impervious, Inflow Depth > 2.69" for 2-yr event  
 Inflow = 45.15 cfs @ 11.98 hrs, Volume= 2.274 af  
 Outflow = 0.66 cfs @ 10.40 hrs, Volume= 0.615 af, Atten= 99%, Lag= 0.0 min  
 Primary = 0.66 cfs @ 10.40 hrs, Volume= 0.615 af  
 Secondary = 0.00 cfs @ 5.00 hrs, Volume= 0.000 af

Routing by Stor-Ind method, Time Span= 5.00-20.00 hrs, dt= 0.05 hrs  
 Peak Elev= 415.98' @ 17.82 hrs Surf.Area= 22,709 sf Storage= 73,062 cf

Plug-Flow detention time= 231.2 min calculated for 0.612 af (27% of inflow)  
 Center-of-Mass det. time= 108.2 min ( 857.9 - 749.7 )

Volume	Invert	Avail.Storage	Storage Description
#1	412.00'	214,574 cf	<b>Custom Stage Data (Prismatic)</b> Listed below (Recalc)

Elevation (feet)	Surf.Area (sq-ft)	Inc.Store (cubic-feet)	Cum.Store (cubic-feet)
412.00	13,973	0	0
421.00	33,710	214,574	214,574

Device	Routing	Invert	Outlet Devices
#1	Device 2	412.00'	<b>0.657 cfs Constant Flow/Skimmer</b>
#2	Primary	412.00'	<b>24.0" Round Culvert</b> L= 100.0' CMP, square edge headwall, Ke= 0.500 Inlet / Outlet Invert= 412.00' / 411.00' S= 0.0100 '/' Cc= 0.900 n= 0.012 Concrete pipe, finished, Flow Area= 3.14 sf
#3	Device 2	418.00'	<b>36.0" x 36.0" Horiz. Orifice/Grate</b> C= 0.600 Limited to weir flow at low heads
#4	Secondary	419.00'	<b>20.0' long x 12.0' breadth Broad-Crested Rectangular Weir</b> Head (feet) 0.20 0.40 0.60 0.80 1.00 1.20 1.40 1.60 Coef. (English) 2.57 2.62 2.70 2.67 2.66 2.67 2.66 2.64

**Primary OutFlow** Max=0.66 cfs @ 10.40 hrs HW=412.36' (Free Discharge)  
 ↑ **2=Culvert** (Passes 0.66 cfs of 0.79 cfs potential flow)  
 ↑ **1=Constant Flow/Skimmer** (Constant Controls 0.66 cfs)  
 ↑ **3=Orifice/Grate** ( Controls 0.00 cfs)

**Secondary OutFlow** Max=0.00 cfs @ 5.00 hrs HW=412.00' (Free Discharge)  
 ↑ **4=Broad-Crested Rectangular Weir** ( Controls 0.00 cfs)

Pond 8P: P-NE-SB-3

Hydrograph

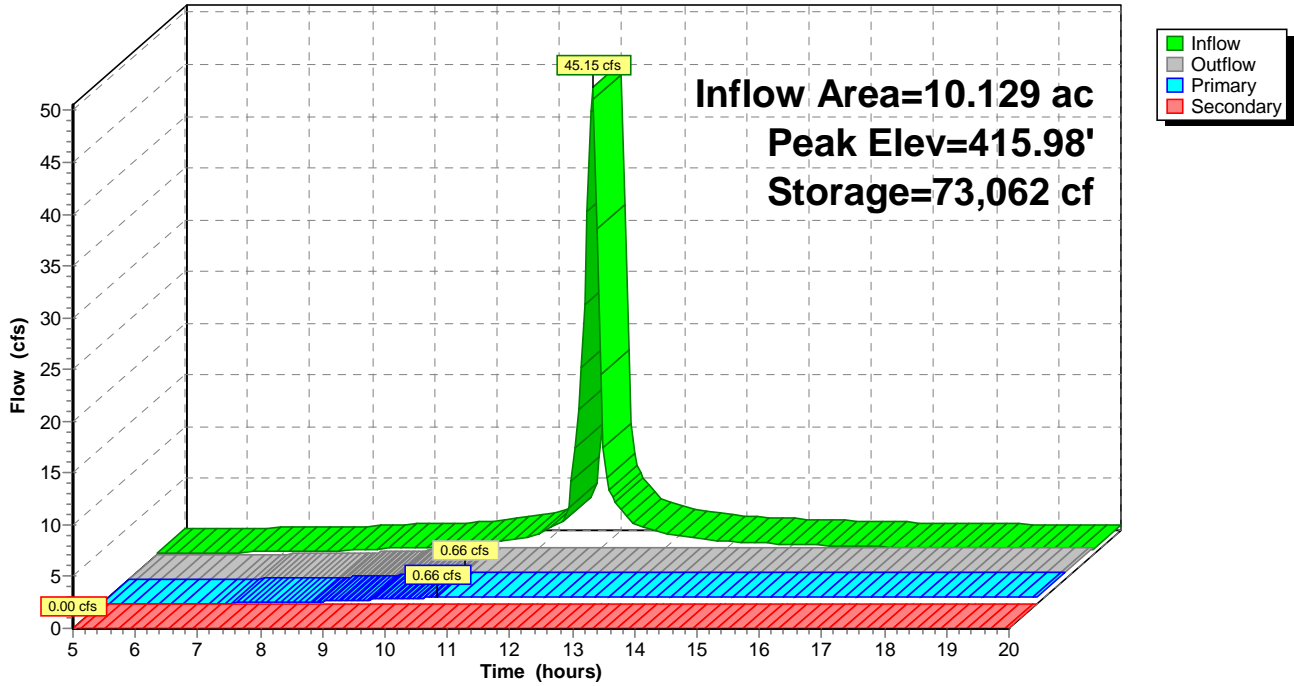

**210730C\_I77\_SEDIMENT\_BASINS**

Type II 24-hr 2-yr Rainfall=3.54"

Prepared by S&ME, Inc.

Printed 3/18/2021

HydroCAD® 10.00-26 s/n 06707 © 2020 HydroCAD Software Solutions LLC

Page 34

**Summary for Pond 9P: P-NE-SB-4**

[82] Warning: Early inflow requires earlier time span

Inflow Area = 15.592 ac, 0.00% Impervious, Inflow Depth > 2.69" for 2-yr event  
 Inflow = 66.78 cfs @ 11.99 hrs, Volume= 3.500 af  
 Outflow = 1.17 cfs @ 11.10 hrs, Volume= 1.008 af, Atten= 98%, Lag= 0.0 min  
 Primary = 1.17 cfs @ 11.10 hrs, Volume= 1.008 af  
 Secondary = 0.00 cfs @ 5.00 hrs, Volume= 0.000 af

Routing by Stor-Ind method, Time Span= 5.00-20.00 hrs, dt= 0.05 hrs  
 Peak Elev= 482.49' @ 16.67 hrs Surf.Area= 36,360 sf Storage= 111,255 cf

Plug-Flow detention time= 251.0 min calculated for 1.005 af (29% of inflow)  
 Center-of-Mass det. time= 133.1 min ( 883.9 - 750.8 )

Volume	Invert	Avail.Storage	Storage Description
#1	479.00'	301,356 cf	<b>Custom Stage Data (Prismatic)</b> Listed below (Recalc)

Elevation (feet)	Surf.Area (sq-ft)	Inc.Store (cubic-feet)	Cum.Store (cubic-feet)
479.00	27,386	0	0
487.00	47,953	301,356	301,356

Device	Routing	Invert	Outlet Devices
#1	Device 2	479.00'	<b>1.168 cfs Constant Flow/Skimmer</b>
#2	Primary	479.00'	<b>24.0" Round Culvert</b> L= 100.0' CMP, square edge headwall, Ke= 0.500 Inlet / Outlet Invert= 479.00' / 478.00' S= 0.0100 '/' Cc= 0.900 n= 0.012 Concrete pipe, finished, Flow Area= 3.14 sf
#3	Device 2	484.50'	<b>36.0" x 36.0" Horiz. Orifice/Grate</b> C= 0.600 Limited to weir flow at low heads
#4	Secondary	485.50'	<b>20.0' long x 12.0' breadth Broad-Crested Rectangular Weir</b> Head (feet) 0.20 0.40 0.60 0.80 1.00 1.20 1.40 1.60 Coef. (English) 2.57 2.62 2.70 2.67 2.66 2.67 2.66 2.64

**Primary OutFlow** Max=1.17 cfs @ 11.10 hrs HW=479.49' (Free Discharge)  
 ↑ **2=Culvert** (Passes 1.17 cfs of 1.40 cfs potential flow)  
 ↑ **1=Constant Flow/Skimmer** (Constant Controls 1.17 cfs)  
 ↑ **3=Orifice/Grate** ( Controls 0.00 cfs)

**Secondary OutFlow** Max=0.00 cfs @ 5.00 hrs HW=479.00' (Free Discharge)  
 ↑ **4=Broad-Crested Rectangular Weir** ( Controls 0.00 cfs)

Pond 9P: P-NE-SB-4

Hydrograph

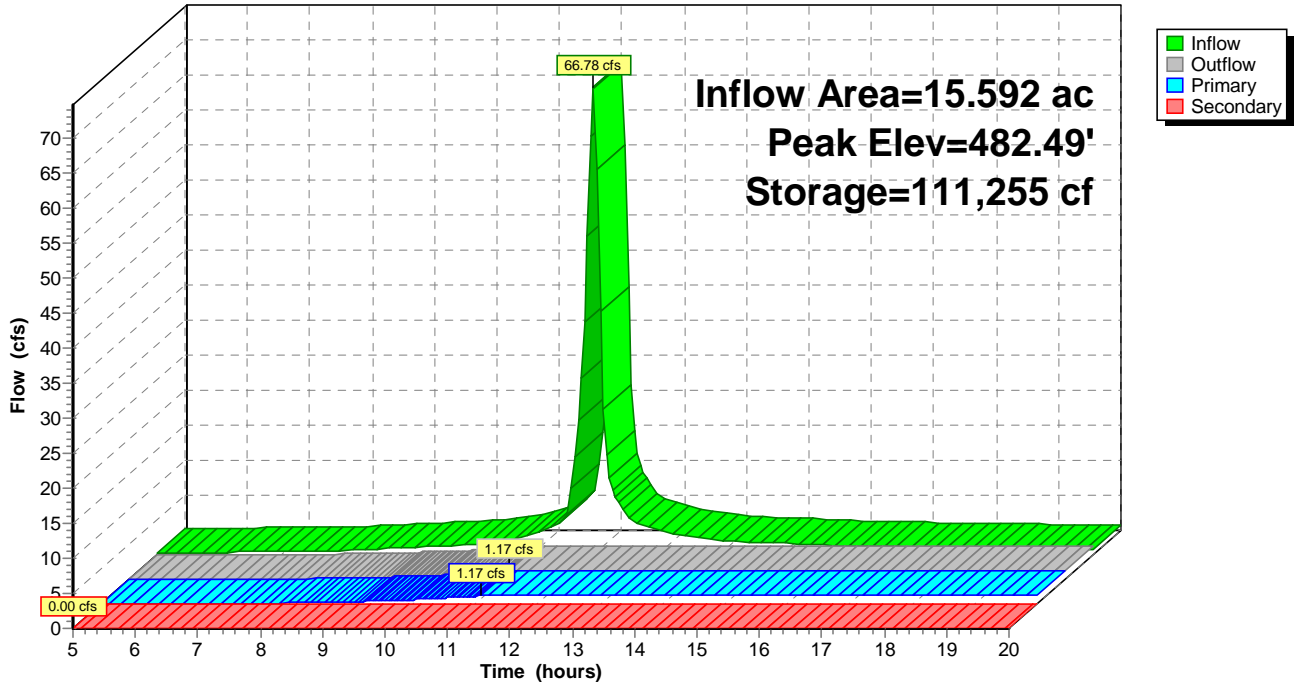

**210730C\_I77\_SEDIMENT\_BASINS**

Type II 24-hr 10-yr Rainfall=5.14"

Prepared by S&amp;ME, Inc.

Printed 3/18/2021

HydroCAD® 10.00-26 s/n 06707 © 2020 HydroCAD Software Solutions LLC

Page 36

Time span=5.00-20.00 hrs, dt=0.05 hrs, 301 points  
 Runoff by SCS TR-20 method, UH=SCS, Weighted-CN  
 Reach routing by Stor-Ind+Trans method - Pond routing by Stor-Ind method

<b>Subcatchment NE1: NE-SB-1</b>	Runoff Area=906,076 sf 0.00% Impervious Runoff Depth>4.15" Flow Length=990' Tc=9.9 min CN=94 Runoff=127.97 cfs 7.200 af
<b>Subcatchment NE2: NE-SB-2</b>	Runoff Area=334,011 sf 0.00% Impervious Runoff Depth>4.16" Flow Length=640' Tc=6.4 min CN=94 Runoff=51.88 cfs 2.655 af
<b>Subcatchment NE3: NE-SB-3</b>	Runoff Area=441,198 sf 0.00% Impervious Runoff Depth>4.16" Flow Length=840' Tc=7.1 min CN=94 Runoff=67.89 cfs 3.507 af
<b>Subcatchment NE4: NE-SB-4</b>	Runoff Area=679,173 sf 0.00% Impervious Runoff Depth>4.15" Flow Length=1,778' Tc=8.5 min CN=94 Runoff=100.49 cfs 5.398 af
<b>Subcatchment P1: P-SB-1</b>	Runoff Area=1,936,988 sf 0.00% Impervious Runoff Depth>4.15" Flow Length=1,935' Tc=14.1 min CN=94 Runoff=241.19 cfs 15.383 af
<b>Subcatchment P2: P-SB-2</b>	Runoff Area=603,049 sf 0.00% Impervious Runoff Depth>4.15" Flow Length=1,182' Tc=8.5 min CN=94 Runoff=89.23 cfs 4.793 af
<b>Subcatchment P3: P-SB-3</b>	Runoff Area=884,859 sf 0.00% Impervious Runoff Depth>4.15" Flow Length=1,112' Tc=9.2 min CN=94 Runoff=127.96 cfs 7.032 af
<b>Subcatchment PT1: PT-SB-1</b>	Runoff Area=1,012,355 sf 0.00% Impervious Runoff Depth>4.15" Flow Length=1,104' Tc=11.5 min CN=94 Runoff=135.91 cfs 8.043 af
<b>Subcatchment W1: W-SB-1</b>	Runoff Area=599,872 sf 0.00% Impervious Runoff Depth>4.15" Flow Length=1,193' Tc=7.9 min CN=94 Runoff=90.38 cfs 4.768 af
<b>Pond 1P: P-PT-SB-1</b>	Peak Elev=562.68' Storage=300,166 cf Inflow=135.91 cfs 8.043 af Primary=1.17 cfs 1.151 af Secondary=0.00 cfs 0.000 af Outflow=1.17 cfs 1.151 af
<b>Pond 2P: P-W-SB-1</b>	Peak Elev=505.39' Storage=168,705 cf Inflow=90.38 cfs 4.768 af Primary=0.89 cfs 0.895 af Secondary=0.00 cfs 0.000 af Outflow=0.89 cfs 0.895 af
<b>Pond 3P: P-P-SB-1</b>	Peak Elev=457.36' Storage=571,220 cf Inflow=241.19 cfs 15.383 af Primary=2.34 cfs 2.268 af Secondary=0.00 cfs 0.000 af Outflow=2.34 cfs 2.268 af
<b>Pond 4P: P-P-SB-2</b>	Peak Elev=487.37' Storage=168,475 cf Inflow=89.23 cfs 4.793 af Primary=0.89 cfs 0.925 af Secondary=0.00 cfs 0.000 af Outflow=0.89 cfs 0.925 af
<b>Pond 5P: P-P-SB-3</b>	Peak Elev=497.29' Storage=253,602 cf Inflow=127.96 cfs 7.032 af Primary=1.17 cfs 1.210 af Secondary=0.00 cfs 0.000 af Outflow=1.17 cfs 1.210 af
<b>Pond 6P: P-NE-SB-1</b>	Peak Elev=434.36' Storage=260,626 cf Inflow=127.97 cfs 7.200 af Primary=1.17 cfs 1.216 af Secondary=0.00 cfs 0.000 af Outflow=1.17 cfs 1.216 af
<b>Pond 7P: P-NE-SB-2</b>	Peak Elev=416.75' Storage=87,108 cf Inflow=51.88 cfs 2.655 af Primary=0.66 cfs 0.664 af Secondary=0.00 cfs 0.000 af Outflow=0.66 cfs 0.664 af

**210730C\_I77\_SEDIMENT\_BASINS**

Type II 24-hr 10-yr Rainfall=5.14"

Prepared by S&ME, Inc.

Printed 3/18/2021

HydroCAD® 10.00-26 s/n 06707 © 2020 HydroCAD Software Solutions LLC

Page 37

**Pond 8P: P-NE-SB-3**

Peak Elev=417.98' Storage=122,681 cf Inflow=67.89 cfs 3.507 af  
Primary=0.66 cfs 0.691 af Secondary=0.00 cfs 0.000 af Outflow=0.66 cfs 0.691 af

**Pond 9P: P-NE-SB-4**

Peak Elev=484.40' Storage=185,391 cf Inflow=100.49 cfs 5.398 af  
Primary=1.17 cfs 1.145 af Secondary=0.00 cfs 0.000 af Outflow=1.17 cfs 1.145 af

**Total Runoff Area = 169.825 ac Runoff Volume = 58.781 af Average Runoff Depth = 4.15"**  
**100.00% Pervious = 169.825 ac 0.00% Impervious = 0.000 ac**

**210730C\_I77\_SEDIMENT\_BASINS**

Prepared by S&ME, Inc.

HydroCAD® 10.00-26 s/n 06707 © 2020 HydroCAD Software Solutions LLC

Type II 24-hr 10-yr Rainfall=5.14"

Printed 3/18/2021

Page 38

**Summary for Subcatchment NE1: NE-SB-1**

Runoff = 127.97 cfs @ 12.01 hrs, Volume= 7.200 af, Depth> 4.15"

Runoff by SCS TR-20 method, UH=SCS, Weighted-CN, Time Span= 5.00-20.00 hrs, dt= 0.05 hrs  
 Type II 24-hr 10-yr Rainfall=5.14"

Area (sf)	CN	Description
906,076	94	Newly graded area, HSG D
906,076		100.00% Pervious Area

Tc (min)	Length (feet)	Slope (ft/ft)	Velocity (ft/sec)	Capacity (cfs)	Description
6.7	300	0.0464	0.75		<b>Sheet Flow,</b> Fallow n= 0.050 P2= 3.54"
3.2	690	0.1262	3.55		<b>Shallow Concentrated Flow,</b> Nearly Bare & Untilled Kv= 10.0 fps
9.9	990	Total			

**Subcatchment NE1: NE-SB-1**

Hydrograph

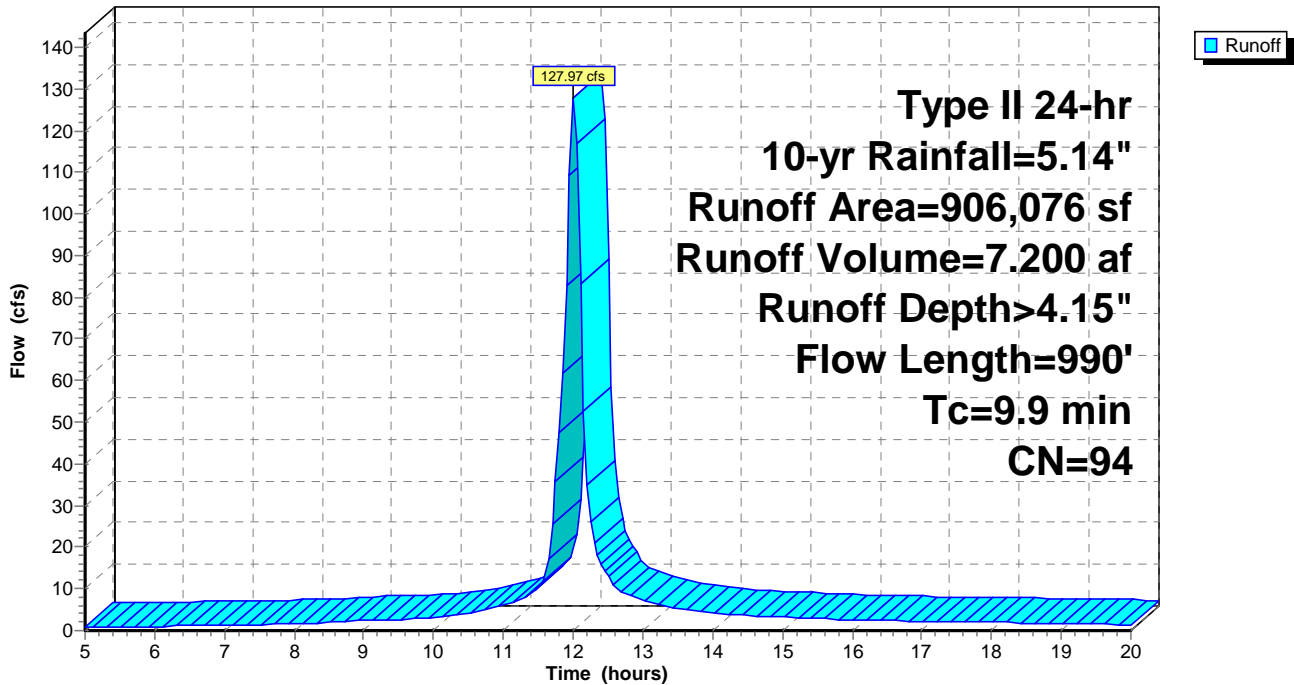

**210730C\_I77\_SEDIMENT\_BASINS**

Prepared by S&ME, Inc.

HydroCAD® 10.00-26 s/n 06707 © 2020 HydroCAD Software Solutions LLC

Type II 24-hr 10-yr Rainfall=5.14"

Printed 3/18/2021

Page 39

**Summary for Subcatchment NE2: NE-SB-2**

No Channel Flow

Runoff = 51.88 cfs @ 11.97 hrs, Volume= 2.655 af, Depth> 4.16"

Runoff by SCS TR-20 method, UH=SCS, Weighted-CN, Time Span= 5.00-20.00 hrs, dt= 0.05 hrs  
Type II 24-hr 10-yr Rainfall=5.14"

Area (sf)	CN	Description
334,011	94	Newly graded area, HSG D
334,011		100.00% Pervious Area

Tc (min)	Length (feet)	Slope (ft/ft)	Velocity (ft/sec)	Capacity (cfs)	Description
5.3	300	0.0812	0.94		<b>Sheet Flow,</b> Fallow n= 0.050 P2= 3.54"
1.1	340	0.2754	5.25		<b>Shallow Concentrated Flow,</b> Nearly Bare & Untilled Kv= 10.0 fps
6.4	640	Total			

**Subcatchment NE2: NE-SB-2**

Hydrograph

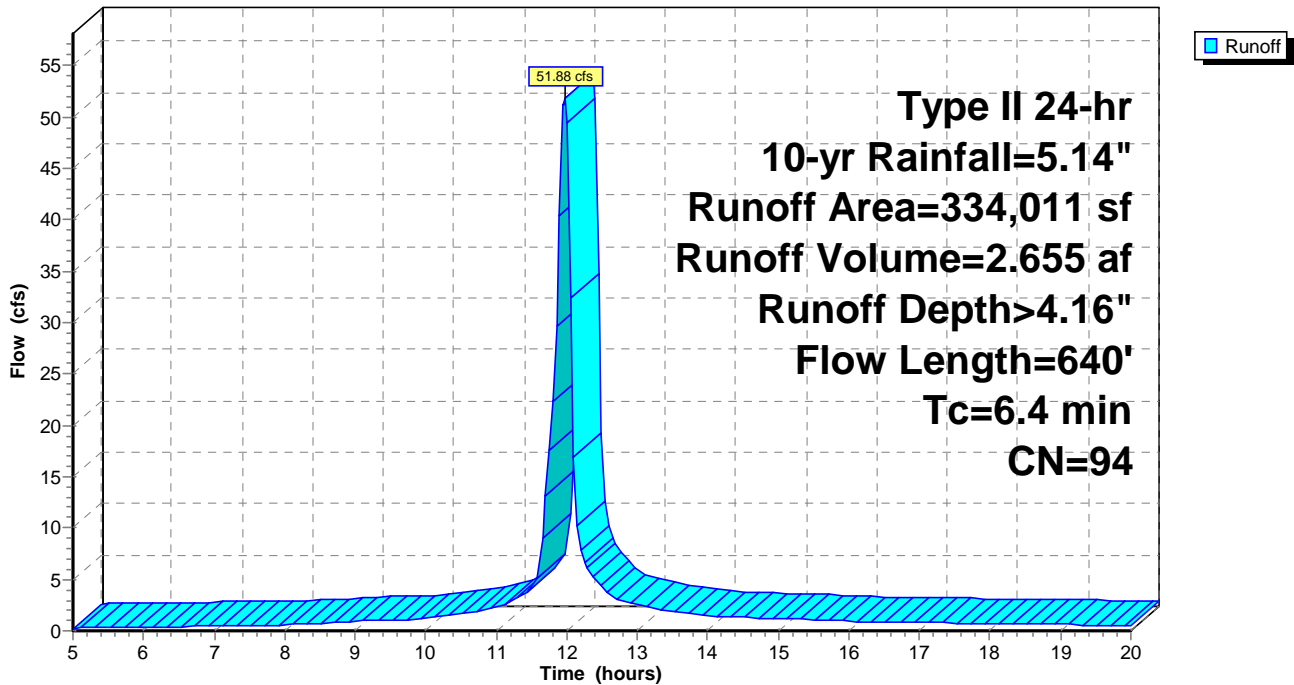



**210730C\_I77\_SEDIMENT\_BASINS**

Prepared by S&ME, Inc.

HydroCAD® 10.00-26 s/n 06707 © 2020 HydroCAD Software Solutions LLC

Type II 24-hr 10-yr Rainfall=5.14"

Printed 3/18/2021

Page 40

**Summary for Subcatchment NE3: NE-SB-3**

No Channel Flow

Runoff = 67.89 cfs @ 11.98 hrs, Volume= 3.507 af, Depth> 4.16"

Runoff by SCS TR-20 method, UH=SCS, Weighted-CN, Time Span= 5.00-20.00 hrs, dt= 0.05 hrs  
Type II 24-hr 10-yr Rainfall=5.14"

Area (sf)	CN	Description
441,198	94	Newly graded area, HSG D
441,198		100.00% Pervious Area

Tc (min)	Length (feet)	Slope (ft/ft)	Velocity (ft/sec)	Capacity (cfs)	Description
4.8	300	0.1075	1.05		<b>Sheet Flow,</b> Fallow n= 0.050 P2= 3.54"
2.3	540	0.1570	3.96		<b>Shallow Concentrated Flow,</b> Nearly Bare & Untilled Kv= 10.0 fps
7.1	840	Total			

**Subcatchment NE3: NE-SB-3**

Hydrograph

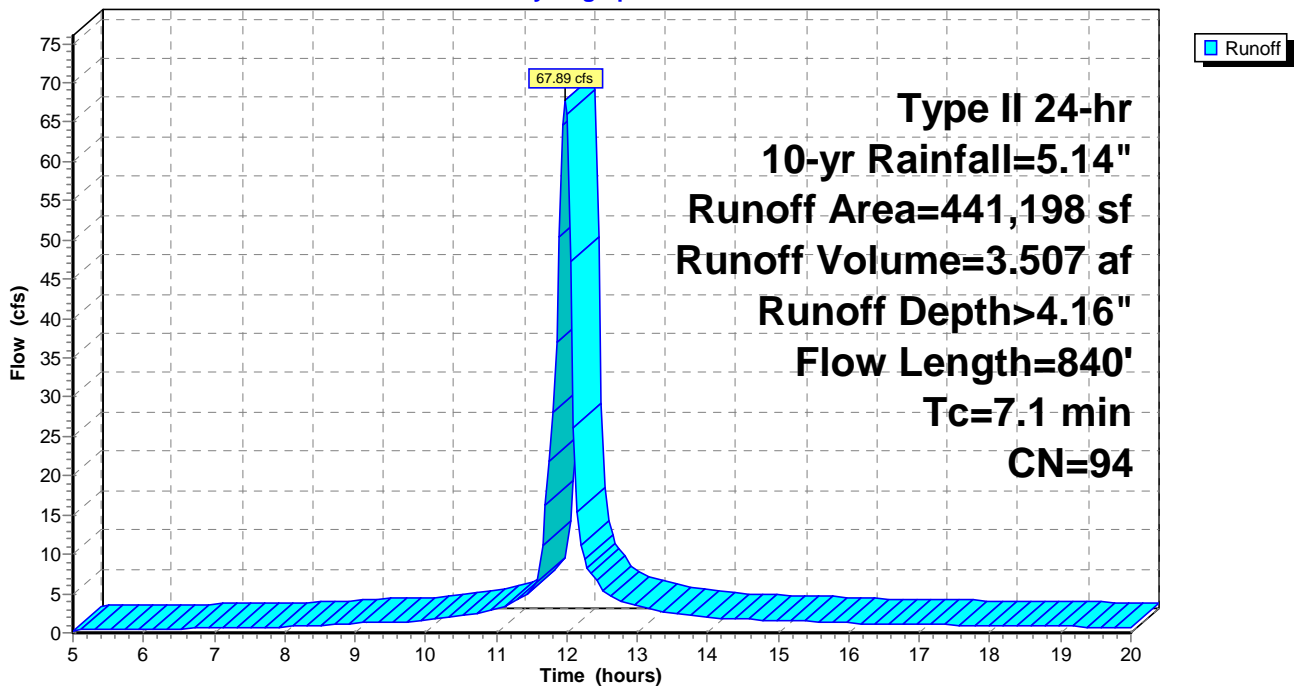

**210730C\_I77\_SEDIMENT\_BASINS**

Prepared by S&ME, Inc.

HydroCAD® 10.00-26 s/n 06707 © 2020 HydroCAD Software Solutions LLC

Type II 24-hr 10-yr Rainfall=5.14"

Printed 3/18/2021

Page 41

**Summary for Subcatchment NE4: NE-SB-4**

No Channel Flow

Runoff = 100.49 cfs @ 11.99 hrs, Volume= 5.398 af, Depth> 4.15"

Runoff by SCS TR-20 method, UH=SCS, Weighted-CN, Time Span= 5.00-20.00 hrs, dt= 0.05 hrs  
Type II 24-hr 10-yr Rainfall=5.14"

Area (sf)	CN	Description
679,173	94	Newly graded area, HSG D
679,173		100.00% Pervious Area

Tc (min)	Length (feet)	Slope (ft/ft)	Velocity (ft/sec)	Capacity (cfs)	Description
5.6	300	0.0719	0.90		<b>Sheet Flow,</b> Fallow n= 0.050 P2= 3.54"
1.8	290	0.0706	2.66		<b>Shallow Concentrated Flow,</b> Nearly Bare & Untilled Kv= 10.0 fps
1.1	1,188	0.0328	17.76	621.77	<b>Channel Flow,</b> Area= 35.0 sf Perim= 20.0' r= 1.75' n= 0.022 Earth, clean & straight
8.5	1,778	Total			

**Subcatchment NE4: NE-SB-4**

Hydrograph

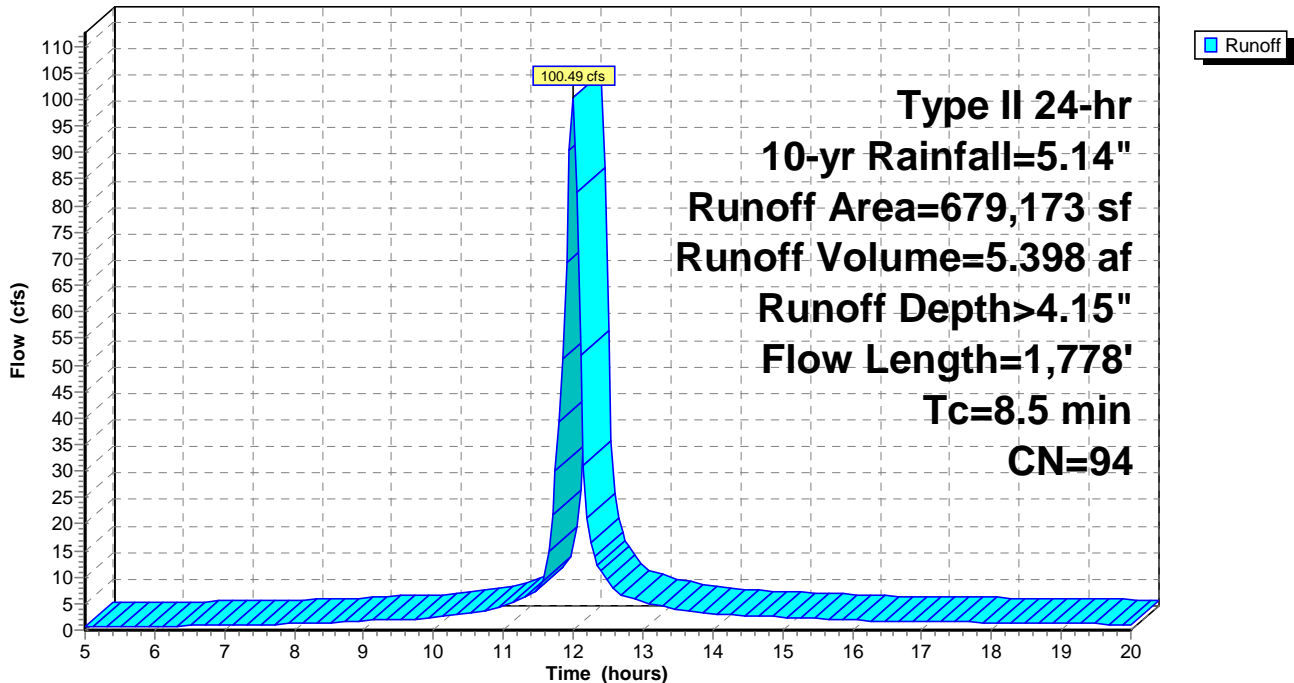

**210730C\_I77\_SEDIMENT\_BASINS**

Prepared by S&ME, Inc.

HydroCAD® 10.00-26 s/n 06707 © 2020 HydroCAD Software Solutions LLC

Type II 24-hr 10-yr Rainfall=5.14"

Printed 3/18/2021

Page 42

**Summary for Subcatchment P1: P-SB-1**

No Channel Flow

Runoff = 241.19 cfs @ 12.05 hrs, Volume= 15.383 af, Depth> 4.15"

Runoff by SCS TR-20 method, UH=SCS, Weighted-CN, Time Span= 5.00-20.00 hrs, dt= 0.05 hrs  
Type II 24-hr 10-yr Rainfall=5.14"

Area (sf)	CN	Description
1,936,988	94	Newly graded area, HSG D
1,936,988		100.00% Pervious Area

Tc (min)	Length (feet)	Slope (ft/ft)	Velocity (ft/sec)	Capacity (cfs)	Description
5.3	300	0.0838	0.95		<b>Sheet Flow,</b> Fallow n= 0.050 P2= 3.54"
7.9	1,294	0.0737	2.71		<b>Shallow Concentrated Flow,</b> Nearly Bare & Untilled Kv= 10.0 fps
0.9	341	0.0045	6.58	230.30	<b>Channel Flow,</b> Area= 35.0 sf Perim= 20.0' r= 1.75' n= 0.022 Earth, clean & straight
14.1	1,935	Total			

**Subcatchment P1: P-SB-1**

Hydrograph

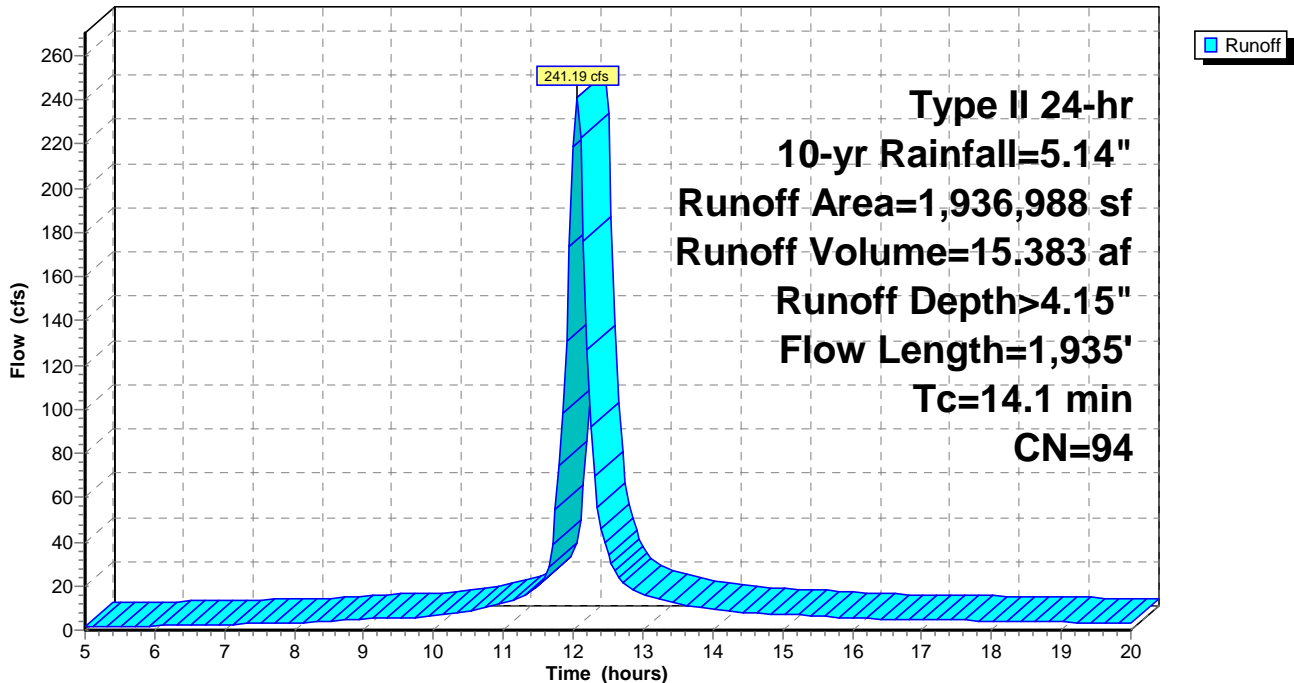

**210730C\_I77\_SEDIMENT\_BASINS**

Prepared by S&ME, Inc.

HydroCAD® 10.00-26 s/n 06707 © 2020 HydroCAD Software Solutions LLC

Type II 24-hr 10-yr Rainfall=5.14"

Printed 3/18/2021

Page 43

**Summary for Subcatchment P2: P-SB-2**

No Channel Flow

Runoff = 89.23 cfs @ 11.99 hrs, Volume= 4.793 af, Depth> 4.15"

Runoff by SCS TR-20 method, UH=SCS, Weighted-CN, Time Span= 5.00-20.00 hrs, dt= 0.05 hrs  
Type II 24-hr 10-yr Rainfall=5.14"

Area (sf)	CN	Description
603,049	94	Newly graded area, HSG D
603,049		100.00% Pervious Area

Tc (min)	Length (feet)	Slope (ft/ft)	Velocity (ft/sec)	Capacity (cfs)	Description
5.2	300	0.0842	0.95		<b>Sheet Flow,</b> Fallow n= 0.050 P2= 3.54"
3.0	582	0.1023	3.20		<b>Shallow Concentrated Flow,</b> Nearly Bare & Untilled Kv= 10.0 fps
0.3	300	0.0240	15.20	531.86	<b>Channel Flow,</b> Area= 35.0 sf Perim= 20.0' r= 1.75' n= 0.022 Earth, clean & straight

8.5 1,182 Total

**Subcatchment P2: P-SB-2**

Hydrograph

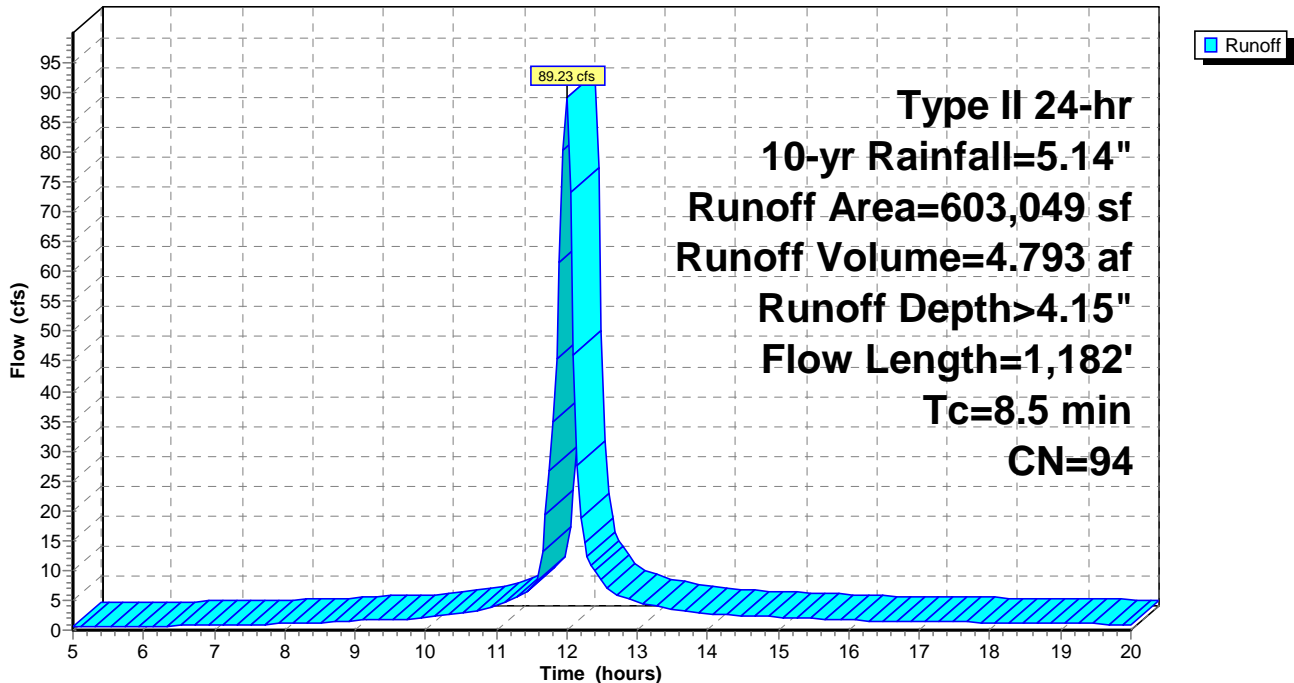

**210730C\_I77\_SEDIMENT\_BASINS**

Prepared by S&ME, Inc.

HydroCAD® 10.00-26 s/n 06707 © 2020 HydroCAD Software Solutions LLC

Type II 24-hr 10-yr Rainfall=5.14"

Printed 3/18/2021

Page 44

**Summary for Subcatchment P3: P-SB-3**

Runoff = 127.96 cfs @ 12.00 hrs, Volume= 7.032 af, Depth> 4.15"

Runoff by SCS TR-20 method, UH=SCS, Weighted-CN, Time Span= 5.00-20.00 hrs, dt= 0.05 hrs  
Type II 24-hr 10-yr Rainfall=5.14"

Area (sf)	CN	Description
884,859	94	Newly graded area, HSG D
884,859		100.00% Pervious Area

Tc (min)	Length (feet)	Slope (ft/ft)	Velocity (ft/sec)	Capacity (cfs)	Description
4.7	300	0.1095	1.06		<b>Sheet Flow,</b> Fallow n= 0.050 P2= 3.54"
4.3	699	0.0738	2.72		<b>Shallow Concentrated Flow,</b> Nearly Bare & Untilled Kv= 10.0 fps
0.2	113	0.0088	9.20	322.06	<b>Channel Flow,</b> Area= 35.0 sf Perim= 20.0' r= 1.75' n= 0.022 Earth, clean & straight
9.2	1,112	Total			

**Subcatchment P3: P-SB-3**

Hydrograph

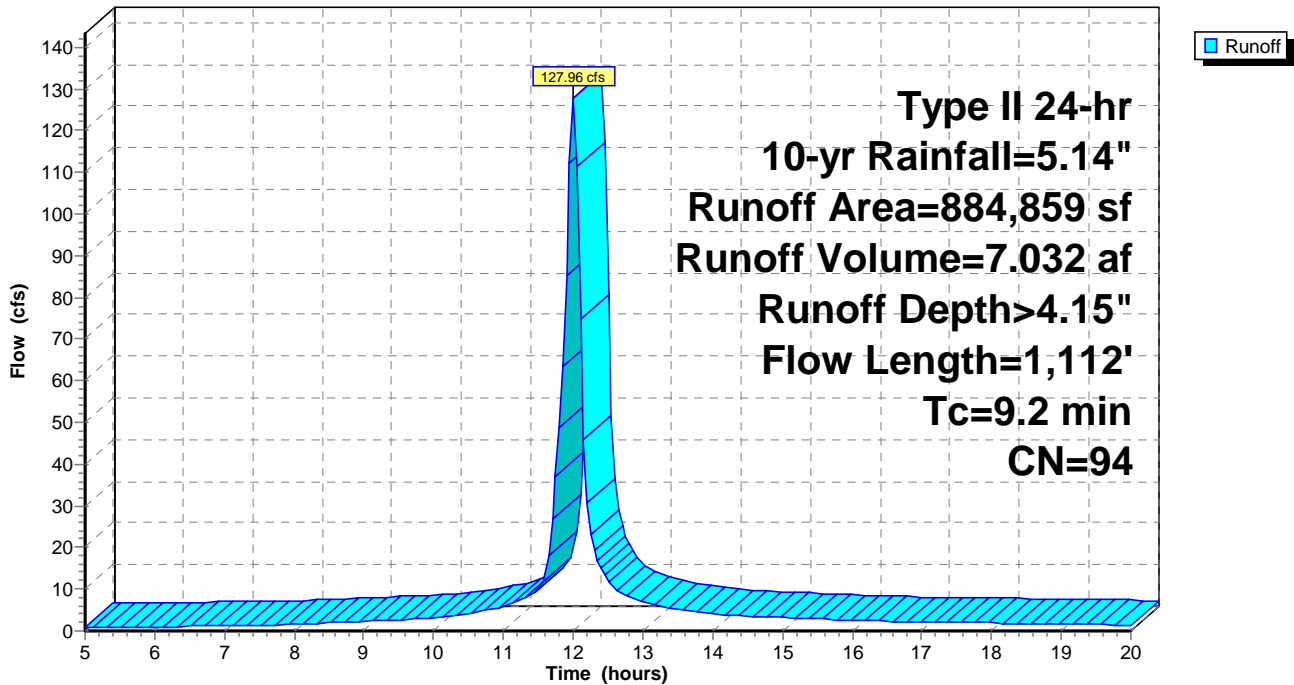

**210730C\_I77\_SEDIMENT\_BASINS**

Prepared by S&ME, Inc.

HydroCAD® 10.00-26 s/n 06707 © 2020 HydroCAD Software Solutions LLC

Type II 24-hr 10-yr Rainfall=5.14"

Printed 3/18/2021

Page 45

**Summary for Subcatchment PT1: PT-SB-1**

No Channel Flow

Runoff = 135.91 cfs @ 12.03 hrs, Volume= 8.043 af, Depth> 4.15"

Runoff by SCS TR-20 method, UH=SCS, Weighted-CN, Time Span= 5.00-20.00 hrs, dt= 0.05 hrs  
Type II 24-hr 10-yr Rainfall=5.14"

Area (sf)	CN	Description
1,012,355	94	Newly graded area, HSG D
1,012,355		100.00% Pervious Area

Tc (min)	Length (feet)	Slope (ft/ft)	Velocity (ft/sec)	Capacity (cfs)	Description
6.2	300	0.0546	0.80		<b>Sheet Flow,</b> Fallow n= 0.050 P2= 3.54"
5.3	804	0.0630	2.51		<b>Shallow Concentrated Flow,</b> Nearly Bare & Untilled Kv= 10.0 fps
11.5	1,104	Total			

**Subcatchment PT1: PT-SB-1**

Hydrograph

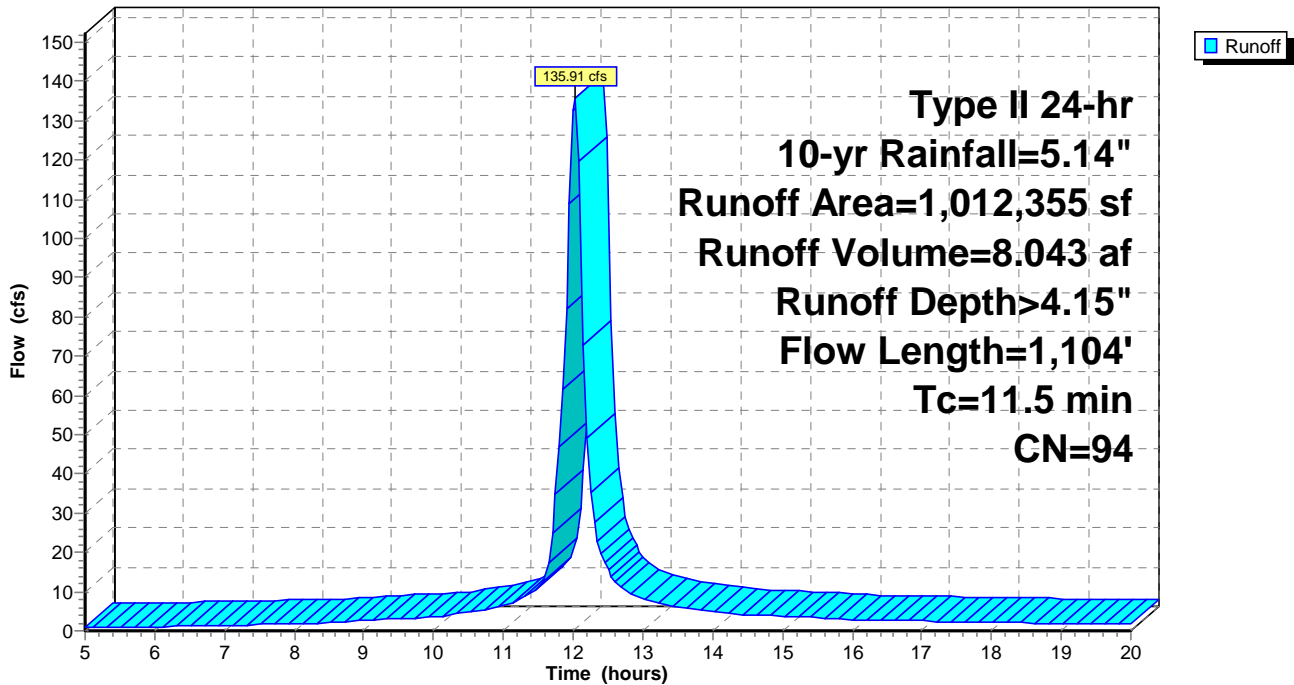

**210730C\_I77\_SEDIMENT\_BASINS**

Prepared by S&ME, Inc.

HydroCAD® 10.00-26 s/n 06707 © 2020 HydroCAD Software Solutions LLC

Type II 24-hr 10-yr Rainfall=5.14"

Printed 3/18/2021

Page 46

**Summary for Subcatchment W1: W-SB-1**

Runoff = 90.38 cfs @ 11.99 hrs, Volume= 4.768 af, Depth> 4.15"

Runoff by SCS TR-20 method, UH=SCS, Weighted-CN, Time Span= 5.00-20.00 hrs, dt= 0.05 hrs  
 Type II 24-hr 10-yr Rainfall=5.14"

Area (sf)	CN	Description
599,872	94	Newly graded area, HSG D
599,872		100.00% Pervious Area

Tc (min)	Length (feet)	Slope (ft/ft)	Velocity (ft/sec)	Capacity (cfs)	Description
5.6	300	0.0707	0.89		<b>Sheet Flow,</b> Fallow n= 0.050 P2= 3.54"
1.6	334	0.1196	3.46		<b>Shallow Concentrated Flow,</b> Nearly Bare & Untilled Kv= 10.0 fps
0.7	559	0.0190	13.52	473.22	<b>Channel Flow,</b> Area= 35.0 sf Perim= 20.0' r= 1.75' n= 0.022 Earth, clean & straight
7.9	1,193	Total			

**Subcatchment W1: W-SB-1**

Hydrograph

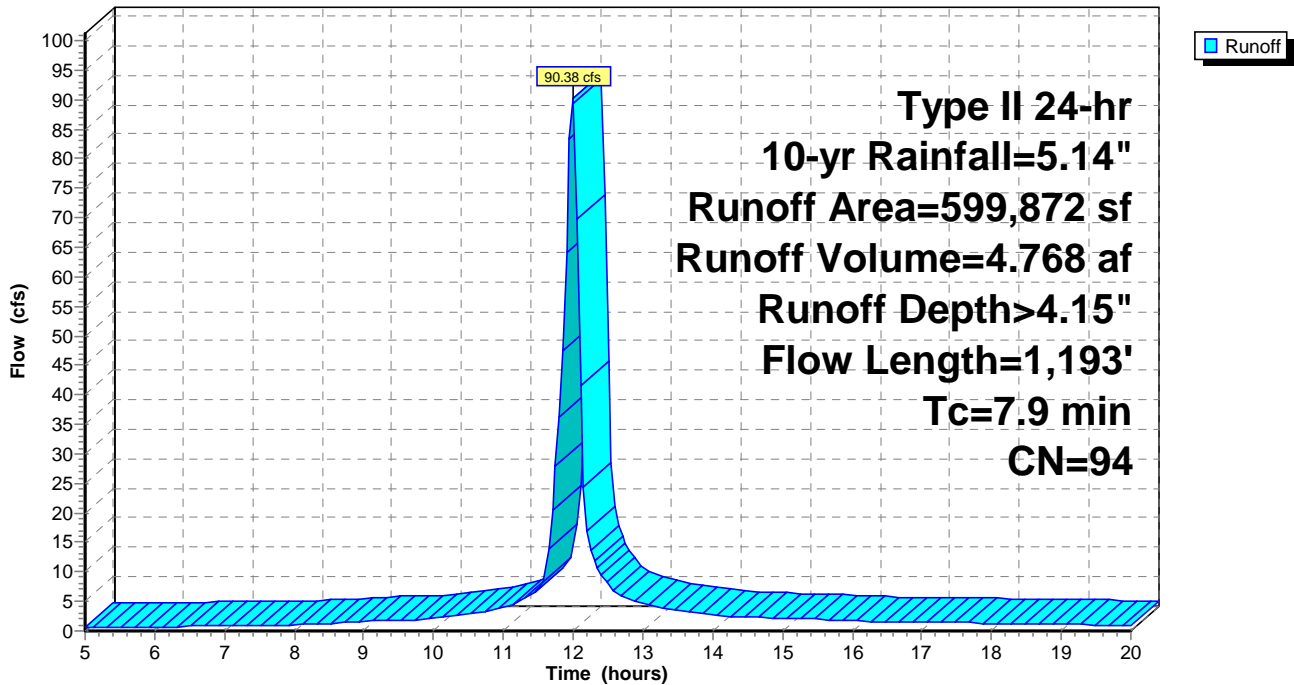

**210730C\_I77\_SEDIMENT\_BASINS**

Type II 24-hr 10-yr Rainfall=5.14"

Prepared by S&ME, Inc.

Printed 3/18/2021

HydroCAD® 10.00-26 s/n 06707 © 2020 HydroCAD Software Solutions LLC

Page 47

**Summary for Pond 1P: P-PT-SB-1**

[82] Warning: Early inflow requires earlier time span

Inflow Area = 23.240 ac, 0.00% Impervious, Inflow Depth > 4.15" for 10-yr event  
 Inflow = 135.91 cfs @ 12.03 hrs, Volume= 8.043 af  
 Outflow = 1.17 cfs @ 9.60 hrs, Volume= 1.151 af, Atten= 99%, Lag= 0.0 min  
 Primary = 1.17 cfs @ 9.60 hrs, Volume= 1.151 af  
 Secondary = 0.00 cfs @ 5.00 hrs, Volume= 0.000 af

Routing by Stor-Ind method, Time Span= 5.00-20.00 hrs, dt= 0.05 hrs  
 Peak Elev= 562.68' @ 20.00 hrs Surf.Area= 62,870 sf Storage= 300,166 cf

Plug-Flow detention time= 301.8 min calculated for 1.146 af (14% of inflow)  
 Center-of-Mass det. time= 95.3 min ( 841.1 - 745.8 )

Volume	Invert	Avail.Storage	Storage Description
#1	557.00'	455,428 cf	<b>Custom Stage Data (Prismatic)</b> Listed below (Recalc)

Elevation (feet)	Surf.Area (sq-ft)	Inc.Store (cubic-feet)	Cum.Store (cubic-feet)
557.00	42,794	0	0
565.00	71,063	455,428	455,428

Device	Routing	Invert	Outlet Devices
#1	Device 2	557.00'	<b>1.168 cfs Constant Flow/Skimmer</b>
#2	Primary	557.00'	<b>24.0" Round Culvert</b> L= 100.0' CMP, square edge headwall, Ke= 0.500 Inlet / Outlet Invert= 557.00' / 556.00' S= 0.0100 '/' Cc= 0.900 n= 0.012 Concrete pipe, finished, Flow Area= 3.14 sf
#3	Device 2	562.70'	<b>36.0" x 36.0" Horiz. Orifice/Grate</b> C= 0.600 Limited to weir flow at low heads
#4	Secondary	563.70'	<b>20.0' long x 12.0' breadth Broad-Crested Rectangular Weir</b> Head (feet) 0.20 0.40 0.60 0.80 1.00 1.20 1.40 1.60 Coef. (English) 2.57 2.62 2.70 2.67 2.66 2.67 2.66 2.64

**Primary OutFlow** Max=1.17 cfs @ 9.60 hrs HW=557.48' (Free Discharge)  
 ↑ **2=Culvert** (Passes 1.17 cfs of 1.38 cfs potential flow)  
 ↑ **1=Constant Flow/Skimmer** (Constant Controls 1.17 cfs)  
 ↑ **3=Orifice/Grate** ( Controls 0.00 cfs)

**Secondary OutFlow** Max=0.00 cfs @ 5.00 hrs HW=557.00' (Free Discharge)  
 ↑ **4=Broad-Crested Rectangular Weir** ( Controls 0.00 cfs)



Pond 1P: P-PT-SB-1

Hydrograph

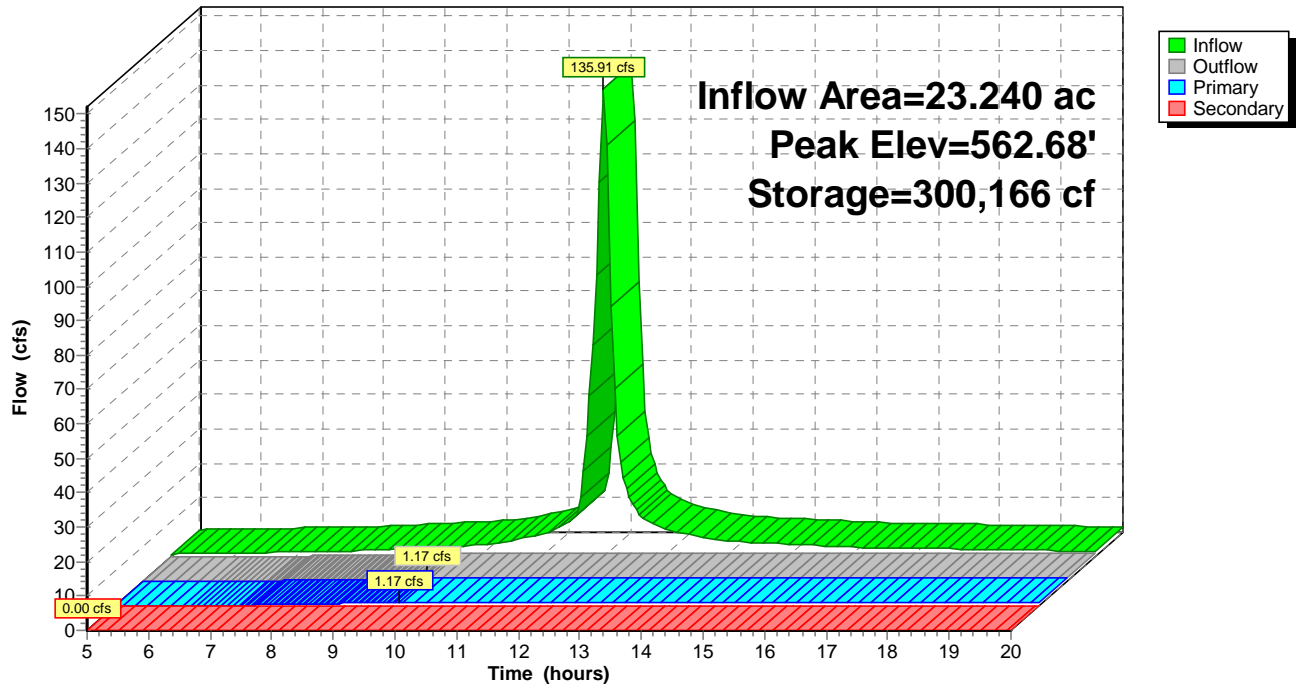

**Summary for Pond 2P: P-W-SB-1**

[82] Warning: Early inflow requires earlier time span

Inflow Area = 13.771 ac, 0.00% Impervious, Inflow Depth > 4.15" for 10-yr event  
 Inflow = 90.38 cfs @ 11.99 hrs, Volume= 4.768 af  
 Outflow = 0.89 cfs @ 9.35 hrs, Volume= 0.895 af, Atten= 99%, Lag= 0.0 min  
 Primary = 0.89 cfs @ 9.35 hrs, Volume= 0.895 af  
 Secondary = 0.00 cfs @ 5.00 hrs, Volume= 0.000 af

Routing by Stor-Ind method, Time Span= 5.00-20.00 hrs, dt= 0.05 hrs  
 Peak Elev= 505.39' @ 20.00 hrs Surf.Area= 37,563 sf Storage= 168,705 cf

Plug-Flow detention time= 265.3 min calculated for 0.891 af (19% of inflow)  
 Center-of-Mass det. time= 92.4 min ( 835.4 - 743.1 )

Volume	Invert	Avail.Storage	Storage Description
#1	500.00'	274,756 cf	<b>Custom Stage Data (Prismatic)</b> Listed below (Recalc)

Elevation (feet)	Surf.Area (sq-ft)	Inc.Store (cubic-feet)	Cum.Store (cubic-feet)
500.00	25,066	0	0
508.00	43,623	274,756	274,756

Device	Routing	Invert	Outlet Devices
#1	Device 2	500.00'	<b>0.894 cfs Constant Flow/Skimmer</b>
#2	Primary	500.00'	<b>24.0" Round Culvert</b> L= 100.0' CMP, square edge headwall, Ke= 0.500 Inlet / Outlet Invert= 500.00' / 499.00' S= 0.0100 '/' Cc= 0.900 n= 0.012 Concrete pipe, finished, Flow Area= 3.14 sf
#3	Device 2	505.40'	<b>36.0" x 36.0" Horiz. Orifice/Grate</b> C= 0.600 Limited to weir flow at low heads
#4	Secondary	506.40'	<b>20.0' long x 12.0' breadth Broad-Crested Rectangular Weir</b> Head (feet) 0.20 0.40 0.60 0.80 1.00 1.20 1.40 1.60 Coef. (English) 2.57 2.62 2.70 2.67 2.66 2.67 2.66 2.64

**Primary OutFlow** Max=0.89 cfs @ 9.35 hrs HW=500.40' (Free Discharge)  
 ↑ **2=Culvert** (Passes 0.89 cfs of 0.97 cfs potential flow)  
 ↑ **1=Constant Flow/Skimmer** (Constant Controls 0.89 cfs)  
 ↑ **3=Orifice/Grate** ( Controls 0.00 cfs)

**Secondary OutFlow** Max=0.00 cfs @ 5.00 hrs HW=500.00' (Free Discharge)  
 ↑ **4=Broad-Crested Rectangular Weir** ( Controls 0.00 cfs)

Pond 2P: P-W-SB-1

Hydrograph

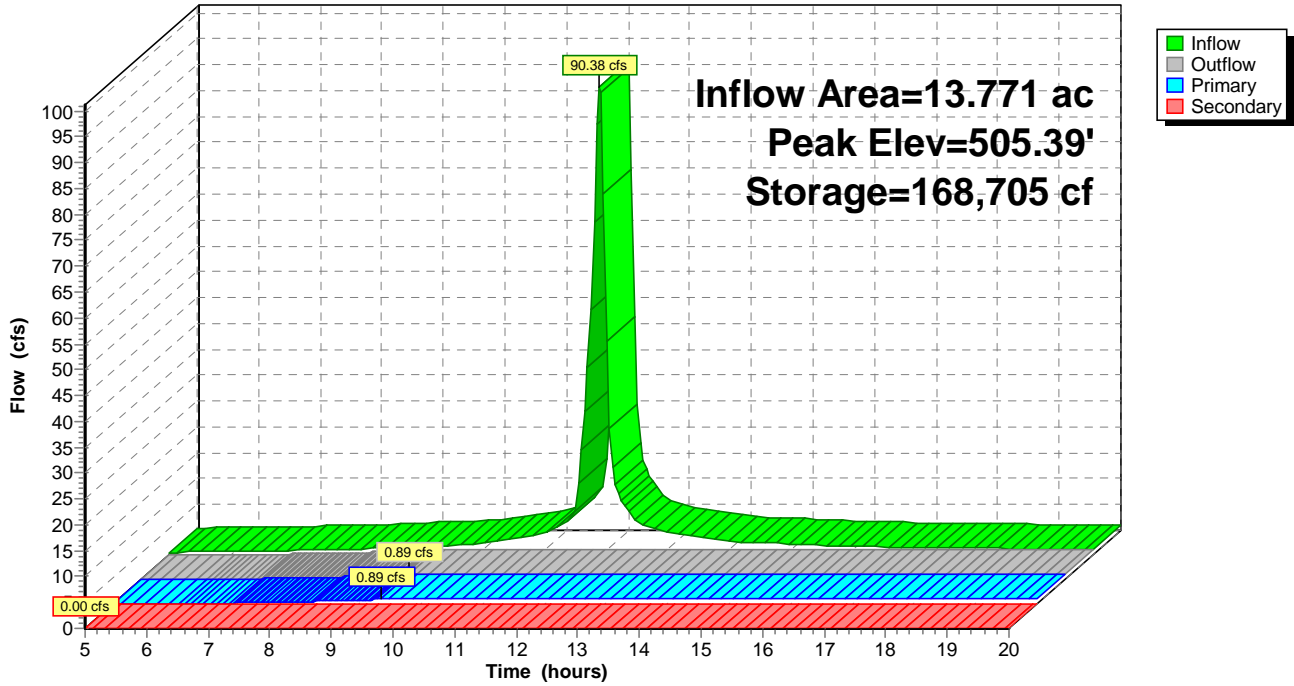

**210730C\_I77\_SEDIMENT\_BASINS**

Type II 24-hr 10-yr Rainfall=5.14"

Prepared by S&ME, Inc.

Printed 3/18/2021

HydroCAD® 10.00-26 s/n 06707 © 2020 HydroCAD Software Solutions LLC

Page 51

**Summary for Pond 3P: P-P-SB-1**

[82] Warning: Early inflow requires earlier time span

Inflow Area = 44.467 ac, 0.00% Impervious, Inflow Depth > 4.15" for 10-yr event  
 Inflow = 241.19 cfs @ 12.05 hrs, Volume= 15.383 af  
 Outflow = 2.34 cfs @ 9.90 hrs, Volume= 2.268 af, Atten= 99%, Lag= 0.0 min  
 Primary = 2.34 cfs @ 9.90 hrs, Volume= 2.268 af  
 Secondary = 0.00 cfs @ 5.00 hrs, Volume= 0.000 af

Routing by Stor-Ind method, Time Span= 5.00-20.00 hrs, dt= 0.05 hrs  
 Peak Elev= 457.36' @ 20.00 hrs Surf.Area= 93,486 sf Storage= 571,220 cf

Plug-Flow detention time= 301.6 min calculated for 2.258 af (15% of inflow)  
 Center-of-Mass det. time= 98.4 min ( 846.2 - 747.8 )

Volume	Invert	Avail.Storage	Storage Description
#1	450.00'	832,615 cf	<b>Custom Stage Data (Prismatic)</b> Listed below (Recalc)

Elevation (feet)	Surf.Area (sq-ft)	Inc.Store (cubic-feet)	Cum.Store (cubic-feet)
450.00	61,641	0	0
460.00	104,882	832,615	832,615

Device	Routing	Invert	Outlet Devices
#1	Device 2	450.00'	<b>1.168 cfs Constant Flow/Skimmer X 2.00</b>
#2	Primary	450.00'	<b>24.0" Round Culvert</b> L= 100.0' CMP, square edge headwall, Ke= 0.500 Inlet / Outlet Invert= 450.00' / 449.00' S= 0.0100 '/' Cc= 0.900 n= 0.012 Concrete pipe, finished, Flow Area= 3.14 sf
#3	Device 2	457.40'	<b>36.0" x 36.0" Horiz. Orifice/Grate</b> C= 0.600 Limited to weir flow at low heads
#4	Secondary	458.40'	<b>20.0' long x 12.0' breadth Broad-Crested Rectangular Weir</b> Head (feet) 0.20 0.40 0.60 0.80 1.00 1.20 1.40 1.60 Coef. (English) 2.57 2.62 2.70 2.67 2.66 2.67 2.66 2.64

**Primary OutFlow** Max=2.34 cfs @ 9.90 hrs HW=450.71' (Free Discharge)  
 ↑ **2=Culvert** (Passes 2.34 cfs of 2.83 cfs potential flow)  
 ↑ **1=Constant Flow/Skimmer** (Constant Controls 2.34 cfs)  
 ↑ **3=Orifice/Grate** ( Controls 0.00 cfs)

**Secondary OutFlow** Max=0.00 cfs @ 5.00 hrs HW=450.00' (Free Discharge)  
 ↑ **4=Broad-Crested Rectangular Weir** ( Controls 0.00 cfs)

Pond 3P: P-P-SB-1

Hydrograph

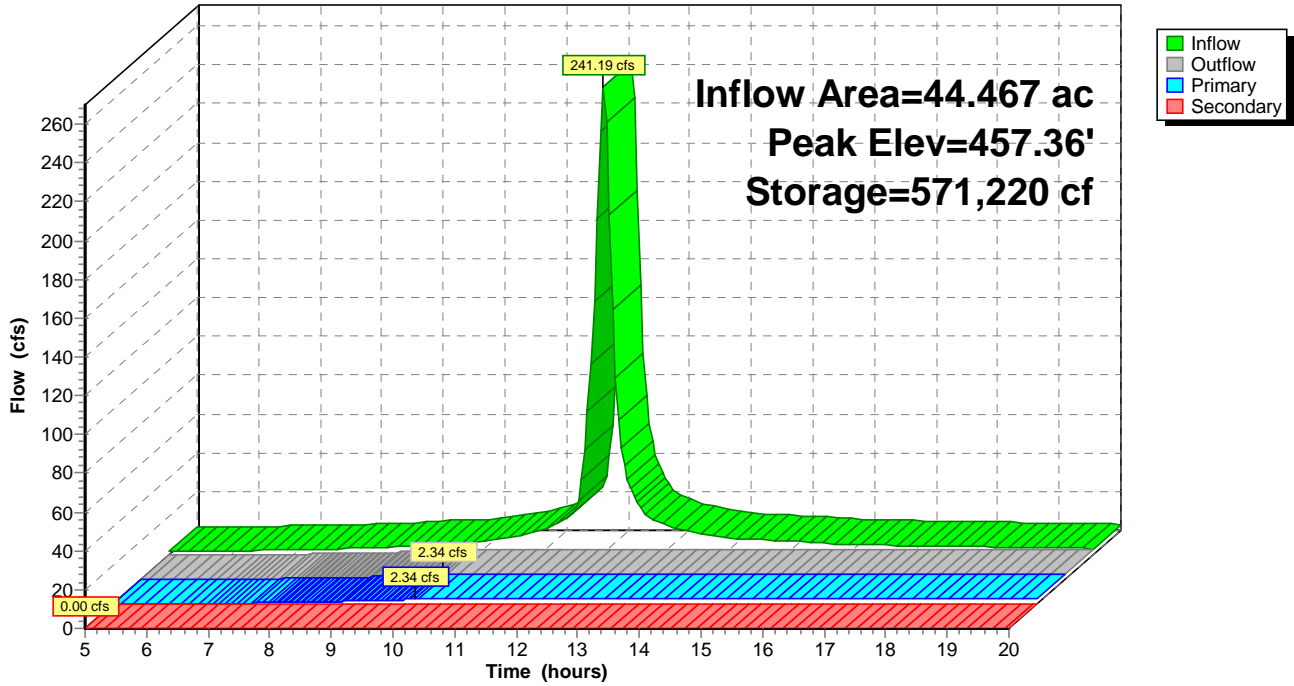

**Summary for Pond 4P: P-P-SB-2**

[82] Warning: Early inflow requires earlier time span

Inflow Area = 13.844 ac, 0.00% Impervious, Inflow Depth > 4.15" for 10-yr event  
 Inflow = 89.23 cfs @ 11.99 hrs, Volume= 4.793 af  
 Outflow = 0.89 cfs @ 9.30 hrs, Volume= 0.925 af, Atten= 99%, Lag= 0.0 min  
 Primary = 0.89 cfs @ 9.30 hrs, Volume= 0.925 af  
 Secondary = 0.00 cfs @ 5.00 hrs, Volume= 0.000 af

Routing by Stor-Ind method, Time Span= 5.00-20.00 hrs, dt= 0.05 hrs  
 Peak Elev= 487.37' @ 20.00 hrs Surf.Area= 33,956 sf Storage= 168,475 cf

Plug-Flow detention time= 250.4 min calculated for 0.924 af (19% of inflow)  
 Center-of-Mass det. time= 79.9 min ( 823.5 - 743.5 )

Volume	Invert	Avail.Storage	Storage Description
#1	481.00'	266,076 cf	<b>Custom Stage Data (Prismatic)</b> Listed below (Recalc)

Elevation (feet)	Surf.Area (sq-ft)	Inc.Store (cubic-feet)	Cum.Store (cubic-feet)
481.00	18,972	0	0
490.00	40,156	266,076	266,076

Device	Routing	Invert	Outlet Devices
#1	Device 2	481.00'	<b>0.894 cfs Constant Flow/Skimmer</b>
#2	Primary	481.00'	<b>24.0" Round Culvert</b> L= 100.0' CMP, square edge headwall, Ke= 0.500 Inlet / Outlet Invert= 481.00' / 480.00' S= 0.0100 '/' Cc= 0.900 n= 0.012 Concrete pipe, finished, Flow Area= 3.14 sf
#3	Device 2	487.40'	<b>36.0" x 36.0" Horiz. Orifice/Grate</b> C= 0.600 Limited to weir flow at low heads
#4	Secondary	488.40'	<b>20.0' long x 12.0' breadth Broad-Crested Rectangular Weir</b> Head (feet) 0.20 0.40 0.60 0.80 1.00 1.20 1.40 1.60 Coef. (English) 2.57 2.62 2.70 2.67 2.66 2.67 2.66 2.64

**Primary OutFlow** Max=0.89 cfs @ 9.30 hrs HW=481.45' (Free Discharge)  
 ↑ **2=Culvert** (Passes 0.89 cfs of 1.23 cfs potential flow)  
 ↑ **1=Constant Flow/Skimmer** (Constant Controls 0.89 cfs)  
 ↑ **3=Orifice/Grate** ( Controls 0.00 cfs)

**Secondary OutFlow** Max=0.00 cfs @ 5.00 hrs HW=481.00' (Free Discharge)  
 ↑ **4=Broad-Crested Rectangular Weir** ( Controls 0.00 cfs)

Pond 4P: P-P-SB-2

Hydrograph

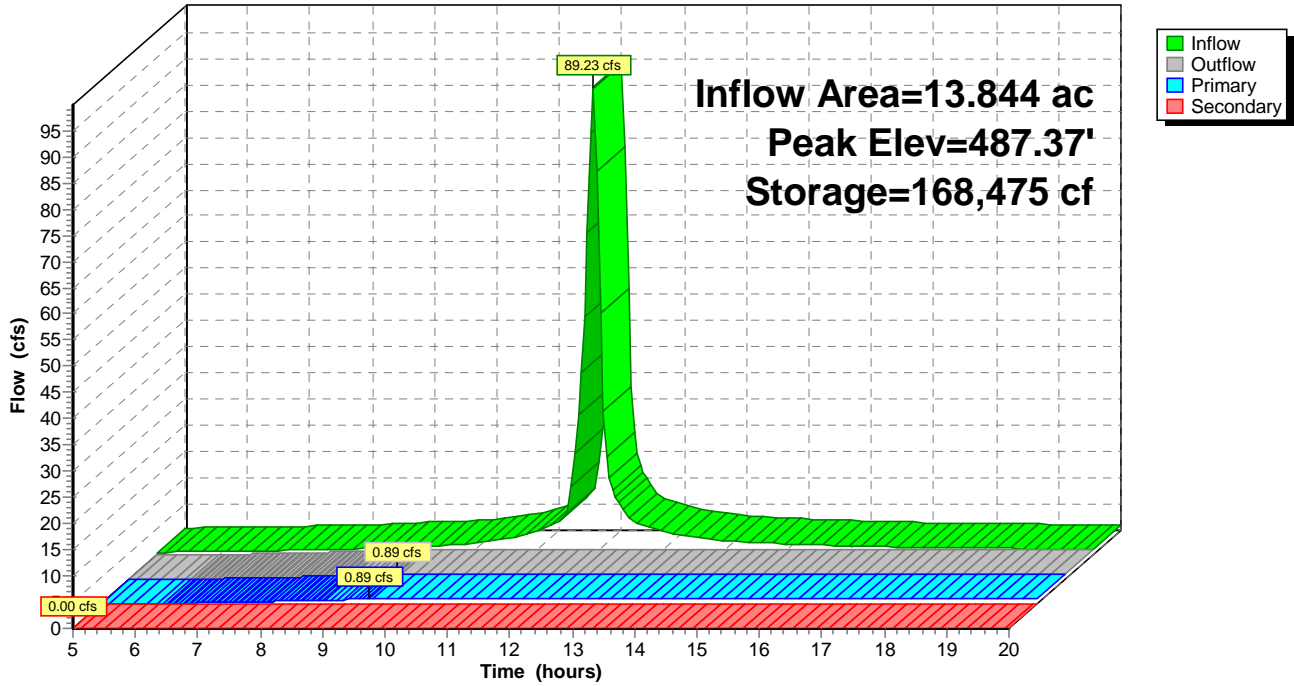

**Summary for Pond 5P: P-P-SB-3**

[82] Warning: Early inflow requires earlier time span

Inflow Area = 20.314 ac, 0.00% Impervious, Inflow Depth > 4.15" for 10-yr event  
 Inflow = 127.96 cfs @ 12.00 hrs, Volume= 7.032 af  
 Outflow = 1.17 cfs @ 9.10 hrs, Volume= 1.210 af, Atten= 99%, Lag= 0.0 min  
 Primary = 1.17 cfs @ 9.10 hrs, Volume= 1.210 af  
 Secondary = 0.00 cfs @ 5.00 hrs, Volume= 0.000 af

Routing by Stor-Ind method, Time Span= 5.00-20.00 hrs, dt= 0.05 hrs  
 Peak Elev= 497.29' @ 20.00 hrs Surf.Area= 44,566 sf Storage= 253,602 cf

Plug-Flow detention time= 263.6 min calculated for 1.209 af (17% of inflow)  
 Center-of-Mass det. time= 79.2 min ( 823.3 - 744.1 )

Volume	Invert	Avail.Storage	Storage Description
#1	490.00'	383,995 cf	<b>Custom Stage Data (Prismatic)</b> Listed below (Recalc)

Elevation (feet)	Surf.Area (sq-ft)	Inc.Store (cubic-feet)	Cum.Store (cubic-feet)
490.00	24,964	0	0
500.00	51,835	383,995	383,995

Device	Routing	Invert	Outlet Devices
#1	Device 2	490.00'	<b>1.168 cfs Constant Flow/Skimmer</b>
#2	Primary	490.00'	<b>24.0" Round Culvert</b> L= 100.0' CMP, square edge headwall, Ke= 0.500 Inlet / Outlet Invert= 490.00' / 489.00' S= 0.0100 '/' Cc= 0.900 n= 0.012 Concrete pipe, finished, Flow Area= 3.14 sf
#3	Device 2	497.30'	<b>36.0" x 36.0" Horiz. Orifice/Grate</b> C= 0.600 Limited to weir flow at low heads
#4	Secondary	498.30'	<b>20.0' long x 12.0' breadth Broad-Crested Rectangular Weir</b> Head (feet) 0.20 0.40 0.60 0.80 1.00 1.20 1.40 1.60 Coef. (English) 2.57 2.62 2.70 2.67 2.66 2.67 2.66 2.64

**Primary OutFlow** Max=1.17 cfs @ 9.10 hrs HW=490.50' (Free Discharge)  
 ↑ **2=Culvert** (Passes 1.17 cfs of 1.48 cfs potential flow)  
 ↑ **1=Constant Flow/Skimmer** (Constant Controls 1.17 cfs)  
 ↑ **3=Orifice/Grate** ( Controls 0.00 cfs)

**Secondary OutFlow** Max=0.00 cfs @ 5.00 hrs HW=490.00' (Free Discharge)  
 ↑ **4=Broad-Crested Rectangular Weir** ( Controls 0.00 cfs)



Pond 5P: P-P-SB-3

Hydrograph

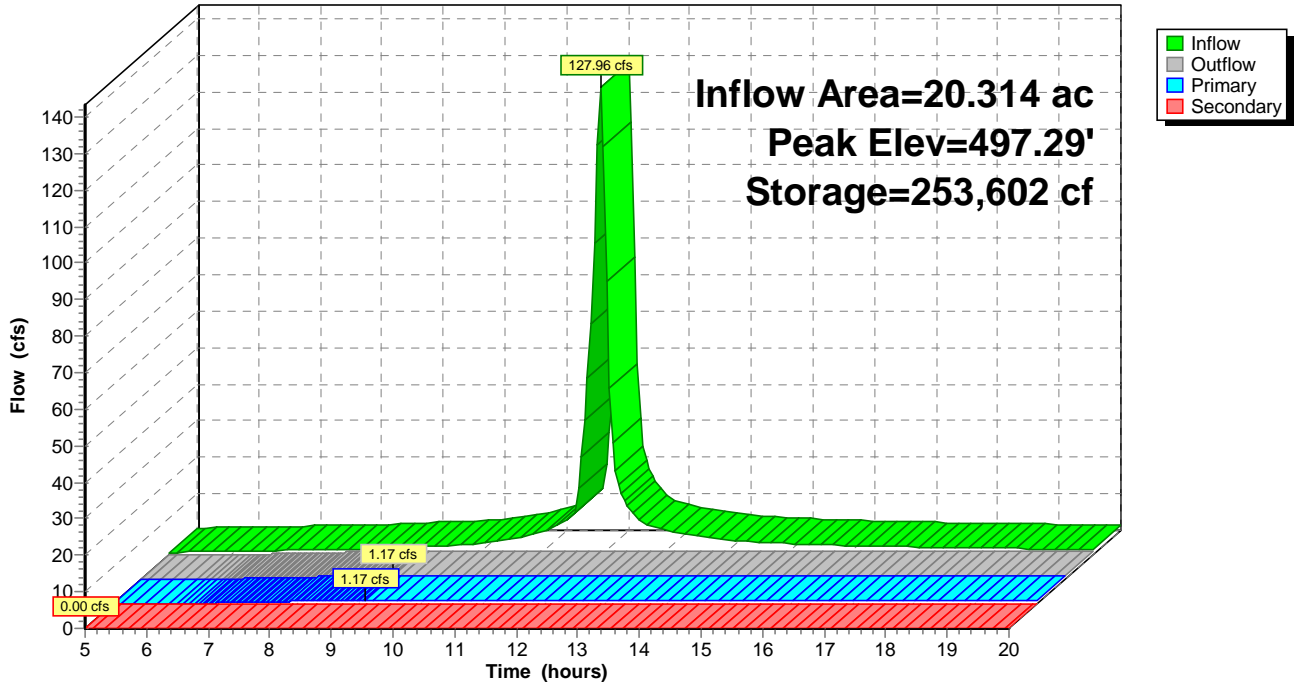

**Summary for Pond 6P: P-NE-SB-1**

[82] Warning: Early inflow requires earlier time span

Inflow Area = 20.801 ac, 0.00% Impervious, Inflow Depth > 4.15" for 10-yr event  
 Inflow = 127.97 cfs @ 12.01 hrs, Volume= 7.200 af  
 Outflow = 1.17 cfs @ 9.05 hrs, Volume= 1.216 af, Atten= 99%, Lag= 0.0 min  
 Primary = 1.17 cfs @ 9.05 hrs, Volume= 1.216 af  
 Secondary = 0.00 cfs @ 5.00 hrs, Volume= 0.000 af

Routing by Stor-Ind method, Time Span= 5.00-20.00 hrs, dt= 0.05 hrs  
 Peak Elev= 434.36' @ 20.00 hrs Surf.Area= 46,414 sf Storage= 260,626 cf

Plug-Flow detention time= 263.4 min calculated for 1.215 af (17% of inflow)  
 Center-of-Mass det. time= 76.7 min ( 821.3 - 744.6 )

Volume	Invert	Avail.Storage	Storage Description
#1	427.00'	393,720 cf	<b>Custom Stage Data (Prismatic)</b> Listed below (Recalc)

Elevation (feet)	Surf.Area (sq-ft)	Inc.Store (cubic-feet)	Cum.Store (cubic-feet)
427.00	24,435	0	0
437.00	54,309	393,720	393,720

Device	Routing	Invert	Outlet Devices
#1	Device 2	427.00'	<b>1.168 cfs Constant Flow/Skimmer</b>
#2	Primary	427.00'	<b>24.0" Round Culvert</b> L= 100.0' CMP, square edge headwall, Ke= 0.500 Inlet / Outlet Invert= 427.00' / 426.00' S= 0.0100 '/' Cc= 0.900 n= 0.012 Concrete pipe, finished, Flow Area= 3.14 sf
#3	Device 2	434.40'	<b>36.0" x 36.0" Horiz. Orifice/Grate</b> C= 0.600 Limited to weir flow at low heads
#4	Secondary	435.40'	<b>20.0' long x 12.0' breadth Broad-Crested Rectangular Weir</b> Head (feet) 0.20 0.40 0.60 0.80 1.00 1.20 1.40 1.60 Coef. (English) 2.57 2.62 2.70 2.67 2.66 2.67 2.66 2.64

**Primary OutFlow** Max=1.17 cfs @ 9.05 hrs HW=427.50' (Free Discharge)  
 ↑ **2=Culvert** (Passes 1.17 cfs of 1.50 cfs potential flow)  
 ↑ **1=Constant Flow/Skimmer** (Constant Controls 1.17 cfs)  
 ↑ **3=Orifice/Grate** ( Controls 0.00 cfs)

**Secondary OutFlow** Max=0.00 cfs @ 5.00 hrs HW=427.00' (Free Discharge)  
 ↑ **4=Broad-Crested Rectangular Weir** ( Controls 0.00 cfs)

### Pond 6P: P-NE-SB-1

#### Hydrograph

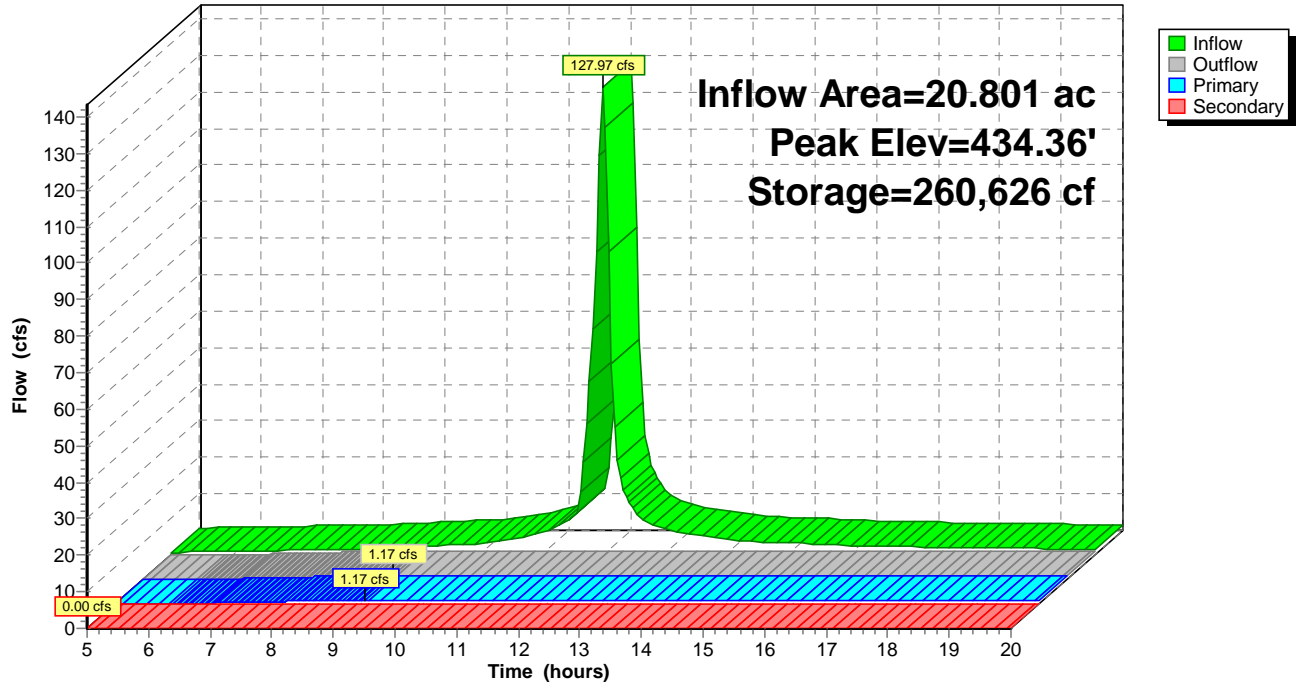

**210730C\_I77\_SEDIMENT\_BASINS**

Type II 24-hr 10-yr Rainfall=5.14"

Prepared by S&ME, Inc.

Printed 3/18/2021

HydroCAD® 10.00-26 s/n 06707 © 2020 HydroCAD Software Solutions LLC

Page 59

**Summary for Pond 7P: P-NE-SB-2**

[82] Warning: Early inflow requires earlier time span

Inflow Area = 7.668 ac, 0.00% Impervious, Inflow Depth > 4.16" for 10-yr event  
 Inflow = 51.88 cfs @ 11.97 hrs, Volume= 2.655 af  
 Outflow = 0.66 cfs @ 10.00 hrs, Volume= 0.664 af, Atten= 99%, Lag= 0.0 min  
 Primary = 0.66 cfs @ 10.00 hrs, Volume= 0.664 af  
 Secondary = 0.00 cfs @ 5.00 hrs, Volume= 0.000 af

Routing by Stor-Ind method, Time Span= 5.00-20.00 hrs, dt= 0.05 hrs  
 Peak Elev= 416.75' @ 18.59 hrs Surf.Area= 23,109 sf Storage= 87,108 cf

Plug-Flow detention time= 231.0 min calculated for 0.664 af (25% of inflow)  
 Center-of-Mass det. time= 89.7 min ( 831.6 - 741.9 )

Volume	Invert	Avail.Storage	Storage Description
#1	412.00'	172,776 cf	<b>Custom Stage Data (Prismatic)</b> Listed below (Recalc)

Elevation (feet)	Surf.Area (sq-ft)	Inc.Store (cubic-feet)	Cum.Store (cubic-feet)
412.00	13,554	0	0
420.00	29,640	172,776	172,776

Device	Routing	Invert	Outlet Devices
#1	Device 2	412.00'	<b>0.657 cfs Constant Flow/Skimmer</b>
#2	Primary	412.00'	<b>24.0" Round Culvert</b> L= 100.0' CMP, square edge headwall, Ke= 0.500 Inlet / Outlet Invert= 412.00' / 411.00' S= 0.0100 '/' Cc= 0.900 n= 0.012 Concrete pipe, finished, Flow Area= 3.14 sf
#3	Device 2	416.80'	<b>36.0" x 36.0" Horiz. Orifice/Grate</b> C= 0.600 Limited to weir flow at low heads
#4	Secondary	417.80'	<b>20.0' long x 12.0' breadth Broad-Crested Rectangular Weir</b> Head (feet) 0.20 0.40 0.60 0.80 1.00 1.20 1.40 1.60 Coef. (English) 2.57 2.62 2.70 2.67 2.66 2.67 2.66 2.64

**Primary OutFlow** Max=0.66 cfs @ 10.00 hrs HW=412.40' (Free Discharge)  
 ↑ **2=Culvert** (Passes 0.66 cfs of 0.98 cfs potential flow)  
 ↑ **1=Constant Flow/Skimmer** (Constant Controls 0.66 cfs)  
 ↑ **3=Orifice/Grate** ( Controls 0.00 cfs)

**Secondary OutFlow** Max=0.00 cfs @ 5.00 hrs HW=412.00' (Free Discharge)  
 ↑ **4=Broad-Crested Rectangular Weir** ( Controls 0.00 cfs)

Pond 7P: P-NE-SB-2

Hydrograph

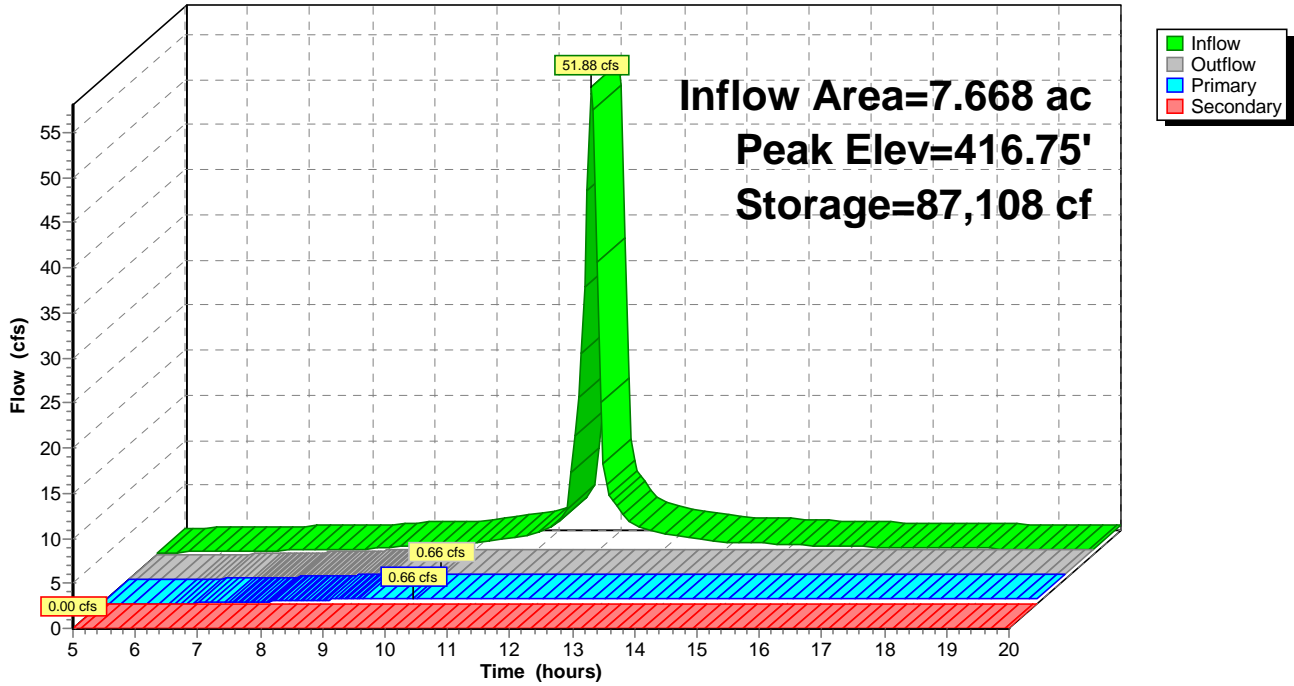

**210730C\_I77\_SEDIMENT\_BASINS**

Type II 24-hr 10-yr Rainfall=5.14"

Prepared by S&ME, Inc.

Printed 3/18/2021

HydroCAD® 10.00-26 s/n 06707 © 2020 HydroCAD Software Solutions LLC

Page 61

**Summary for Pond 8P: P-NE-SB-3**

[82] Warning: Early inflow requires earlier time span

Inflow Area = 10.129 ac, 0.00% Impervious, Inflow Depth > 4.16" for 10-yr event  
 Inflow = 67.89 cfs @ 11.98 hrs, Volume= 3.507 af  
 Outflow = 0.66 cfs @ 8.90 hrs, Volume= 0.691 af, Atten= 99%, Lag= 0.0 min  
 Primary = 0.66 cfs @ 8.90 hrs, Volume= 0.691 af  
 Secondary = 0.00 cfs @ 5.00 hrs, Volume= 0.000 af

Routing by Stor-Ind method, Time Span= 5.00-20.00 hrs, dt= 0.05 hrs  
 Peak Elev= 417.98' @ 20.00 hrs Surf.Area= 27,080 sf Storage= 122,681 cf

Plug-Flow detention time= 243.1 min calculated for 0.690 af (20% of inflow)  
 Center-of-Mass det. time= 75.1 min ( 817.6 - 742.5 )

Volume	Invert	Avail.Storage	Storage Description
#1	412.00'	214,574 cf	<b>Custom Stage Data (Prismatic)</b> Listed below (Recalc)

Elevation (feet)	Surf.Area (sq-ft)	Inc.Store (cubic-feet)	Cum.Store (cubic-feet)
412.00	13,973	0	0
421.00	33,710	214,574	214,574

Device	Routing	Invert	Outlet Devices
#1	Device 2	412.00'	<b>0.657 cfs Constant Flow/Skimmer</b>
#2	Primary	412.00'	<b>24.0" Round Culvert</b> L= 100.0' CMP, square edge headwall, Ke= 0.500 Inlet / Outlet Invert= 412.00' / 411.00' S= 0.0100 '/' Cc= 0.900 n= 0.012 Concrete pipe, finished, Flow Area= 3.14 sf
#3	Device 2	418.00'	<b>36.0" x 36.0" Horiz. Orifice/Grate</b> C= 0.600 Limited to weir flow at low heads
#4	Secondary	419.00'	<b>20.0' long x 12.0' breadth Broad-Crested Rectangular Weir</b> Head (feet) 0.20 0.40 0.60 0.80 1.00 1.20 1.40 1.60 Coef. (English) 2.57 2.62 2.70 2.67 2.66 2.67 2.66 2.64

**Primary OutFlow** Max=0.66 cfs @ 8.90 hrs HW=412.36' (Free Discharge)  
 ↑ **2=Culvert** (Passes 0.66 cfs of 0.80 cfs potential flow)  
 ↑ **1=Constant Flow/Skimmer** (Constant Controls 0.66 cfs)  
 ↑ **3=Orifice/Grate** ( Controls 0.00 cfs)

**Secondary OutFlow** Max=0.00 cfs @ 5.00 hrs HW=412.00' (Free Discharge)  
 ↑ **4=Broad-Crested Rectangular Weir** ( Controls 0.00 cfs)

Pond 8P: P-NE-SB-3

Hydrograph

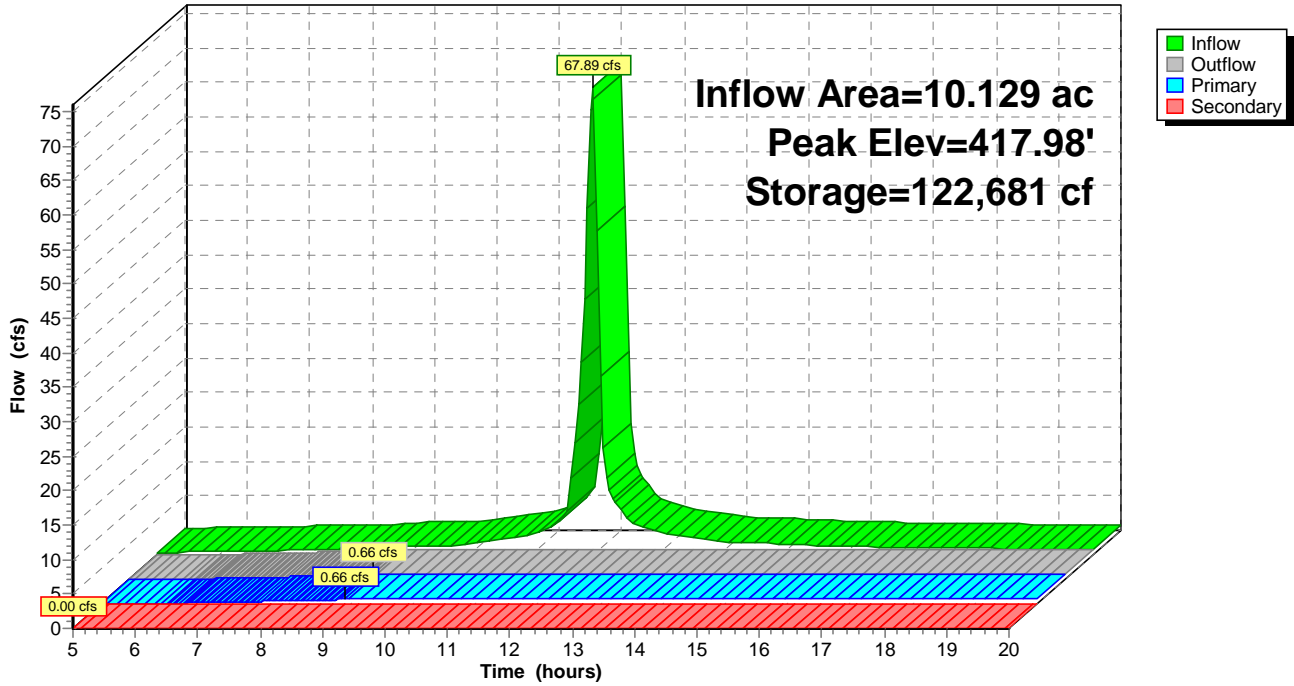

**210730C\_I77\_SEDIMENT\_BASINS**

Type II 24-hr 10-yr Rainfall=5.14"

Prepared by S&ME, Inc.

Printed 3/18/2021

HydroCAD® 10.00-26 s/n 06707 © 2020 HydroCAD Software Solutions LLC

Page 63

**Summary for Pond 9P: P-NE-SB-4**

[82] Warning: Early inflow requires earlier time span

Inflow Area = 15.592 ac, 0.00% Impervious, Inflow Depth > 4.15" for 10-yr event  
 Inflow = 100.49 cfs @ 11.99 hrs, Volume= 5.398 af  
 Outflow = 1.17 cfs @ 9.85 hrs, Volume= 1.145 af, Atten= 99%, Lag= 0.0 min  
 Primary = 1.17 cfs @ 9.85 hrs, Volume= 1.145 af  
 Secondary = 0.00 cfs @ 5.00 hrs, Volume= 0.000 af

Routing by Stor-Ind method, Time Span= 5.00-20.00 hrs, dt= 0.05 hrs  
 Peak Elev= 484.40' @ 19.47 hrs Surf.Area= 41,270 sf Storage= 185,391 cf

Plug-Flow detention time= 257.9 min calculated for 1.140 af (21% of inflow)  
 Center-of-Mass det. time= 99.2 min ( 842.7 - 743.5 )

Volume	Invert	Avail.Storage	Storage Description
#1	479.00'	301,356 cf	<b>Custom Stage Data (Prismatic)</b> Listed below (Recalc)

Elevation (feet)	Surf.Area (sq-ft)	Inc.Store (cubic-feet)	Cum.Store (cubic-feet)
479.00	27,386	0	0
487.00	47,953	301,356	301,356

Device	Routing	Invert	Outlet Devices
#1	Device 2	479.00'	<b>1.168 cfs Constant Flow/Skimmer</b>
#2	Primary	479.00'	<b>24.0" Round Culvert</b> L= 100.0' CMP, square edge headwall, Ke= 0.500 Inlet / Outlet Invert= 479.00' / 478.00' S= 0.0100 '/' Cc= 0.900 n= 0.012 Concrete pipe, finished, Flow Area= 3.14 sf
#3	Device 2	484.50'	<b>36.0" x 36.0" Horiz. Orifice/Grate</b> C= 0.600 Limited to weir flow at low heads
#4	Secondary	485.50'	<b>20.0' long x 12.0' breadth Broad-Crested Rectangular Weir</b> Head (feet) 0.20 0.40 0.60 0.80 1.00 1.20 1.40 1.60 Coef. (English) 2.57 2.62 2.70 2.67 2.66 2.67 2.66 2.64

**Primary OutFlow** Max=1.17 cfs @ 9.85 hrs HW=479.48' (Free Discharge)  
 ↑ **2=Culvert** (Passes 1.17 cfs of 1.37 cfs potential flow)  
 ↑ **1=Constant Flow/Skimmer** (Constant Controls 1.17 cfs)  
 ↑ **3=Orifice/Grate** ( Controls 0.00 cfs)

**Secondary OutFlow** Max=0.00 cfs @ 5.00 hrs HW=479.00' (Free Discharge)  
 ↑ **4=Broad-Crested Rectangular Weir** ( Controls 0.00 cfs)



**210730C\_I77\_SEDIMENT\_BASINS**

Prepared by S&ME, Inc.

HydroCAD® 10.00-26 s/n 06707 © 2020 HydroCAD Software Solutions LLC

Type II 24-hr 10-yr Rainfall=5.14"

Printed 3/18/2021

Page 64

**Pond 9P: P-NE-SB-4**

Hydrograph

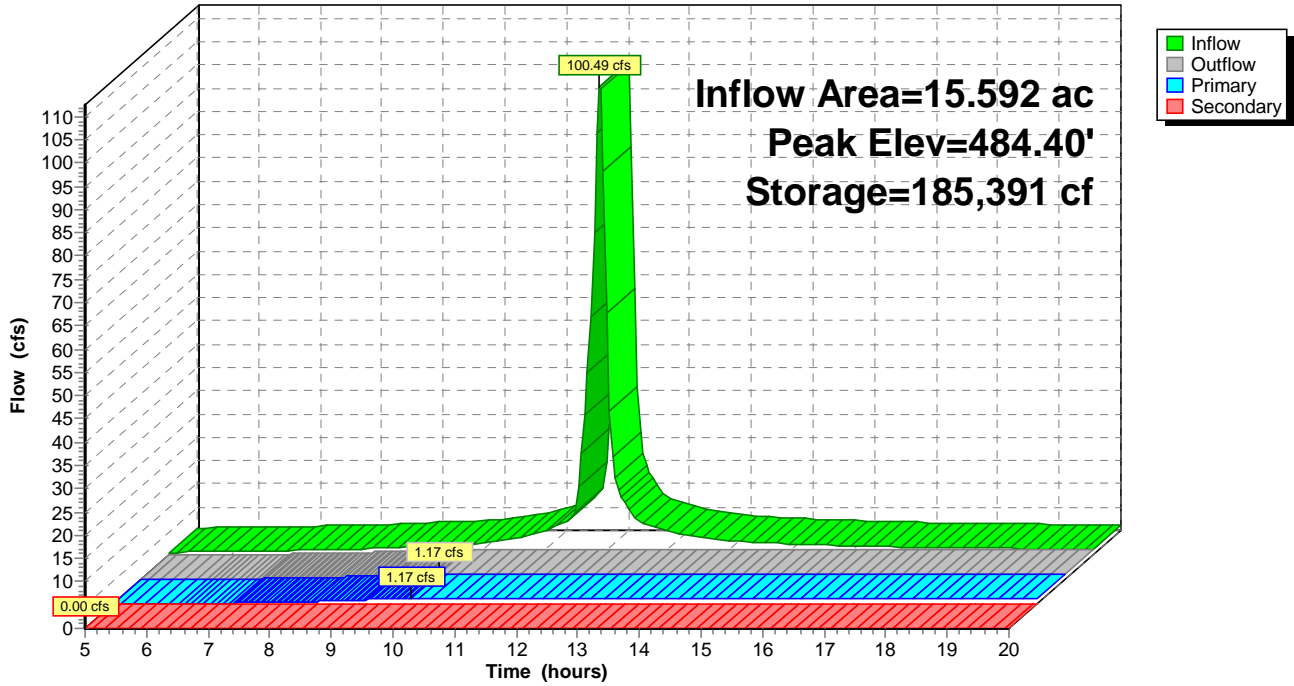

**210730C\_I77\_SEDIMENT\_BASINS**

Type II 24-hr 25-yr Rainfall=6.22"

Prepared by S&amp;ME, Inc.

Printed 3/18/2021

HydroCAD® 10.00-26 s/n 06707 © 2020 HydroCAD Software Solutions LLC

Page 65

Time span=5.00-20.00 hrs, dt=0.05 hrs, 301 points  
 Runoff by SCS TR-20 method, UH=SCS, Weighted-CN  
 Reach routing by Stor-Ind+Trans method - Pond routing by Stor-Ind method

<b>Subcatchment NE1: NE-SB-1</b>	Runoff Area=906,076 sf 0.00% Impervious Runoff Depth>5.14" Flow Length=990' Tc=9.9 min CN=94 Runoff=156.73 cfs 8.909 af
<b>Subcatchment NE2: NE-SB-2</b>	Runoff Area=334,011 sf 0.00% Impervious Runoff Depth>5.14" Flow Length=640' Tc=6.4 min CN=94 Runoff=63.51 cfs 3.285 af
<b>Subcatchment NE3: NE-SB-3</b>	Runoff Area=441,198 sf 0.00% Impervious Runoff Depth>5.14" Flow Length=840' Tc=7.1 min CN=94 Runoff=83.09 cfs 4.339 af
<b>Subcatchment NE4: NE-SB-4</b>	Runoff Area=679,173 sf 0.00% Impervious Runoff Depth>5.14" Flow Length=1,778' Tc=8.5 min CN=94 Runoff=123.04 cfs 6.679 af
<b>Subcatchment P1: P-SB-1</b>	Runoff Area=1,936,988 sf 0.00% Impervious Runoff Depth>5.14" Flow Length=1,935' Tc=14.1 min CN=94 Runoff=295.54 cfs 19.036 af
<b>Subcatchment P2: P-SB-2</b>	Runoff Area=603,049 sf 0.00% Impervious Runoff Depth>5.14" Flow Length=1,182' Tc=8.5 min CN=94 Runoff=109.25 cfs 5.930 af
<b>Subcatchment P3: P-SB-3</b>	Runoff Area=884,859 sf 0.00% Impervious Runoff Depth>5.14" Flow Length=1,112' Tc=9.2 min CN=94 Runoff=156.69 cfs 8.701 af
<b>Subcatchment PT1: PT-SB-1</b>	Runoff Area=1,012,355 sf 0.00% Impervious Runoff Depth>5.14" Flow Length=1,104' Tc=11.5 min CN=94 Runoff=166.47 cfs 9.952 af
<b>Subcatchment W1: W-SB-1</b>	Runoff Area=599,872 sf 0.00% Impervious Runoff Depth>5.14" Flow Length=1,193' Tc=7.9 min CN=94 Runoff=110.63 cfs 5.899 af
<b>Pond 1P: P-PT-SB-1</b>	Peak Elev=562.96' Storage=317,790 cf Inflow=166.47 cfs 9.952 af Primary=6.41 cfs 2.906 af Secondary=0.00 cfs 0.000 af Outflow=6.41 cfs 2.906 af
<b>Pond 2P: P-W-SB-1</b>	Peak Elev=505.62' Storage=177,440 cf Inflow=110.63 cfs 5.899 af Primary=4.93 cfs 1.978 af Secondary=0.00 cfs 0.000 af Outflow=4.93 cfs 1.978 af
<b>Pond 3P: P-P-SB-1</b>	Peak Elev=457.78' Storage=610,361 cf Inflow=295.54 cfs 19.036 af Primary=11.54 cfs 5.542 af Secondary=0.00 cfs 0.000 af Outflow=11.54 cfs 5.542 af
<b>Pond 4P: P-P-SB-2</b>	Peak Elev=487.62' Storage=177,201 cf Inflow=109.25 cfs 5.930 af Primary=5.03 cfs 2.006 af Secondary=0.00 cfs 0.000 af Outflow=5.03 cfs 2.006 af
<b>Pond 5P: P-P-SB-3</b>	Peak Elev=497.57' Storage=266,002 cf Inflow=156.69 cfs 8.701 af Primary=6.76 cfs 2.808 af Secondary=0.00 cfs 0.000 af Outflow=6.76 cfs 2.808 af
<b>Pond 6P: P-NE-SB-1</b>	Peak Elev=434.66' Storage=275,000 cf Inflow=156.73 cfs 8.909 af Primary=6.55 cfs 2.806 af Secondary=0.00 cfs 0.000 af Outflow=6.55 cfs 2.806 af
<b>Pond 7P: P-NE-SB-2</b>	Peak Elev=416.97' Storage=92,273 cf Inflow=63.51 cfs 3.285 af Primary=3.52 cfs 1.258 af Secondary=0.00 cfs 0.000 af Outflow=3.52 cfs 1.258 af

**210730C\_I77\_SEDIMENT\_BASINS**

*Type II 24-hr 25-yr Rainfall=6.22"*

Prepared by S&ME, Inc.

Printed 3/18/2021

HydroCAD® 10.00-26 s/n 06707 © 2020 HydroCAD Software Solutions LLC

Page 66

**Pond 8P: P-NE-SB-3**

Peak Elev=418.19' Storage=128,405 cf Inflow=83.09 cfs 4.339 af  
Primary=3.87 cfs 1.488 af Secondary=0.00 cfs 0.000 af Outflow=3.87 cfs 1.488 af

**Pond 9P: P-NE-SB-4**

Peak Elev=484.73' Storage=199,073 cf Inflow=123.04 cfs 6.679 af  
Primary=5.51 cfs 2.296 af Secondary=0.00 cfs 0.000 af Outflow=5.51 cfs 2.296 af

**Total Runoff Area = 169.825 ac Runoff Volume = 72.732 af Average Runoff Depth = 5.14"**  
**100.00% Pervious = 169.825 ac 0.00% Impervious = 0.000 ac**

**210730C\_I77\_SEDIMENT\_BASINS**

Prepared by S&ME, Inc.

HydroCAD® 10.00-26 s/n 06707 © 2020 HydroCAD Software Solutions LLC

Type II 24-hr 25-yr Rainfall=6.22"

Printed 3/18/2021

Page 67

**Summary for Subcatchment NE1: NE-SB-1**

Runoff = 156.73 cfs @ 12.01 hrs, Volume= 8.909 af, Depth> 5.14"

Runoff by SCS TR-20 method, UH=SCS, Weighted-CN, Time Span= 5.00-20.00 hrs, dt= 0.05 hrs  
Type II 24-hr 25-yr Rainfall=6.22"

Area (sf)	CN	Description
906,076	94	Newly graded area, HSG D
906,076		100.00% Pervious Area

Tc (min)	Length (feet)	Slope (ft/ft)	Velocity (ft/sec)	Capacity (cfs)	Description
6.7	300	0.0464	0.75		<b>Sheet Flow,</b> Fallow n= 0.050 P2= 3.54"
3.2	690	0.1262	3.55		<b>Shallow Concentrated Flow,</b> Nearly Bare & Untilled Kv= 10.0 fps
9.9	990	Total			

**Subcatchment NE1: NE-SB-1**

Hydrograph

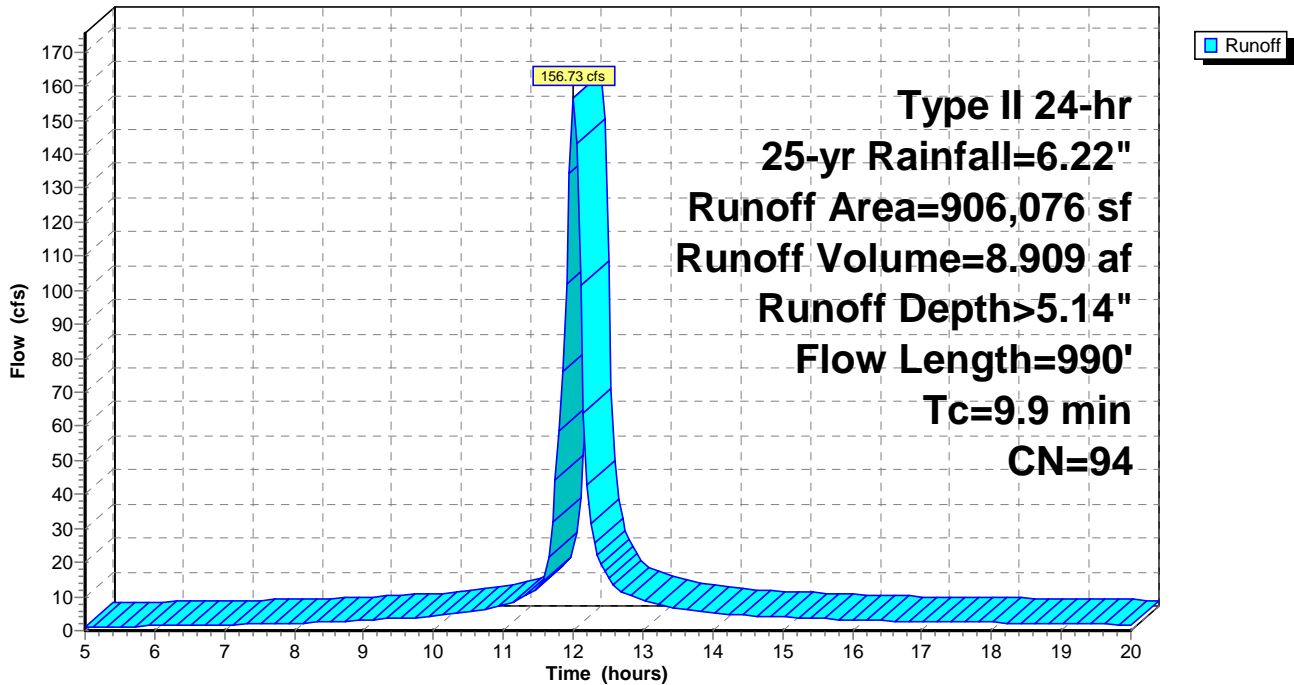

**210730C\_I77\_SEDIMENT\_BASINS**

Prepared by S&ME, Inc.

HydroCAD® 10.00-26 s/n 06707 © 2020 HydroCAD Software Solutions LLC

Type II 24-hr 25-yr Rainfall=6.22"

Printed 3/18/2021

Page 68

**Summary for Subcatchment NE2: NE-SB-2**

No Channel Flow

Runoff = 63.51 cfs @ 11.97 hrs, Volume= 3.285 af, Depth> 5.14"

Runoff by SCS TR-20 method, UH=SCS, Weighted-CN, Time Span= 5.00-20.00 hrs, dt= 0.05 hrs  
Type II 24-hr 25-yr Rainfall=6.22"

Area (sf)	CN	Description
334,011	94	Newly graded area, HSG D
334,011		100.00% Pervious Area

Tc (min)	Length (feet)	Slope (ft/ft)	Velocity (ft/sec)	Capacity (cfs)	Description
5.3	300	0.0812	0.94		<b>Sheet Flow,</b> Fallow n= 0.050 P2= 3.54"
1.1	340	0.2754	5.25		<b>Shallow Concentrated Flow,</b> Nearly Bare & Untilled Kv= 10.0 fps
6.4	640	Total			

**Subcatchment NE2: NE-SB-2**

Hydrograph

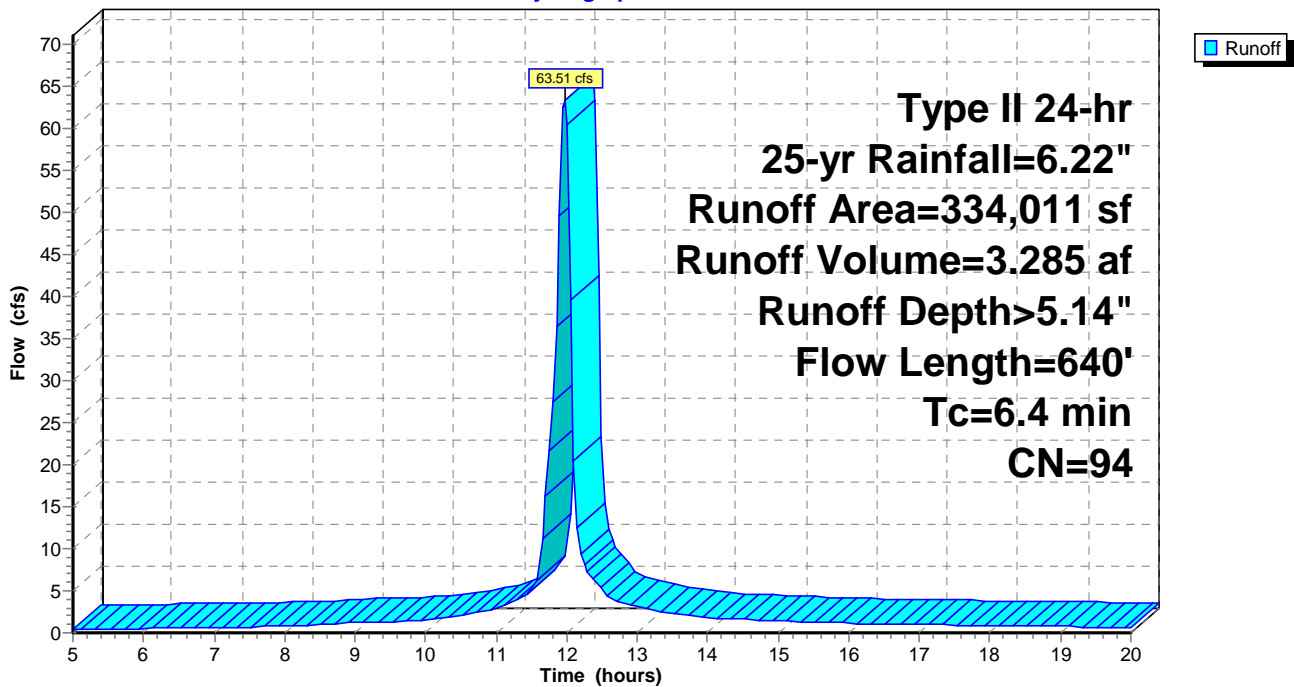

**210730C\_I77\_SEDIMENT\_BASINS**

Prepared by S&ME, Inc.

HydroCAD® 10.00-26 s/n 06707 © 2020 HydroCAD Software Solutions LLC

Type II 24-hr 25-yr Rainfall=6.22"

Printed 3/18/2021

Page 69

**Summary for Subcatchment NE3: NE-SB-3**

No Channel Flow

Runoff = 83.09 cfs @ 11.98 hrs, Volume= 4.339 af, Depth> 5.14"

Runoff by SCS TR-20 method, UH=SCS, Weighted-CN, Time Span= 5.00-20.00 hrs, dt= 0.05 hrs  
Type II 24-hr 25-yr Rainfall=6.22"

Area (sf)	CN	Description
441,198	94	Newly graded area, HSG D
441,198		100.00% Pervious Area

Tc (min)	Length (feet)	Slope (ft/ft)	Velocity (ft/sec)	Capacity (cfs)	Description
4.8	300	0.1075	1.05		<b>Sheet Flow,</b> Fallow n= 0.050 P2= 3.54"
2.3	540	0.1570	3.96		<b>Shallow Concentrated Flow,</b> Nearly Bare & Untilled Kv= 10.0 fps
7.1	840	Total			

**Subcatchment NE3: NE-SB-3**

Hydrograph

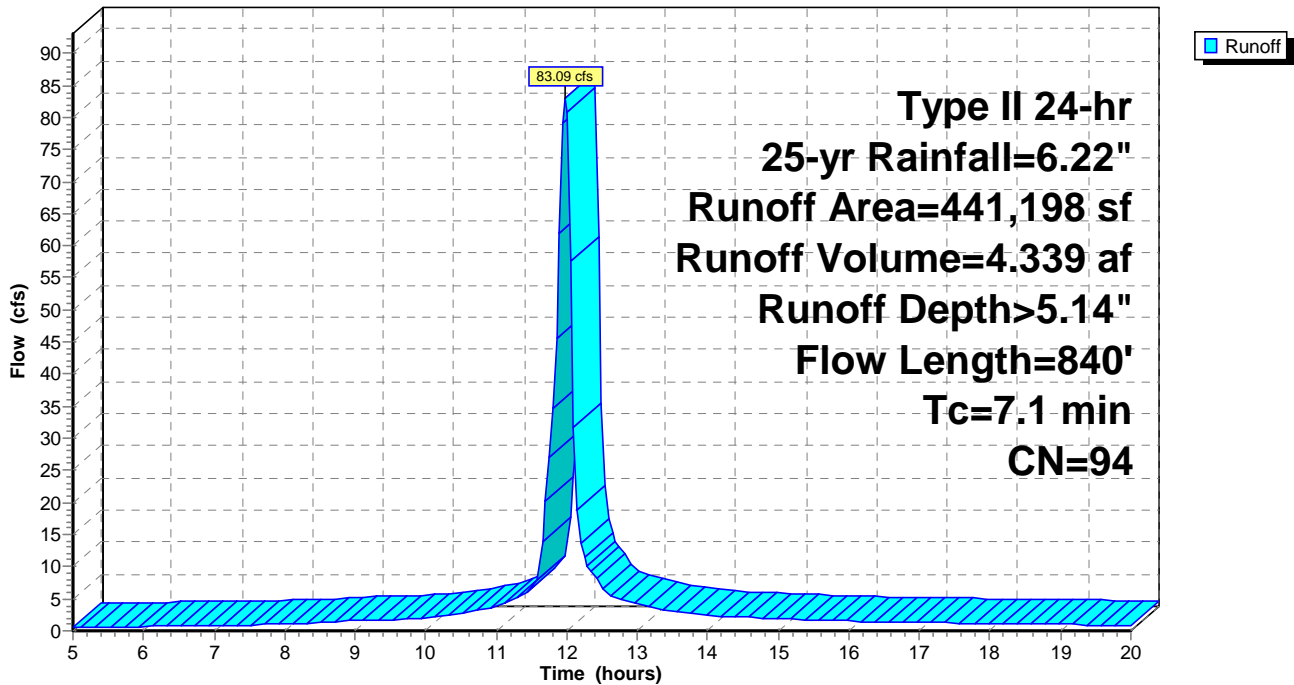

**210730C\_I77\_SEDIMENT\_BASINS**

Prepared by S&ME, Inc.

HydroCAD® 10.00-26 s/n 06707 © 2020 HydroCAD Software Solutions LLC

Type II 24-hr 25-yr Rainfall=6.22"

Printed 3/18/2021

Page 70

**Summary for Subcatchment NE4: NE-SB-4**

No Channel Flow

Runoff = 123.04 cfs @ 11.99 hrs, Volume= 6.679 af, Depth> 5.14"

Runoff by SCS TR-20 method, UH=SCS, Weighted-CN, Time Span= 5.00-20.00 hrs, dt= 0.05 hrs  
Type II 24-hr 25-yr Rainfall=6.22"

Area (sf)	CN	Description
679,173	94	Newly graded area, HSG D
679,173		100.00% Pervious Area

Tc (min)	Length (feet)	Slope (ft/ft)	Velocity (ft/sec)	Capacity (cfs)	Description
5.6	300	0.0719	0.90		<b>Sheet Flow,</b> Fallow n= 0.050 P2= 3.54"
1.8	290	0.0706	2.66		<b>Shallow Concentrated Flow,</b> Nearly Bare & Untilled Kv= 10.0 fps
1.1	1,188	0.0328	17.76	621.77	<b>Channel Flow,</b> Area= 35.0 sf Perim= 20.0' r= 1.75' n= 0.022 Earth, clean & straight
8.5	1,778	Total			

**Subcatchment NE4: NE-SB-4**

Hydrograph

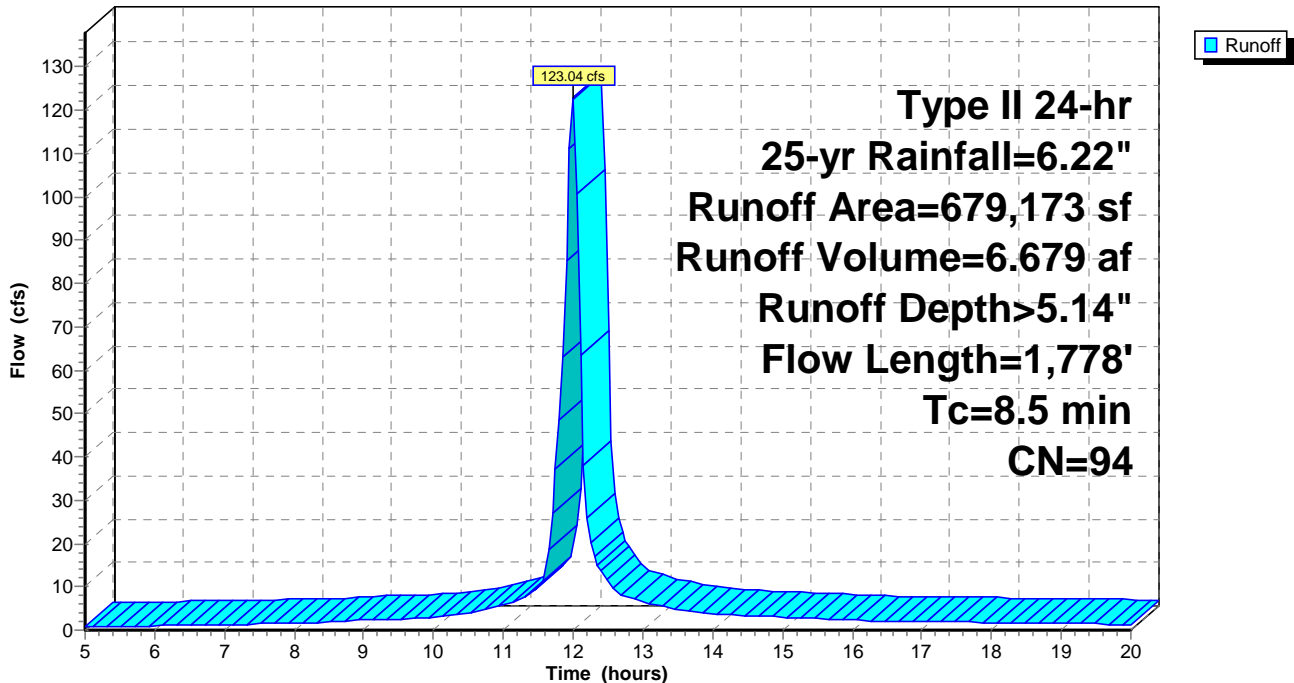

**210730C\_I77\_SEDIMENT\_BASINS**

Prepared by S&ME, Inc.

HydroCAD® 10.00-26 s/n 06707 © 2020 HydroCAD Software Solutions LLC

Type II 24-hr 25-yr Rainfall=6.22"

Printed 3/18/2021

Page 71

**Summary for Subcatchment P1: P-SB-1**

No Channel Flow

Runoff = 295.54 cfs @ 12.05 hrs, Volume= 19.036 af, Depth> 5.14"

Runoff by SCS TR-20 method, UH=SCS, Weighted-CN, Time Span= 5.00-20.00 hrs, dt= 0.05 hrs  
Type II 24-hr 25-yr Rainfall=6.22"

Area (sf)	CN	Description
1,936,988	94	Newly graded area, HSG D
1,936,988		100.00% Pervious Area

Tc (min)	Length (feet)	Slope (ft/ft)	Velocity (ft/sec)	Capacity (cfs)	Description
5.3	300	0.0838	0.95		<b>Sheet Flow,</b> Fallow n= 0.050 P2= 3.54"
7.9	1,294	0.0737	2.71		<b>Shallow Concentrated Flow,</b> Nearly Bare & Untilled Kv= 10.0 fps
0.9	341	0.0045	6.58	230.30	<b>Channel Flow,</b> Area= 35.0 sf Perim= 20.0' r= 1.75' n= 0.022 Earth, clean & straight
14.1	1,935	Total			

**Subcatchment P1: P-SB-1**

Hydrograph

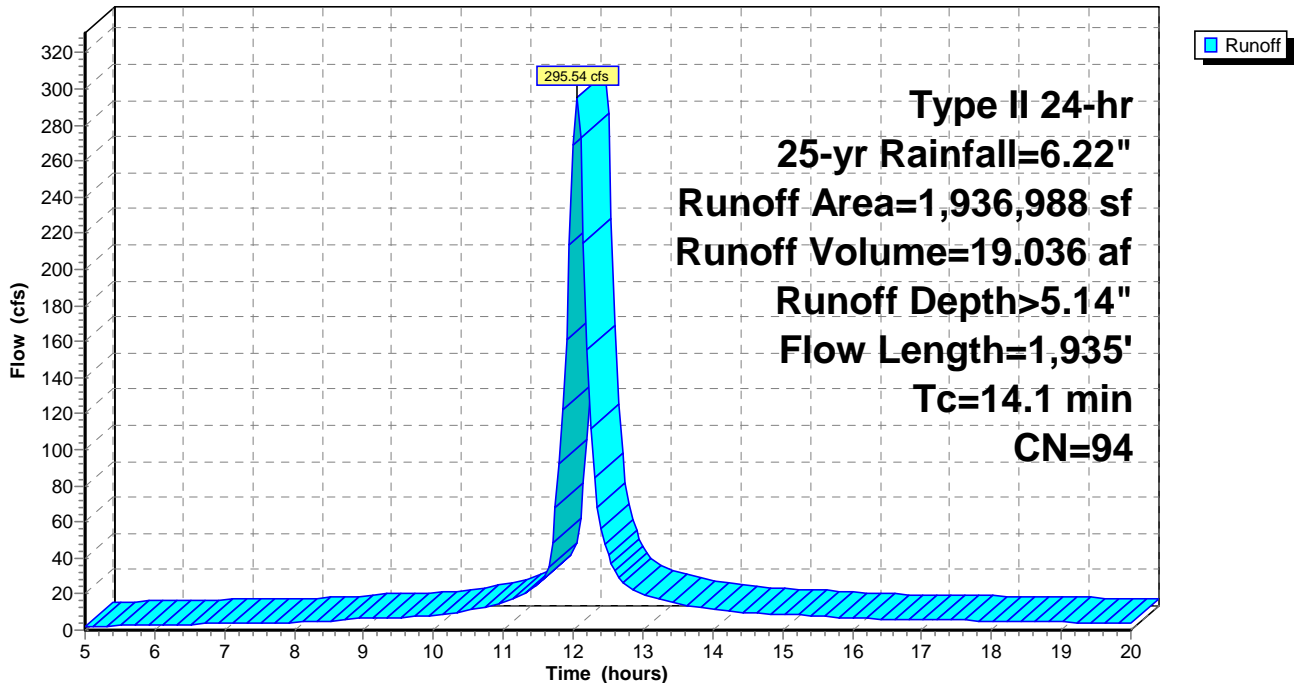



**210730C\_I77\_SEDIMENT\_BASINS**

Prepared by S&ME, Inc.

HydroCAD® 10.00-26 s/n 06707 © 2020 HydroCAD Software Solutions LLC

Type II 24-hr 25-yr Rainfall=6.22"

Printed 3/18/2021

Page 72

**Summary for Subcatchment P2: P-SB-2**

No Channel Flow

Runoff = 109.25 cfs @ 11.99 hrs, Volume= 5.930 af, Depth> 5.14"

Runoff by SCS TR-20 method, UH=SCS, Weighted-CN, Time Span= 5.00-20.00 hrs, dt= 0.05 hrs  
Type II 24-hr 25-yr Rainfall=6.22"

Area (sf)	CN	Description
603,049	94	Newly graded area, HSG D
603,049		100.00% Pervious Area

Tc (min)	Length (feet)	Slope (ft/ft)	Velocity (ft/sec)	Capacity (cfs)	Description
5.2	300	0.0842	0.95		<b>Sheet Flow,</b> Fallow n= 0.050 P2= 3.54"
3.0	582	0.1023	3.20		<b>Shallow Concentrated Flow,</b> Nearly Bare & Untilled Kv= 10.0 fps
0.3	300	0.0240	15.20	531.86	<b>Channel Flow,</b> Area= 35.0 sf Perim= 20.0' r= 1.75' n= 0.022 Earth, clean & straight
8.5	1,182	Total			

**Subcatchment P2: P-SB-2**

Hydrograph

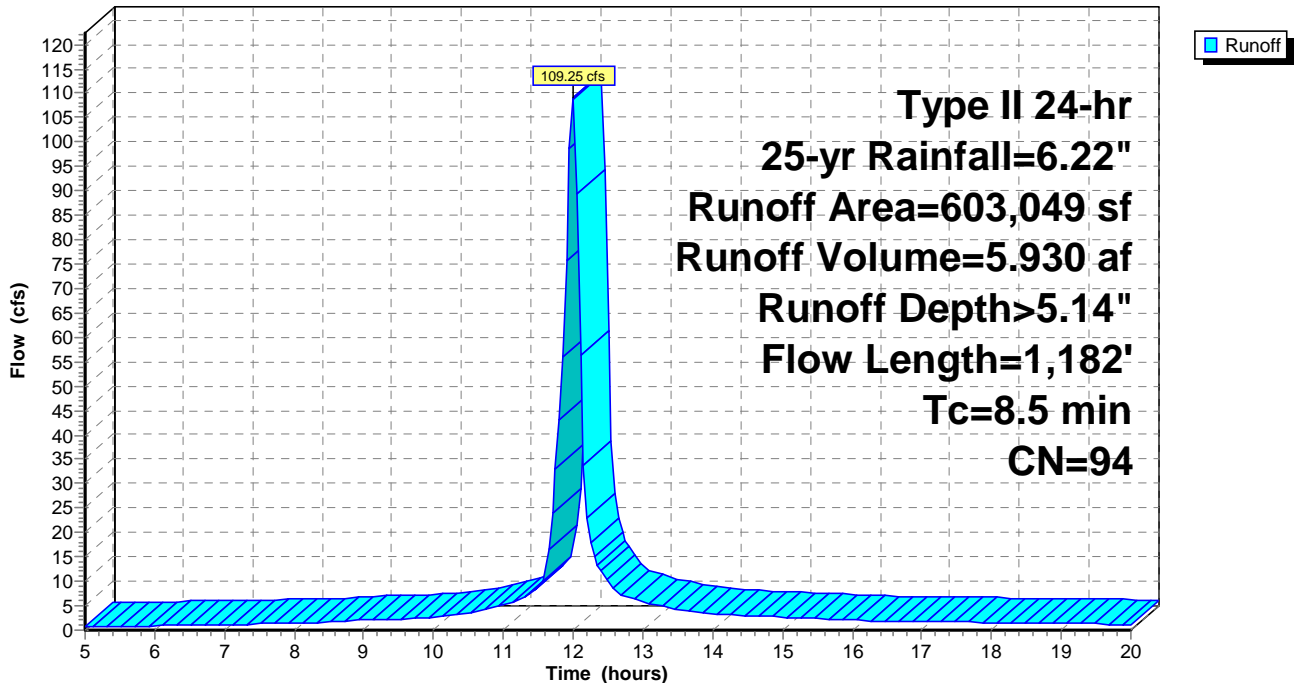

**210730C\_I77\_SEDIMENT\_BASINS**

Prepared by S&ME, Inc.

HydroCAD® 10.00-26 s/n 06707 © 2020 HydroCAD Software Solutions LLC

Type II 24-hr 25-yr Rainfall=6.22"

Printed 3/18/2021

Page 73

**Summary for Subcatchment P3: P-SB-3**

Runoff = 156.69 cfs @ 12.00 hrs, Volume= 8.701 af, Depth> 5.14"

Runoff by SCS TR-20 method, UH=SCS, Weighted-CN, Time Span= 5.00-20.00 hrs, dt= 0.05 hrs  
 Type II 24-hr 25-yr Rainfall=6.22"

Area (sf)	CN	Description
884,859	94	Newly graded area, HSG D
884,859		100.00% Pervious Area

Tc (min)	Length (feet)	Slope (ft/ft)	Velocity (ft/sec)	Capacity (cfs)	Description
4.7	300	0.1095	1.06		<b>Sheet Flow,</b> Fallow n= 0.050 P2= 3.54"
4.3	699	0.0738	2.72		<b>Shallow Concentrated Flow,</b> Nearly Bare & Untilled Kv= 10.0 fps
0.2	113	0.0088	9.20	322.06	<b>Channel Flow,</b> Area= 35.0 sf Perim= 20.0' r= 1.75' n= 0.022 Earth, clean & straight
9.2	1,112	Total			

**Subcatchment P3: P-SB-3**

Hydrograph

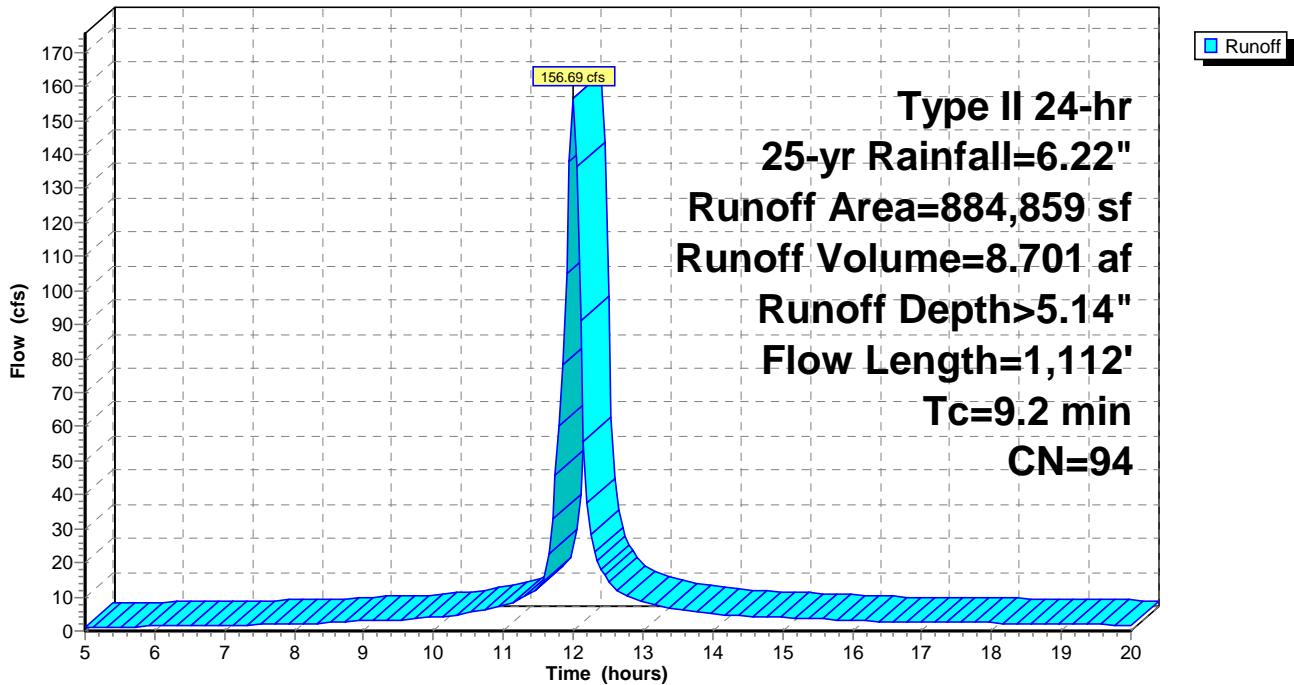

**210730C\_I77\_SEDIMENT\_BASINS**

Prepared by S&ME, Inc.

HydroCAD® 10.00-26 s/n 06707 © 2020 HydroCAD Software Solutions LLC

Type II 24-hr 25-yr Rainfall=6.22"

Printed 3/18/2021

Page 74

**Summary for Subcatchment PT1: PT-SB-1**

No Channel Flow

Runoff = 166.47 cfs @ 12.03 hrs, Volume= 9.952 af, Depth> 5.14"

Runoff by SCS TR-20 method, UH=SCS, Weighted-CN, Time Span= 5.00-20.00 hrs, dt= 0.05 hrs  
Type II 24-hr 25-yr Rainfall=6.22"

Area (sf)	CN	Description
1,012,355	94	Newly graded area, HSG D
1,012,355		100.00% Pervious Area

Tc (min)	Length (feet)	Slope (ft/ft)	Velocity (ft/sec)	Capacity (cfs)	Description
6.2	300	0.0546	0.80		<b>Sheet Flow,</b> Fallow n= 0.050 P2= 3.54"
5.3	804	0.0630	2.51		<b>Shallow Concentrated Flow,</b> Nearly Bare & Untilled Kv= 10.0 fps
11.5	1,104	Total			

**Subcatchment PT1: PT-SB-1**

Hydrograph

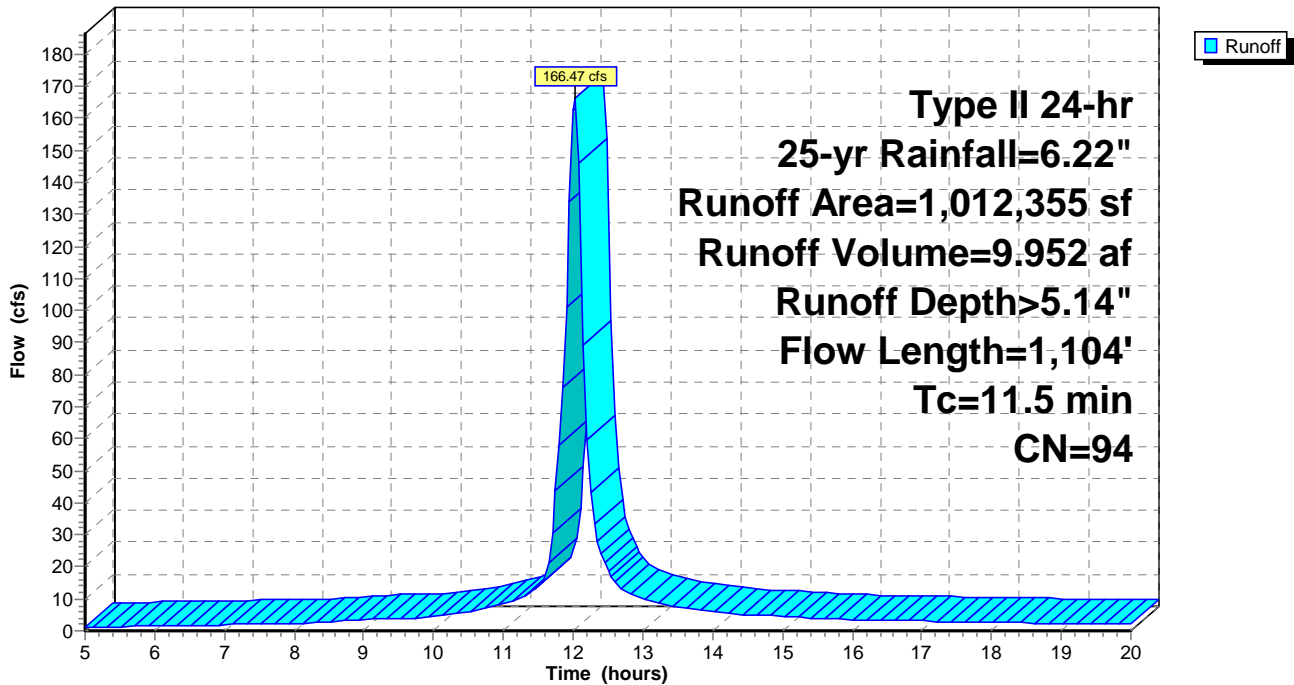

**210730C\_I77\_SEDIMENT\_BASINS**

Type II 24-hr 25-yr Rainfall=6.22"

Prepared by S&ME, Inc.

Printed 3/18/2021

HydroCAD® 10.00-26 s/n 06707 © 2020 HydroCAD Software Solutions LLC

Page 75

**Summary for Subcatchment W1: W-SB-1**

Runoff = 110.63 cfs @ 11.99 hrs, Volume= 5.899 af, Depth> 5.14"

Runoff by SCS TR-20 method, UH=SCS, Weighted-CN, Time Span= 5.00-20.00 hrs, dt= 0.05 hrs  
Type II 24-hr 25-yr Rainfall=6.22"

Area (sf)	CN	Description
599,872	94	Newly graded area, HSG D
599,872		100.00% Pervious Area

Tc (min)	Length (feet)	Slope (ft/ft)	Velocity (ft/sec)	Capacity (cfs)	Description
5.6	300	0.0707	0.89		<b>Sheet Flow,</b> Fallow n= 0.050 P2= 3.54"
1.6	334	0.1196	3.46		<b>Shallow Concentrated Flow,</b> Nearly Bare & Untilled Kv= 10.0 fps
0.7	559	0.0190	13.52	473.22	<b>Channel Flow,</b> Area= 35.0 sf Perim= 20.0' r= 1.75' n= 0.022 Earth, clean & straight
7.9	1,193	Total			

**Subcatchment W1: W-SB-1**

Hydrograph

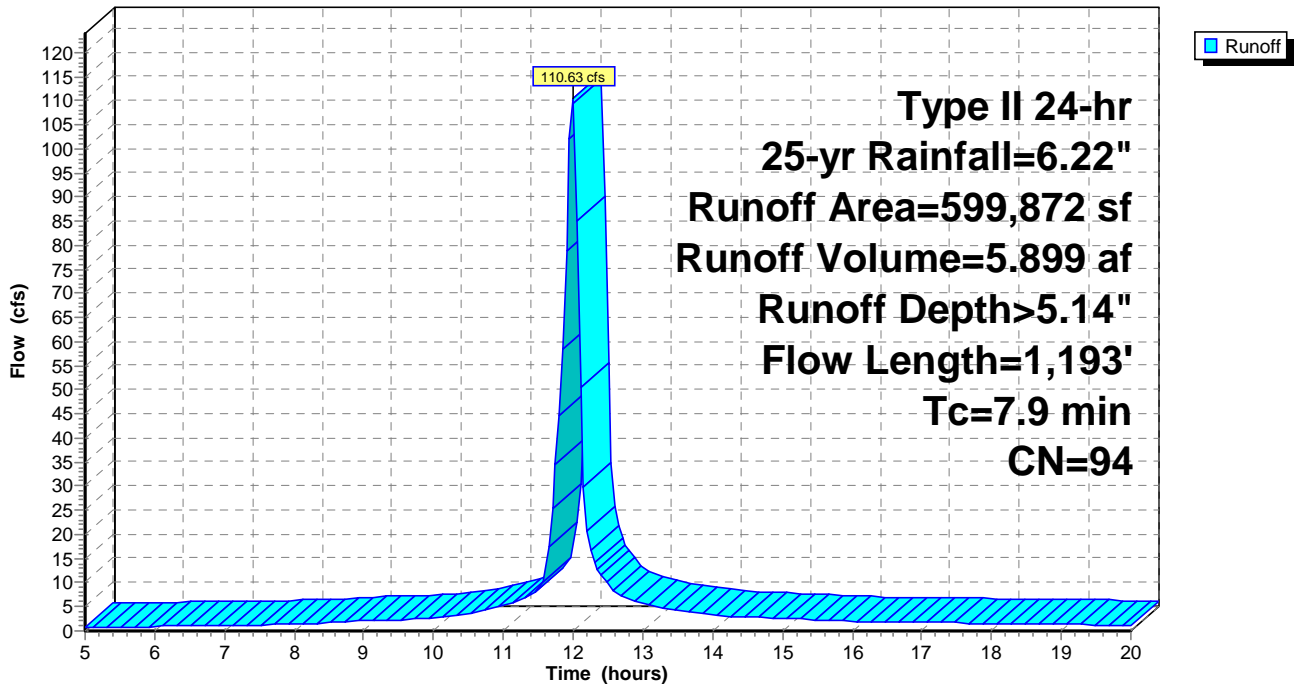

**Summary for Pond 1P: P-PT-SB-1**

[82] Warning: Early inflow requires earlier time span

Inflow Area = 23.240 ac, 0.00% Impervious, Inflow Depth > 5.14" for 25-yr event  
 Inflow = 166.47 cfs @ 12.03 hrs, Volume= 9.952 af  
 Outflow = 6.41 cfs @ 13.80 hrs, Volume= 2.906 af, Atten= 96%, Lag= 106.8 min  
 Primary = 6.41 cfs @ 13.80 hrs, Volume= 2.906 af  
 Secondary = 0.00 cfs @ 5.00 hrs, Volume= 0.000 af

Routing by Stor-Ind method, Time Span= 5.00-20.00 hrs, dt= 0.05 hrs  
 Peak Elev= 562.96' @ 13.80 hrs Surf.Area= 63,853 sf Storage= 317,790 cf

Plug-Flow detention time= 276.1 min calculated for 2.894 af (29% of inflow)  
 Center-of-Mass det. time= 146.5 min ( 889.3 - 742.8 )

Volume	Invert	Avail.Storage	Storage Description
#1	557.00'	455,428 cf	<b>Custom Stage Data (Prismatic)</b> Listed below (Recalc)

Elevation (feet)	Surf.Area (sq-ft)	Inc.Store (cubic-feet)	Cum.Store (cubic-feet)
557.00	42,794	0	0
565.00	71,063	455,428	455,428

Device	Routing	Invert	Outlet Devices
#1	Device 2	557.00'	<b>1.168 cfs Constant Flow/Skimmer</b>
#2	Primary	557.00'	<b>24.0" Round Culvert</b> L= 100.0' CMP, square edge headwall, Ke= 0.500 Inlet / Outlet Invert= 557.00' / 556.00' S= 0.0100 '/' Cc= 0.900 n= 0.012 Concrete pipe, finished, Flow Area= 3.14 sf
#3	Device 2	562.70'	<b>36.0" x 36.0" Horiz. Orifice/Grate</b> C= 0.600 Limited to weir flow at low heads
#4	Secondary	563.70'	<b>20.0' long x 12.0' breadth Broad-Crested Rectangular Weir</b> Head (feet) 0.20 0.40 0.60 0.80 1.00 1.20 1.40 1.60 Coef. (English) 2.57 2.62 2.70 2.67 2.66 2.67 2.66 2.64

**Primary OutFlow** Max=6.36 cfs @ 13.80 hrs HW=562.96' (Free Discharge)  
 ↑ **2=Culvert** (Passes 6.36 cfs of 33.69 cfs potential flow)  
 ↑ **1=Constant Flow/Skimmer** (Constant Controls 1.17 cfs)  
 ↑ **3=Orifice/Grate** (Weir Controls 5.19 cfs @ 1.67 fps)

**Secondary OutFlow** Max=0.00 cfs @ 5.00 hrs HW=557.00' (Free Discharge)  
 ↑ **4=Broad-Crested Rectangular Weir** ( Controls 0.00 cfs)

Pond 1P: P-PT-SB-1

Hydrograph

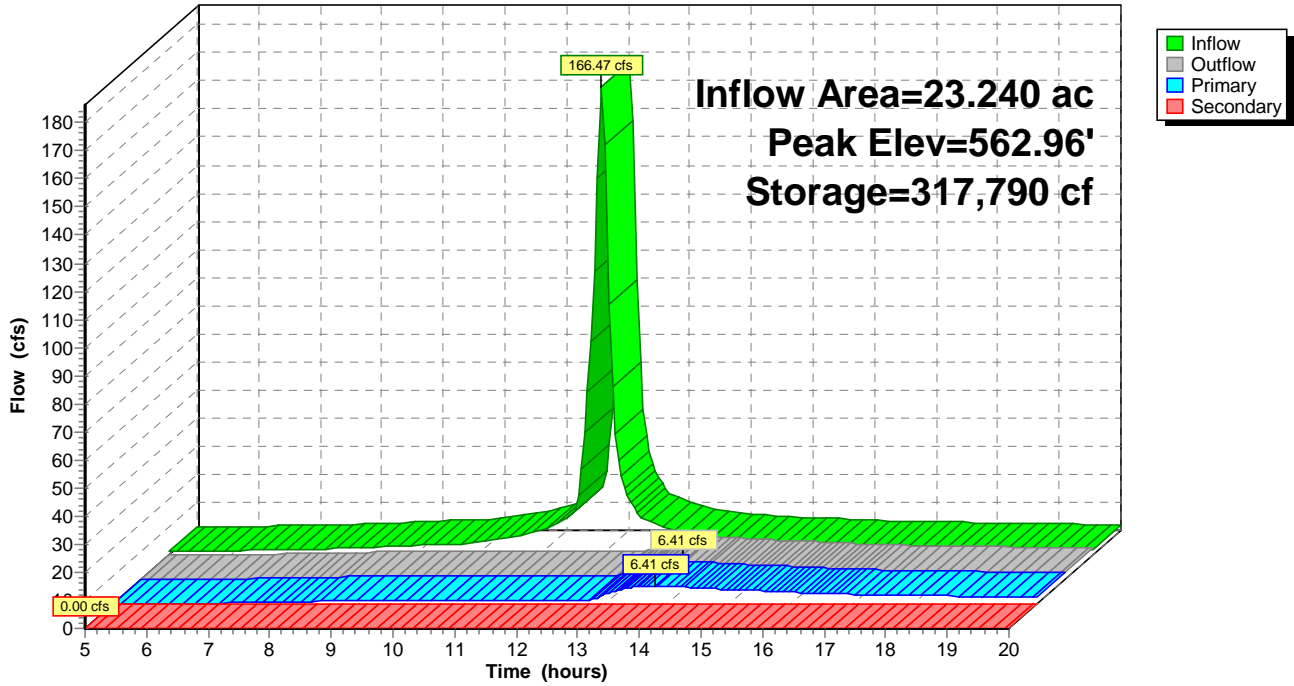

**Summary for Pond 2P: P-W-SB-1**

[82] Warning: Early inflow requires earlier time span

Inflow Area = 13.771 ac, 0.00% Impervious, Inflow Depth > 5.14" for 25-yr event  
 Inflow = 110.63 cfs @ 11.99 hrs, Volume= 5.899 af  
 Outflow = 4.93 cfs @ 13.24 hrs, Volume= 1.978 af, Atten= 96%, Lag= 75.0 min  
 Primary = 4.93 cfs @ 13.24 hrs, Volume= 1.978 af  
 Secondary = 0.00 cfs @ 5.00 hrs, Volume= 0.000 af

Routing by Stor-Ind method, Time Span= 5.00-20.00 hrs, dt= 0.05 hrs  
 Peak Elev= 505.62' @ 13.24 hrs Surf.Area= 38,098 sf Storage= 177,440 cf

Plug-Flow detention time= 237.8 min calculated for 1.977 af (34% of inflow)  
 Center-of-Mass det. time= 120.8 min ( 860.9 - 740.1 )

Volume	Invert	Avail.Storage	Storage Description
#1	500.00'	274,756 cf	<b>Custom Stage Data (Prismatic)</b> Listed below (Recalc)

Elevation (feet)	Surf.Area (sq-ft)	Inc.Store (cubic-feet)	Cum.Store (cubic-feet)
500.00	25,066	0	0
508.00	43,623	274,756	274,756

Device	Routing	Invert	Outlet Devices
#1	Device 2	500.00'	<b>0.894 cfs Constant Flow/Skimmer</b>
#2	Primary	500.00'	<b>24.0" Round Culvert</b> L= 100.0' CMP, square edge headwall, Ke= 0.500 Inlet / Outlet Invert= 500.00' / 499.00' S= 0.0100 '/' Cc= 0.900 n= 0.012 Concrete pipe, finished, Flow Area= 3.14 sf
#3	Device 2	505.40'	<b>36.0" x 36.0" Horiz. Orifice/Grate</b> C= 0.600 Limited to weir flow at low heads
#4	Secondary	506.40'	<b>20.0' long x 12.0' breadth Broad-Crested Rectangular Weir</b> Head (feet) 0.20 0.40 0.60 0.80 1.00 1.20 1.40 1.60 Coef. (English) 2.57 2.62 2.70 2.67 2.66 2.67 2.66 2.64

**Primary OutFlow** Max=4.90 cfs @ 13.24 hrs HW=505.62' (Free Discharge)  
 ↑ **2=Culvert** (Passes 4.90 cfs of 32.51 cfs potential flow)  
 ↑ **1=Constant Flow/Skimmer** (Constant Controls 0.89 cfs)  
 ↑ **3=Orifice/Grate** (Weir Controls 4.00 cfs @ 1.53 fps)

**Secondary OutFlow** Max=0.00 cfs @ 5.00 hrs HW=500.00' (Free Discharge)  
 ↑ **4=Broad-Crested Rectangular Weir** ( Controls 0.00 cfs)

Pond 2P: P-W-SB-1

Hydrograph

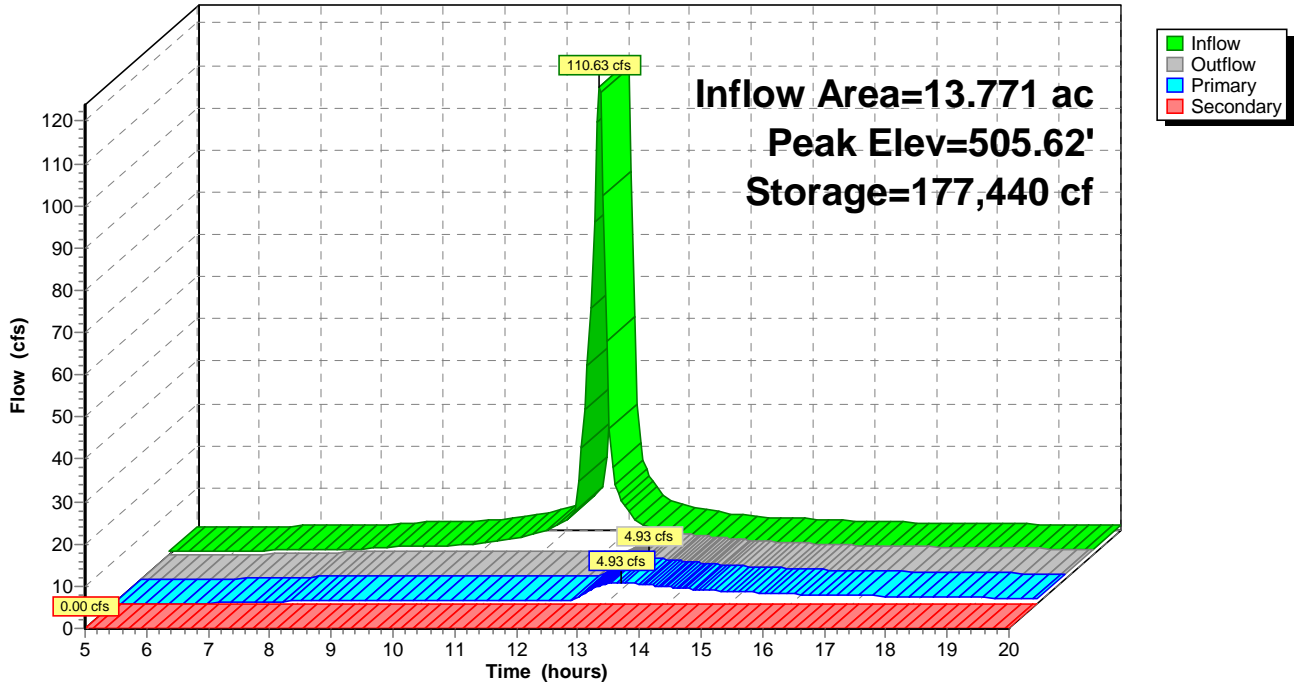



**Summary for Pond 3P: P-P-SB-1**

[82] Warning: Early inflow requires earlier time span

Inflow Area = 44.467 ac, 0.00% Impervious, Inflow Depth > 5.14" for 25-yr event  
 Inflow = 295.54 cfs @ 12.05 hrs, Volume= 19.036 af  
 Outflow = 11.54 cfs @ 13.97 hrs, Volume= 5.542 af, Atten= 96%, Lag= 115.2 min  
 Primary = 11.54 cfs @ 13.97 hrs, Volume= 5.542 af  
 Secondary = 0.00 cfs @ 5.00 hrs, Volume= 0.000 af

Routing by Stor-Ind method, Time Span= 5.00-20.00 hrs, dt= 0.05 hrs  
 Peak Elev= 457.78' @ 13.97 hrs Surf.Area= 95,279 sf Storage= 610,361 cf

Plug-Flow detention time= 278.7 min calculated for 5.520 af (29% of inflow)  
 Center-of-Mass det. time= 148.5 min ( 893.3 - 744.8 )

Volume	Invert	Avail.Storage	Storage Description
#1	450.00'	832,615 cf	<b>Custom Stage Data (Prismatic)</b> Listed below (Recalc)

Elevation (feet)	Surf.Area (sq-ft)	Inc.Store (cubic-feet)	Cum.Store (cubic-feet)
450.00	61,641	0	0
460.00	104,882	832,615	832,615

Device	Routing	Invert	Outlet Devices
#1	Device 2	450.00'	<b>1.168 cfs Constant Flow/Skimmer X 2.00</b>
#2	Primary	450.00'	<b>24.0" Round Culvert</b> L= 100.0' CMP, square edge headwall, Ke= 0.500 Inlet / Outlet Invert= 450.00' / 449.00' S= 0.0100 '/' Cc= 0.900 n= 0.012 Concrete pipe, finished, Flow Area= 3.14 sf
#3	Device 2	457.40'	<b>36.0" x 36.0" Horiz. Orifice/Grate</b> C= 0.600 Limited to weir flow at low heads
#4	Secondary	458.40'	<b>20.0' long x 12.0' breadth Broad-Crested Rectangular Weir</b> Head (feet) 0.20 0.40 0.60 0.80 1.00 1.20 1.40 1.60 Coef. (English) 2.57 2.62 2.70 2.67 2.66 2.67 2.66 2.64

**Primary OutFlow** Max=11.50 cfs @ 13.97 hrs HW=457.78' (Free Discharge)  
 ↑ **2=Culvert** (Passes 11.50 cfs of 39.39 cfs potential flow)  
 ↑ **1=Constant Flow/Skimmer** (Constant Controls 2.34 cfs)  
 ↑ **3=Orifice/Grate** (Weir Controls 9.16 cfs @ 2.01 fps)

**Secondary OutFlow** Max=0.00 cfs @ 5.00 hrs HW=450.00' (Free Discharge)  
 ↑ **4=Broad-Crested Rectangular Weir** ( Controls 0.00 cfs)

Pond 3P: P-P-SB-1

Hydrograph

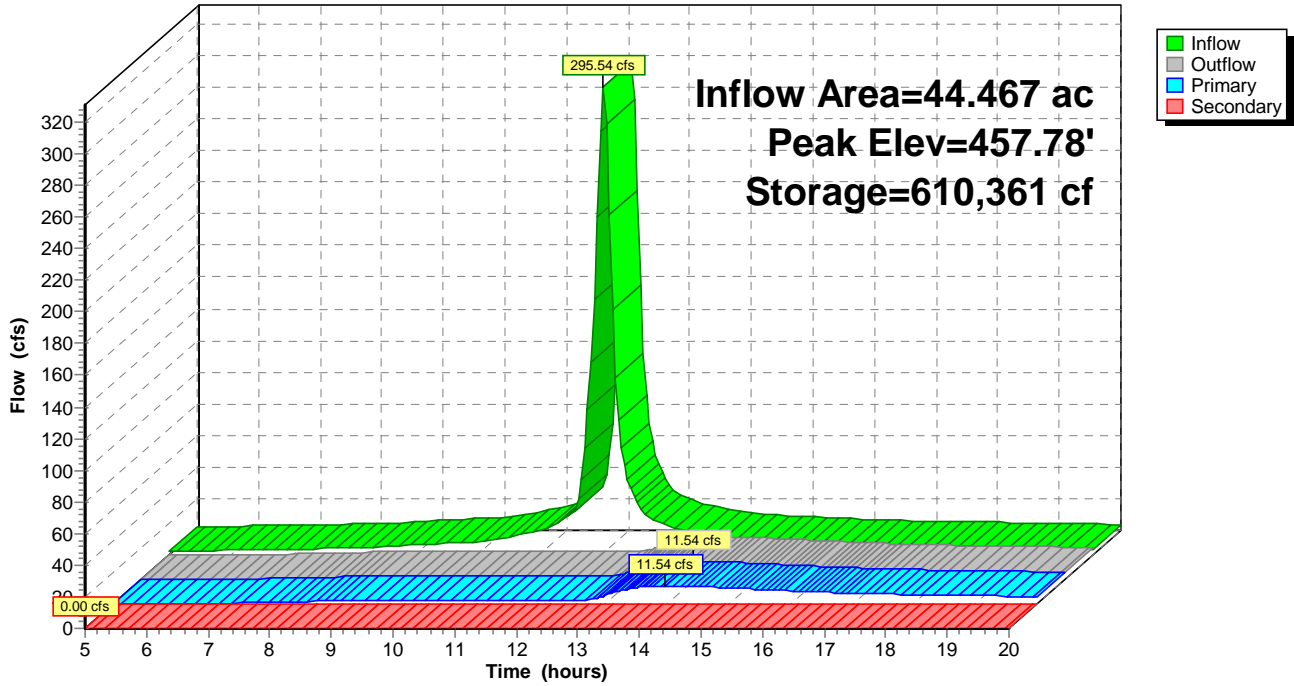

**Summary for Pond 4P: P-P-SB-2**

[82] Warning: Early inflow requires earlier time span

Inflow Area = 13.844 ac, 0.00% Impervious, Inflow Depth > 5.14" for 25-yr event  
 Inflow = 109.25 cfs @ 11.99 hrs, Volume= 5.930 af  
 Outflow = 5.03 cfs @ 13.22 hrs, Volume= 2.006 af, Atten= 95%, Lag= 73.5 min  
 Primary = 5.03 cfs @ 13.22 hrs, Volume= 2.006 af  
 Secondary = 0.00 cfs @ 5.00 hrs, Volume= 0.000 af

Routing by Stor-Ind method, Time Span= 5.00-20.00 hrs, dt= 0.05 hrs  
 Peak Elev= 487.62' @ 13.22 hrs Surf.Area= 34,556 sf Storage= 177,201 cf

Plug-Flow detention time= 230.2 min calculated for 1.998 af (34% of inflow)  
 Center-of-Mass det. time= 114.7 min ( 855.3 - 740.6 )

Volume	Invert	Avail.Storage	Storage Description
#1	481.00'	266,076 cf	<b>Custom Stage Data (Prismatic)</b> Listed below (Recalc)

Elevation (feet)	Surf.Area (sq-ft)	Inc.Store (cubic-feet)	Cum.Store (cubic-feet)
481.00	18,972	0	0
490.00	40,156	266,076	266,076

Device	Routing	Invert	Outlet Devices
#1	Device 2	481.00'	<b>0.894 cfs Constant Flow/Skimmer</b>
#2	Primary	481.00'	<b>24.0" Round Culvert</b> L= 100.0' CMP, square edge headwall, Ke= 0.500 Inlet / Outlet Invert= 481.00' / 480.00' S= 0.0100 '/' Cc= 0.900 n= 0.012 Concrete pipe, finished, Flow Area= 3.14 sf
#3	Device 2	487.40'	<b>36.0" x 36.0" Horiz. Orifice/Grate</b> C= 0.600 Limited to weir flow at low heads
#4	Secondary	488.40'	<b>20.0' long x 12.0' breadth Broad-Crested Rectangular Weir</b> Head (feet) 0.20 0.40 0.60 0.80 1.00 1.20 1.40 1.60 Coef. (English) 2.57 2.62 2.70 2.67 2.66 2.67 2.66 2.64

**Primary OutFlow** Max=4.97 cfs @ 13.22 hrs HW=487.62' (Free Discharge)  
 ↑ **2=Culvert** (Passes 4.97 cfs of 35.86 cfs potential flow)  
 ↑ **1=Constant Flow/Skimmer** (Constant Controls 0.89 cfs)  
 ↑ **3=Orifice/Grate** (Weir Controls 4.07 cfs @ 1.54 fps)

**Secondary OutFlow** Max=0.00 cfs @ 5.00 hrs HW=481.00' (Free Discharge)  
 ↑ **4=Broad-Crested Rectangular Weir** ( Controls 0.00 cfs)

Pond 4P: P-P-SB-2

Hydrograph

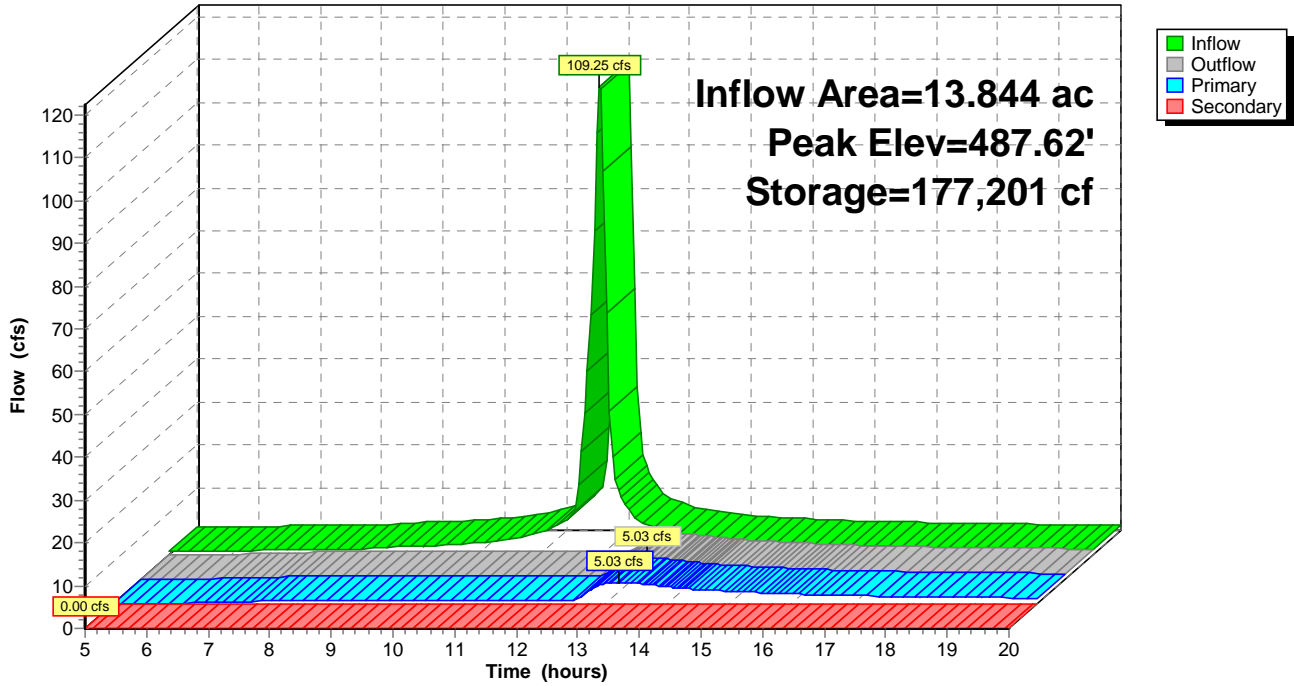

**Summary for Pond 5P: P-P-SB-3**

[82] Warning: Early inflow requires earlier time span

Inflow Area = 20.314 ac, 0.00% Impervious, Inflow Depth > 5.14" for 25-yr event  
 Inflow = 156.69 cfs @ 12.00 hrs, Volume= 8.701 af  
 Outflow = 6.76 cfs @ 13.40 hrs, Volume= 2.808 af, Atten= 96%, Lag= 84.2 min  
 Primary = 6.76 cfs @ 13.40 hrs, Volume= 2.808 af  
 Secondary = 0.00 cfs @ 5.00 hrs, Volume= 0.000 af

Routing by Stor-Ind method, Time Span= 5.00-20.00 hrs, dt= 0.05 hrs  
 Peak Elev= 497.57' @ 13.40 hrs Surf.Area= 45,307 sf Storage= 266,002 cf

Plug-Flow detention time= 243.8 min calculated for 2.796 af (32% of inflow)  
 Center-of-Mass det. time= 123.9 min ( 865.0 - 741.1 )

Volume	Invert	Avail.Storage	Storage Description
#1	490.00'	383,995 cf	<b>Custom Stage Data (Prismatic)</b> Listed below (Recalc)

Elevation (feet)	Surf.Area (sq-ft)	Inc.Store (cubic-feet)	Cum.Store (cubic-feet)
490.00	24,964	0	0
500.00	51,835	383,995	383,995

Device	Routing	Invert	Outlet Devices
#1	Device 2	490.00'	<b>1.168 cfs Constant Flow/Skimmer</b>
#2	Primary	490.00'	<b>24.0" Round Culvert</b> L= 100.0' CMP, square edge headwall, Ke= 0.500 Inlet / Outlet Invert= 490.00' / 489.00' S= 0.0100 '/' Cc= 0.900 n= 0.012 Concrete pipe, finished, Flow Area= 3.14 sf
#3	Device 2	497.30'	<b>36.0" x 36.0" Horiz. Orifice/Grate</b> C= 0.600 Limited to weir flow at low heads
#4	Secondary	498.30'	<b>20.0' long x 12.0' breadth Broad-Crested Rectangular Weir</b> Head (feet) 0.20 0.40 0.60 0.80 1.00 1.20 1.40 1.60 Coef. (English) 2.57 2.62 2.70 2.67 2.66 2.67 2.66 2.64

**Primary OutFlow** Max=6.70 cfs @ 13.40 hrs HW=497.57' (Free Discharge)  
 ↑ **2=Culvert** (Passes 6.70 cfs of 38.77 cfs potential flow)  
 ↑ **1=Constant Flow/Skimmer** (Constant Controls 1.17 cfs)  
 ↑ **3=Orifice/Grate** (Weir Controls 5.53 cfs @ 1.70 fps)

**Secondary OutFlow** Max=0.00 cfs @ 5.00 hrs HW=490.00' (Free Discharge)  
 ↑ **4=Broad-Crested Rectangular Weir** ( Controls 0.00 cfs)

Pond 5P: P-P-SB-3

Hydrograph

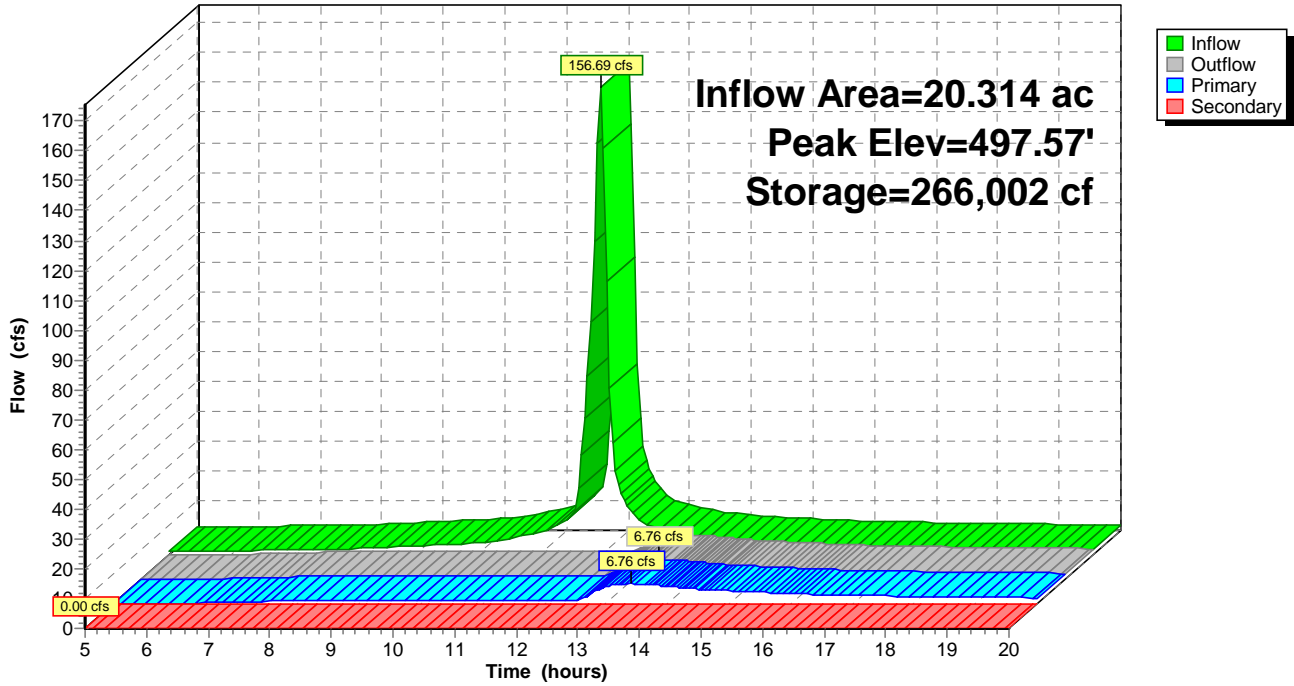

**Summary for Pond 6P: P-NE-SB-1**

[82] Warning: Early inflow requires earlier time span

Inflow Area = 20.801 ac, 0.00% Impervious, Inflow Depth > 5.14" for 25-yr event  
 Inflow = 156.73 cfs @ 12.01 hrs, Volume= 8.909 af  
 Outflow = 6.55 cfs @ 13.51 hrs, Volume= 2.806 af, Atten= 96%, Lag= 90.4 min  
 Primary = 6.55 cfs @ 13.51 hrs, Volume= 2.806 af  
 Secondary = 0.00 cfs @ 5.00 hrs, Volume= 0.000 af

Routing by Stor-Ind method, Time Span= 5.00-20.00 hrs, dt= 0.05 hrs  
 Peak Elev= 434.66' @ 13.51 hrs Surf.Area= 47,330 sf Storage= 275,000 cf

Plug-Flow detention time= 248.1 min calculated for 2.795 af (31% of inflow)  
 Center-of-Mass det. time= 126.0 min ( 867.6 - 741.6 )

Volume	Invert	Avail.Storage	Storage Description
#1	427.00'	393,720 cf	<b>Custom Stage Data (Prismatic)</b> Listed below (Recalc)

Elevation (feet)	Surf.Area (sq-ft)	Inc.Store (cubic-feet)	Cum.Store (cubic-feet)
427.00	24,435	0	0
437.00	54,309	393,720	393,720

Device	Routing	Invert	Outlet Devices
#1	Device 2	427.00'	<b>1.168 cfs Constant Flow/Skimmer</b>
#2	Primary	427.00'	<b>24.0" Round Culvert</b> L= 100.0' CMP, square edge headwall, Ke= 0.500 Inlet / Outlet Invert= 427.00' / 426.00' S= 0.0100 '/' Cc= 0.900 n= 0.012 Concrete pipe, finished, Flow Area= 3.14 sf
#3	Device 2	434.40'	<b>36.0" x 36.0" Horiz. Orifice/Grate</b> C= 0.600 Limited to weir flow at low heads
#4	Secondary	435.40'	<b>20.0' long x 12.0' breadth Broad-Crested Rectangular Weir</b> Head (feet) 0.20 0.40 0.60 0.80 1.00 1.20 1.40 1.60 Coef. (English) 2.57 2.62 2.70 2.67 2.66 2.67 2.66 2.64

**Primary OutFlow** Max=6.49 cfs @ 13.51 hrs HW=434.66' (Free Discharge)  
 ↑ **2=Culvert** (Passes 6.49 cfs of 39.05 cfs potential flow)  
 ↑ **1=Constant Flow/Skimmer** (Constant Controls 1.17 cfs)  
 ↑ **3=Orifice/Grate** (Weir Controls 5.32 cfs @ 1.68 fps)

**Secondary OutFlow** Max=0.00 cfs @ 5.00 hrs HW=427.00' (Free Discharge)  
 ↑ **4=Broad-Crested Rectangular Weir** ( Controls 0.00 cfs)

Pond 6P: P-NE-SB-1

Hydrograph

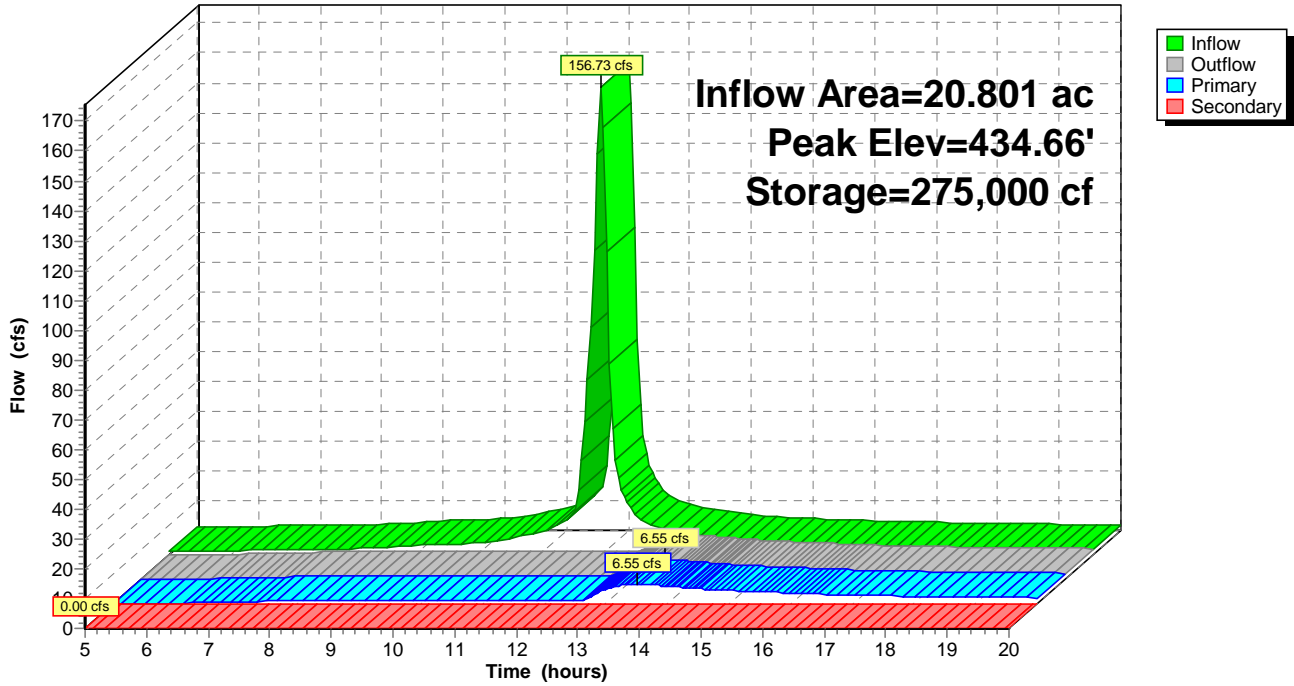



**Summary for Pond 7P: P-NE-SB-2**

[82] Warning: Early inflow requires earlier time span

Inflow Area = 7.668 ac, 0.00% Impervious, Inflow Depth > 5.14" for 25-yr event  
 Inflow = 63.51 cfs @ 11.97 hrs, Volume= 3.285 af  
 Outflow = 3.52 cfs @ 12.85 hrs, Volume= 1.258 af, Atten= 94%, Lag= 52.7 min  
 Primary = 3.52 cfs @ 12.85 hrs, Volume= 1.258 af  
 Secondary = 0.00 cfs @ 5.00 hrs, Volume= 0.000 af

Routing by Stor-Ind method, Time Span= 5.00-20.00 hrs, dt= 0.05 hrs  
 Peak Elev= 416.97' @ 12.85 hrs Surf.Area= 23,554 sf Storage= 92,273 cf

Plug-Flow detention time= 202.4 min calculated for 1.257 af (38% of inflow)  
 Center-of-Mass det. time= 96.7 min ( 835.6 - 739.0 )

Volume	Invert	Avail.Storage	Storage Description
#1	412.00'	172,776 cf	<b>Custom Stage Data (Prismatic)</b> Listed below (Recalc)

Elevation (feet)	Surf.Area (sq-ft)	Inc.Store (cubic-feet)	Cum.Store (cubic-feet)
412.00	13,554	0	0
420.00	29,640	172,776	172,776

Device	Routing	Invert	Outlet Devices
#1	Device 2	412.00'	<b>0.657 cfs Constant Flow/Skimmer</b>
#2	Primary	412.00'	<b>24.0" Round Culvert</b> L= 100.0' CMP, square edge headwall, Ke= 0.500 Inlet / Outlet Invert= 412.00' / 411.00' S= 0.0100 '/' Cc= 0.900 n= 0.012 Concrete pipe, finished, Flow Area= 3.14 sf
#3	Device 2	416.80'	<b>36.0" x 36.0" Horiz. Orifice/Grate</b> C= 0.600 Limited to weir flow at low heads
#4	Secondary	417.80'	<b>20.0' long x 12.0' breadth Broad-Crested Rectangular Weir</b> Head (feet) 0.20 0.40 0.60 0.80 1.00 1.20 1.40 1.60 Coef. (English) 2.57 2.62 2.70 2.67 2.66 2.67 2.66 2.64

**Primary OutFlow** Max=3.49 cfs @ 12.85 hrs HW=416.97' (Free Discharge)  
 ↑ **2=Culvert** (Passes 3.49 cfs of 30.15 cfs potential flow)  
 ↑ **1=Constant Flow/Skimmer** (Constant Controls 0.66 cfs)  
 ↑ **3=Orifice/Grate** (Weir Controls 2.83 cfs @ 1.36 fps)

**Secondary OutFlow** Max=0.00 cfs @ 5.00 hrs HW=412.00' (Free Discharge)  
 ↑ **4=Broad-Crested Rectangular Weir** ( Controls 0.00 cfs)

Pond 7P: P-NE-SB-2

Hydrograph

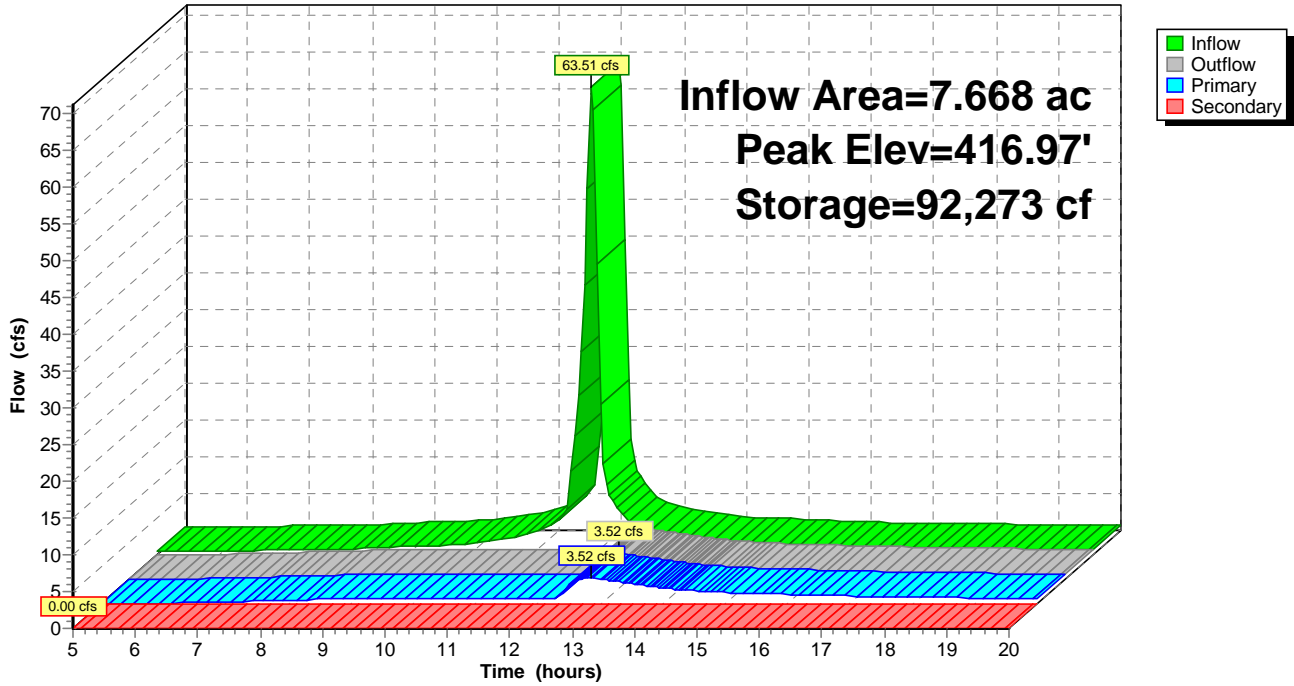

**Summary for Pond 8P: P-NE-SB-3**

[82] Warning: Early inflow requires earlier time span

Inflow Area = 10.129 ac, 0.00% Impervious, Inflow Depth > 5.14" for 25-yr event  
 Inflow = 83.09 cfs @ 11.98 hrs, Volume= 4.339 af  
 Outflow = 3.87 cfs @ 13.11 hrs, Volume= 1.488 af, Atten= 95%, Lag= 67.7 min  
 Primary = 3.87 cfs @ 13.11 hrs, Volume= 1.488 af  
 Secondary = 0.00 cfs @ 5.00 hrs, Volume= 0.000 af

Routing by Stor-Ind method, Time Span= 5.00-20.00 hrs, dt= 0.05 hrs  
 Peak Elev= 418.19' @ 13.11 hrs Surf.Area= 27,540 sf Storage= 128,405 cf

Plug-Flow detention time= 223.4 min calculated for 1.482 af (34% of inflow)  
 Center-of-Mass det. time= 109.3 min ( 848.8 - 739.5 )

Volume	Invert	Avail.Storage	Storage Description
#1	412.00'	214,574 cf	<b>Custom Stage Data (Prismatic)</b> Listed below (Recalc)

Elevation (feet)	Surf.Area (sq-ft)	Inc.Store (cubic-feet)	Cum.Store (cubic-feet)
412.00	13,973	0	0
421.00	33,710	214,574	214,574

Device	Routing	Invert	Outlet Devices
#1	Device 2	412.00'	<b>0.657 cfs Constant Flow/Skimmer</b>
#2	Primary	412.00'	<b>24.0" Round Culvert</b> L= 100.0' CMP, square edge headwall, Ke= 0.500 Inlet / Outlet Invert= 412.00' / 411.00' S= 0.0100 '/' Cc= 0.900 n= 0.012 Concrete pipe, finished, Flow Area= 3.14 sf
#3	Device 2	418.00'	<b>36.0" x 36.0" Horiz. Orifice/Grate</b> C= 0.600 Limited to weir flow at low heads
#4	Secondary	419.00'	<b>20.0' long x 12.0' breadth Broad-Crested Rectangular Weir</b> Head (feet) 0.20 0.40 0.60 0.80 1.00 1.20 1.40 1.60 Coef. (English) 2.57 2.62 2.70 2.67 2.66 2.67 2.66 2.64

**Primary OutFlow** Max=3.81 cfs @ 13.11 hrs HW=418.19' (Free Discharge)  
 ↑ **2=Culvert** (Passes 3.81 cfs of 34.45 cfs potential flow)  
 ↑ **1=Constant Flow/Skimmer** (Constant Controls 0.66 cfs)  
 ↑ **3=Orifice/Grate** (Weir Controls 3.15 cfs @ 1.41 fps)

**Secondary OutFlow** Max=0.00 cfs @ 5.00 hrs HW=412.00' (Free Discharge)  
 ↑ **4=Broad-Crested Rectangular Weir** ( Controls 0.00 cfs)

Pond 8P: P-NE-SB-3

Hydrograph

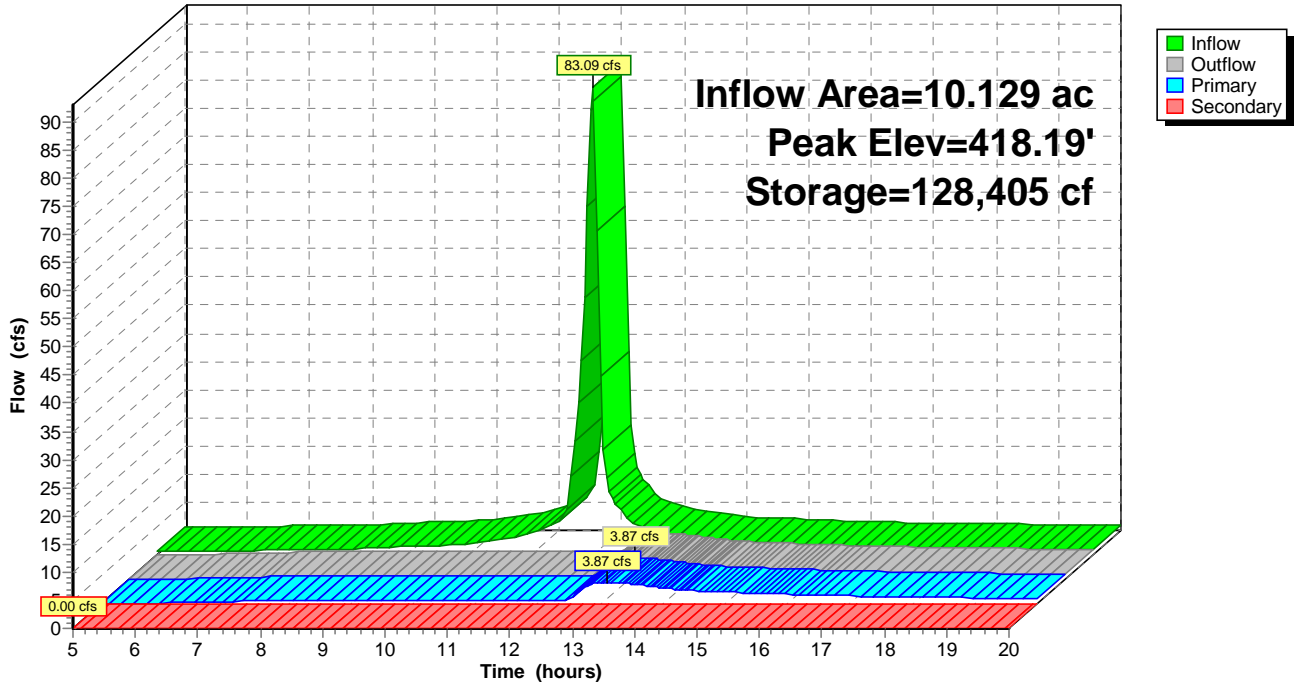

**Summary for Pond 9P: P-NE-SB-4**

[82] Warning: Early inflow requires earlier time span

Inflow Area = 15.592 ac, 0.00% Impervious, Inflow Depth > 5.14" for 25-yr event  
 Inflow = 123.04 cfs @ 11.99 hrs, Volume= 6.679 af  
 Outflow = 5.51 cfs @ 13.27 hrs, Volume= 2.296 af, Atten= 96%, Lag= 76.8 min  
 Primary = 5.51 cfs @ 13.27 hrs, Volume= 2.296 af  
 Secondary = 0.00 cfs @ 5.00 hrs, Volume= 0.000 af

Routing by Stor-Ind method, Time Span= 5.00-20.00 hrs, dt= 0.05 hrs  
 Peak Elev= 484.73' @ 13.27 hrs Surf.Area= 42,114 sf Storage= 199,073 cf

Plug-Flow detention time= 232.0 min calculated for 2.286 af (34% of inflow)  
 Center-of-Mass det. time= 117.9 min ( 858.4 - 740.6 )

Volume	Invert	Avail.Storage	Storage Description
#1	479.00'	301,356 cf	<b>Custom Stage Data (Prismatic)</b> Listed below (Recalc)

Elevation (feet)	Surf.Area (sq-ft)	Inc.Store (cubic-feet)	Cum.Store (cubic-feet)
479.00	27,386	0	0
487.00	47,953	301,356	301,356

Device	Routing	Invert	Outlet Devices
#1	Device 2	479.00'	<b>1.168 cfs Constant Flow/Skimmer</b>
#2	Primary	479.00'	<b>24.0" Round Culvert</b> L= 100.0' CMP, square edge headwall, Ke= 0.500 Inlet / Outlet Invert= 479.00' / 478.00' S= 0.0100 '/' Cc= 0.900 n= 0.012 Concrete pipe, finished, Flow Area= 3.14 sf
#3	Device 2	484.50'	<b>36.0" x 36.0" Horiz. Orifice/Grate</b> C= 0.600 Limited to weir flow at low heads
#4	Secondary	485.50'	<b>20.0' long x 12.0' breadth Broad-Crested Rectangular Weir</b> Head (feet) 0.20 0.40 0.60 0.80 1.00 1.20 1.40 1.60 Coef. (English) 2.57 2.62 2.70 2.67 2.66 2.67 2.66 2.64

**Primary OutFlow** Max=5.46 cfs @ 13.27 hrs HW=484.73' (Free Discharge)  
 ↑ **2=Culvert** (Passes 5.46 cfs of 32.89 cfs potential flow)  
 ↑ **1=Constant Flow/Skimmer** (Constant Controls 1.17 cfs)  
 ↑ **3=Orifice/Grate** (Weir Controls 4.29 cfs @ 1.56 fps)

**Secondary OutFlow** Max=0.00 cfs @ 5.00 hrs HW=479.00' (Free Discharge)  
 ↑ **4=Broad-Crested Rectangular Weir** ( Controls 0.00 cfs)

Pond 9P: P-NE-SB-4

Hydrograph

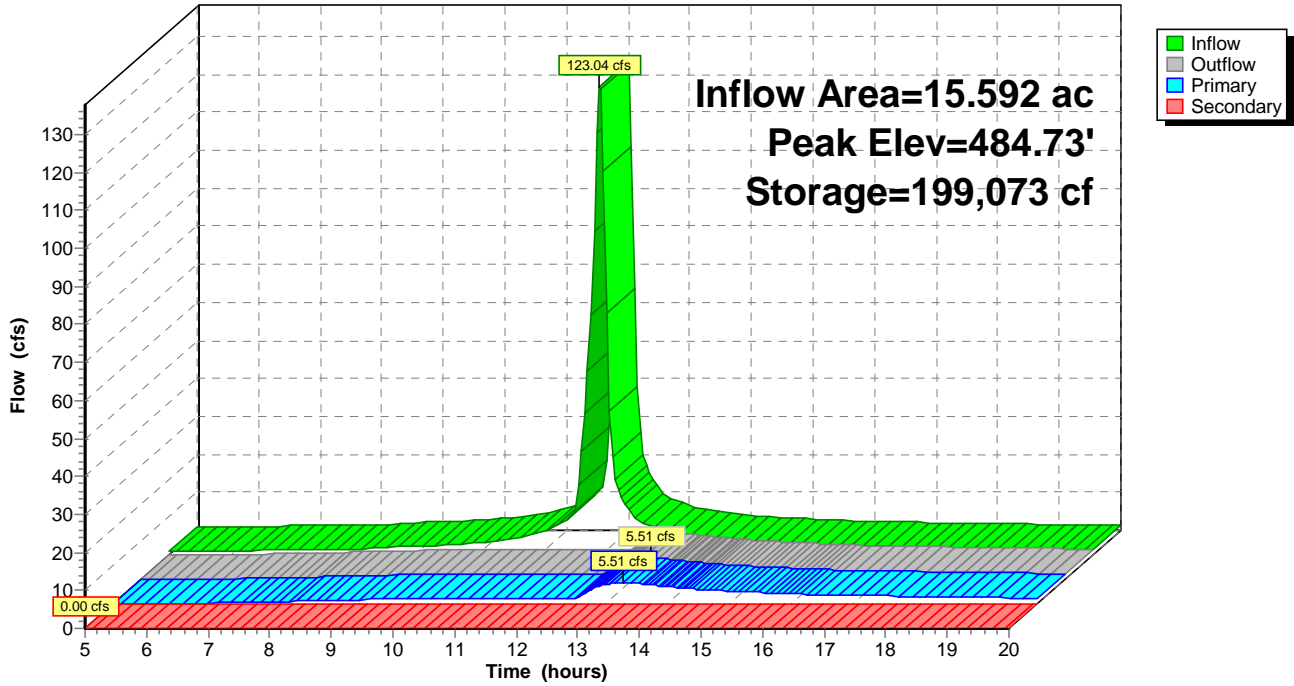

**210730C\_I77\_SEDIMENT\_BASINS**

Type II 24-hr 100-yr Rainfall=8.09"

Prepared by S&amp;ME, Inc.

Printed 3/18/2021

HydroCAD® 10.00-26 s/n 06707 © 2020 HydroCAD Software Solutions LLC

Page 94

Time span=5.00-20.00 hrs, dt=0.05 hrs, 301 points  
 Runoff by SCS TR-20 method, UH=SCS, Weighted-CN  
 Reach routing by Stor-Ind+Trans method - Pond routing by Stor-Ind method

<b>Subcatchment NE1: NE-SB-1</b>	Runoff Area=906,076 sf 0.00% Impervious Runoff Depth>6.84" Flow Length=990' Tc=9.9 min CN=94 Runoff=206.20 cfs 11.860 af
<b>Subcatchment NE2: NE-SB-2</b>	Runoff Area=334,011 sf 0.00% Impervious Runoff Depth>6.84" Flow Length=640' Tc=6.4 min CN=94 Runoff=83.52 cfs 4.373 af
<b>Subcatchment NE3: NE-SB-3</b>	Runoff Area=441,198 sf 0.00% Impervious Runoff Depth>6.84" Flow Length=840' Tc=7.1 min CN=94 Runoff=109.26 cfs 5.776 af
<b>Subcatchment NE4: NE-SB-4</b>	Runoff Area=679,173 sf 0.00% Impervious Runoff Depth>6.84" Flow Length=1,778' Tc=8.5 min CN=94 Runoff=161.83 cfs 8.891 af
<b>Subcatchment P1: P-SB-1</b>	Runoff Area=1,936,988 sf 0.00% Impervious Runoff Depth>6.84" Flow Length=1,935' Tc=14.1 min CN=94 Runoff=389.04 cfs 25.346 af
<b>Subcatchment P2: P-SB-2</b>	Runoff Area=603,049 sf 0.00% Impervious Runoff Depth>6.84" Flow Length=1,182' Tc=8.5 min CN=94 Runoff=143.69 cfs 7.895 af
<b>Subcatchment P3: P-SB-3</b>	Runoff Area=884,859 sf 0.00% Impervious Runoff Depth>6.84" Flow Length=1,112' Tc=9.2 min CN=94 Runoff=206.12 cfs 11.583 af
<b>Subcatchment PT1: PT-SB-1</b>	Runoff Area=1,012,355 sf 0.00% Impervious Runoff Depth>6.84" Flow Length=1,104' Tc=11.5 min CN=94 Runoff=218.38 cfs 13.250 af
<b>Subcatchment W1: W-SB-1</b>	Runoff Area=599,872 sf 0.00% Impervious Runoff Depth>6.84" Flow Length=1,193' Tc=7.9 min CN=94 Runoff=145.49 cfs 7.853 af
<b>Pond 1P: P-PT-SB-1</b>	Peak Elev=563.58' Storage=358,130 cf Inflow=218.38 cfs 13.250 af Primary=33.36 cfs 6.153 af Secondary=0.00 cfs 0.000 af Outflow=33.36 cfs 6.153 af
<b>Pond 2P: P-W-SB-1</b>	Peak Elev=506.21' Storage=200,363 cf Inflow=145.49 cfs 7.853 af Primary=29.49 cfs 3.911 af Secondary=0.00 cfs 0.000 af Outflow=29.49 cfs 3.911 af
<b>Pond 3P: P-P-SB-1</b>	Peak Elev=458.69' Storage=698,442 cf Inflow=389.04 cfs 25.346 af Primary=41.93 cfs 11.435 af Secondary=7.94 cfs 0.302 af Outflow=49.88 cfs 11.737 af
<b>Pond 4P: P-P-SB-2</b>	Peak Elev=488.25' Storage=199,432 cf Inflow=143.69 cfs 7.895 af Primary=31.71 cfs 3.946 af Secondary=0.00 cfs 0.000 af Outflow=31.71 cfs 3.946 af
<b>Pond 5P: P-P-SB-3</b>	Peak Elev=498.29' Storage=299,411 cf Inflow=206.12 cfs 11.583 af Primary=39.99 cfs 5.653 af Secondary=0.00 cfs 0.000 af Outflow=39.99 cfs 5.653 af
<b>Pond 6P: P-NE-SB-1</b>	Peak Elev=435.36' Storage=308,915 cf Inflow=206.20 cfs 11.860 af Primary=38.40 cfs 5.721 af Secondary=0.00 cfs 0.000 af Outflow=38.40 cfs 5.721 af
<b>Pond 7P: P-NE-SB-2</b>	Peak Elev=417.51' Storage=105,234 cf Inflow=83.52 cfs 4.373 af Primary=24.17 cfs 2.336 af Secondary=0.00 cfs 0.000 af Outflow=24.17 cfs 2.336 af

**210730C\_I77\_SEDIMENT\_BASINS**

Type II 24-hr 100-yr Rainfall=8.09"

Prepared by S&ME, Inc.

Printed 3/18/2021

HydroCAD® 10.00-26 s/n 06707 © 2020 HydroCAD Software Solutions LLC

Page 95

**Pond 8P: P-NE-SB-3**

Peak Elev=418.76' Storage=144,425 cf Inflow=109.26 cfs 5.776 af  
Primary=26.41 cfs 2.914 af Secondary=0.00 cfs 0.000 af Outflow=26.41 cfs 2.914 af

**Pond 9P: P-NE-SB-4**

Peak Elev=485.35' Storage=225,574 cf Inflow=161.83 cfs 8.891 af  
Primary=31.74 cfs 4.478 af Secondary=0.00 cfs 0.000 af Outflow=31.74 cfs 4.478 af

**Total Runoff Area = 169.825 ac Runoff Volume = 96.829 af Average Runoff Depth = 6.84"**  
**100.00% Pervious = 169.825 ac 0.00% Impervious = 0.000 ac**



**210730C\_I77\_SEDIMENT\_BASINS**

Prepared by S&ME, Inc.

HydroCAD® 10.00-26 s/n 06707 © 2020 HydroCAD Software Solutions LLC

Type II 24-hr 100-yr Rainfall=8.09"

Printed 3/18/2021

Page 96

**Summary for Subcatchment NE1: NE-SB-1**

Runoff = 206.20 cfs @ 12.01 hrs, Volume= 11.860 af, Depth> 6.84"

Runoff by SCS TR-20 method, UH=SCS, Weighted-CN, Time Span= 5.00-20.00 hrs, dt= 0.05 hrs  
 Type II 24-hr 100-yr Rainfall=8.09"

Area (sf)	CN	Description
906,076	94	Newly graded area, HSG D
906,076		100.00% Pervious Area

Tc (min)	Length (feet)	Slope (ft/ft)	Velocity (ft/sec)	Capacity (cfs)	Description
6.7	300	0.0464	0.75		<b>Sheet Flow,</b> Fallow n= 0.050 P2= 3.54"
3.2	690	0.1262	3.55		<b>Shallow Concentrated Flow,</b> Nearly Bare & Untilled Kv= 10.0 fps
9.9	990	Total			

**Subcatchment NE1: NE-SB-1**

Hydrograph

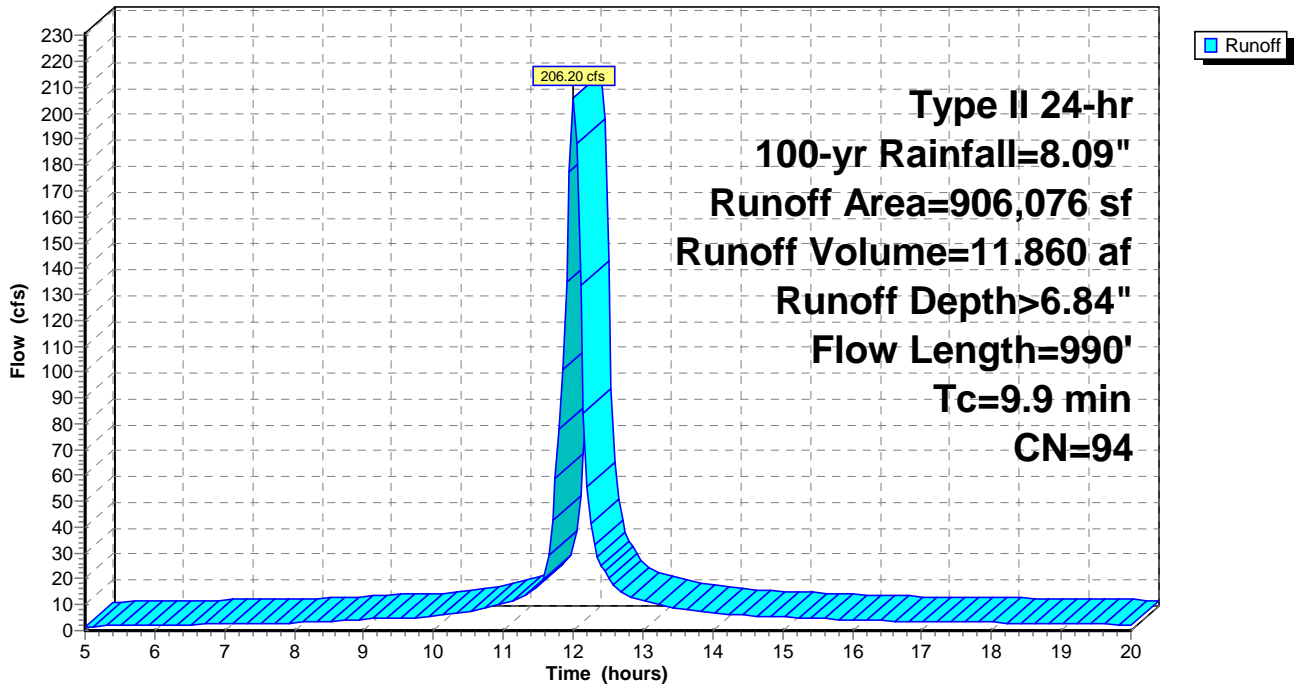

**210730C\_I77\_SEDIMENT\_BASINS**

Prepared by S&ME, Inc.

HydroCAD® 10.00-26 s/n 06707 © 2020 HydroCAD Software Solutions LLC

Type II 24-hr 100-yr Rainfall=8.09"

Printed 3/18/2021

Page 97

**Summary for Subcatchment NE2: NE-SB-2**

No Channel Flow

Runoff = 83.52 cfs @ 11.97 hrs, Volume= 4.373 af, Depth> 6.84"

Runoff by SCS TR-20 method, UH=SCS, Weighted-CN, Time Span= 5.00-20.00 hrs, dt= 0.05 hrs  
Type II 24-hr 100-yr Rainfall=8.09"

Area (sf)	CN	Description
334,011	94	Newly graded area, HSG D
334,011		100.00% Pervious Area

Tc (min)	Length (feet)	Slope (ft/ft)	Velocity (ft/sec)	Capacity (cfs)	Description
5.3	300	0.0812	0.94		<b>Sheet Flow,</b> Fallow n= 0.050 P2= 3.54"
1.1	340	0.2754	5.25		<b>Shallow Concentrated Flow,</b> Nearly Bare & Untilled Kv= 10.0 fps
6.4	640	Total			

**Subcatchment NE2: NE-SB-2**

Hydrograph

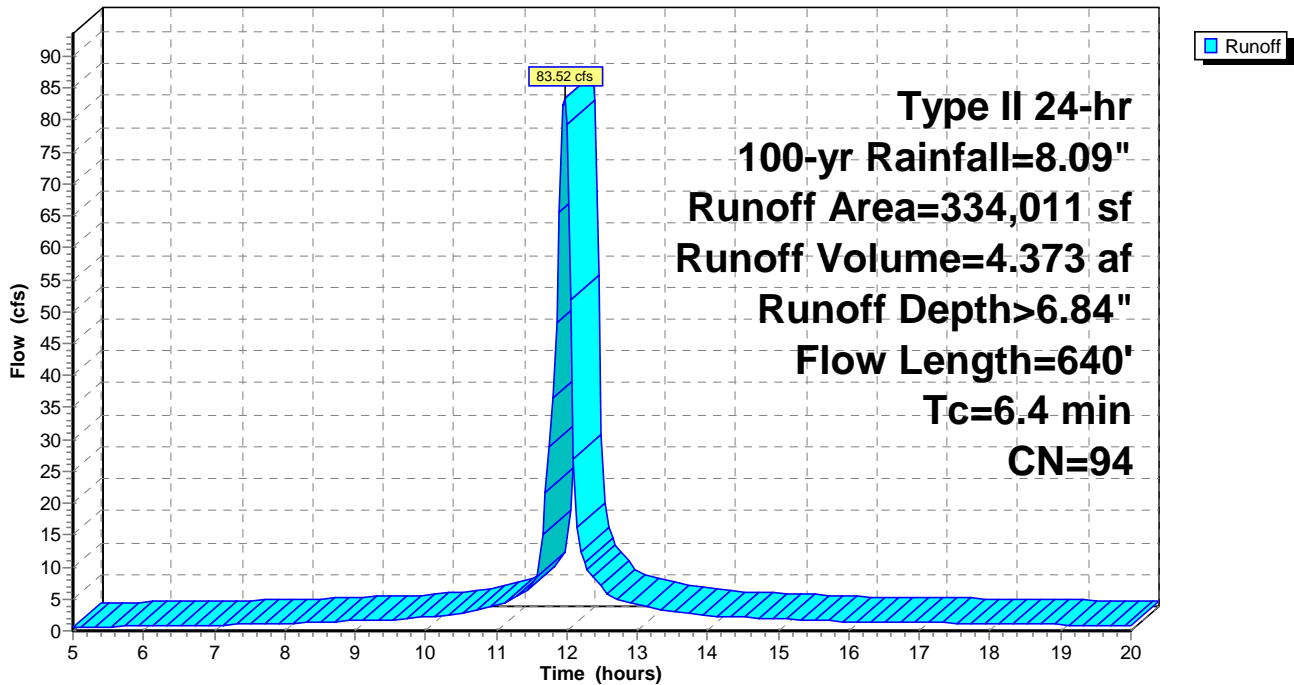

**210730C\_I77\_SEDIMENT\_BASINS**

Prepared by S&ME, Inc.

HydroCAD® 10.00-26 s/n 06707 © 2020 HydroCAD Software Solutions LLC

Type II 24-hr 100-yr Rainfall=8.09"

Printed 3/18/2021

Page 98

**Summary for Subcatchment NE3: NE-SB-3**

No Channel Flow

Runoff = 109.26 cfs @ 11.98 hrs, Volume= 5.776 af, Depth> 6.84"

Runoff by SCS TR-20 method, UH=SCS, Weighted-CN, Time Span= 5.00-20.00 hrs, dt= 0.05 hrs  
Type II 24-hr 100-yr Rainfall=8.09"

Area (sf)	CN	Description
441,198	94	Newly graded area, HSG D
441,198		100.00% Pervious Area

Tc (min)	Length (feet)	Slope (ft/ft)	Velocity (ft/sec)	Capacity (cfs)	Description
4.8	300	0.1075	1.05		<b>Sheet Flow,</b> Fallow n= 0.050 P2= 3.54"
2.3	540	0.1570	3.96		<b>Shallow Concentrated Flow,</b> Nearly Bare & Untilled Kv= 10.0 fps
7.1	840	Total			

**Subcatchment NE3: NE-SB-3**

Hydrograph

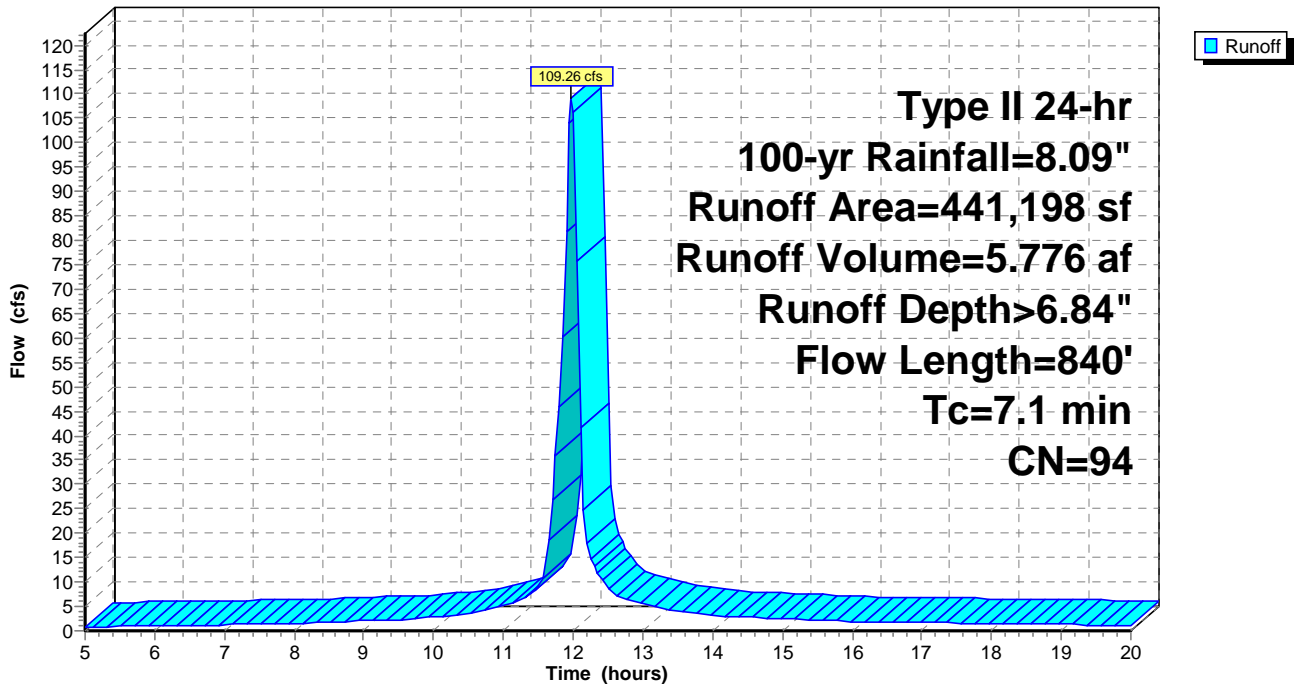

**210730C\_I77\_SEDIMENT\_BASINS**

Prepared by S&ME, Inc.

HydroCAD® 10.00-26 s/n 06707 © 2020 HydroCAD Software Solutions LLC

Type II 24-hr 100-yr Rainfall=8.09"

Printed 3/18/2021

Page 99

**Summary for Subcatchment NE4: NE-SB-4**

No Channel Flow

Runoff = 161.83 cfs @ 11.99 hrs, Volume= 8.891 af, Depth> 6.84"

Runoff by SCS TR-20 method, UH=SCS, Weighted-CN, Time Span= 5.00-20.00 hrs, dt= 0.05 hrs  
Type II 24-hr 100-yr Rainfall=8.09"

Area (sf)	CN	Description
679,173	94	Newly graded area, HSG D
679,173		100.00% Pervious Area

Tc (min)	Length (feet)	Slope (ft/ft)	Velocity (ft/sec)	Capacity (cfs)	Description
5.6	300	0.0719	0.90		<b>Sheet Flow,</b> Fallow n= 0.050 P2= 3.54"
1.8	290	0.0706	2.66		<b>Shallow Concentrated Flow,</b> Nearly Bare & Untilled Kv= 10.0 fps
1.1	1,188	0.0328	17.76	621.77	<b>Channel Flow,</b> Area= 35.0 sf Perim= 20.0' r= 1.75' n= 0.022 Earth, clean & straight
8.5	1,778	Total			

**Subcatchment NE4: NE-SB-4**

Hydrograph

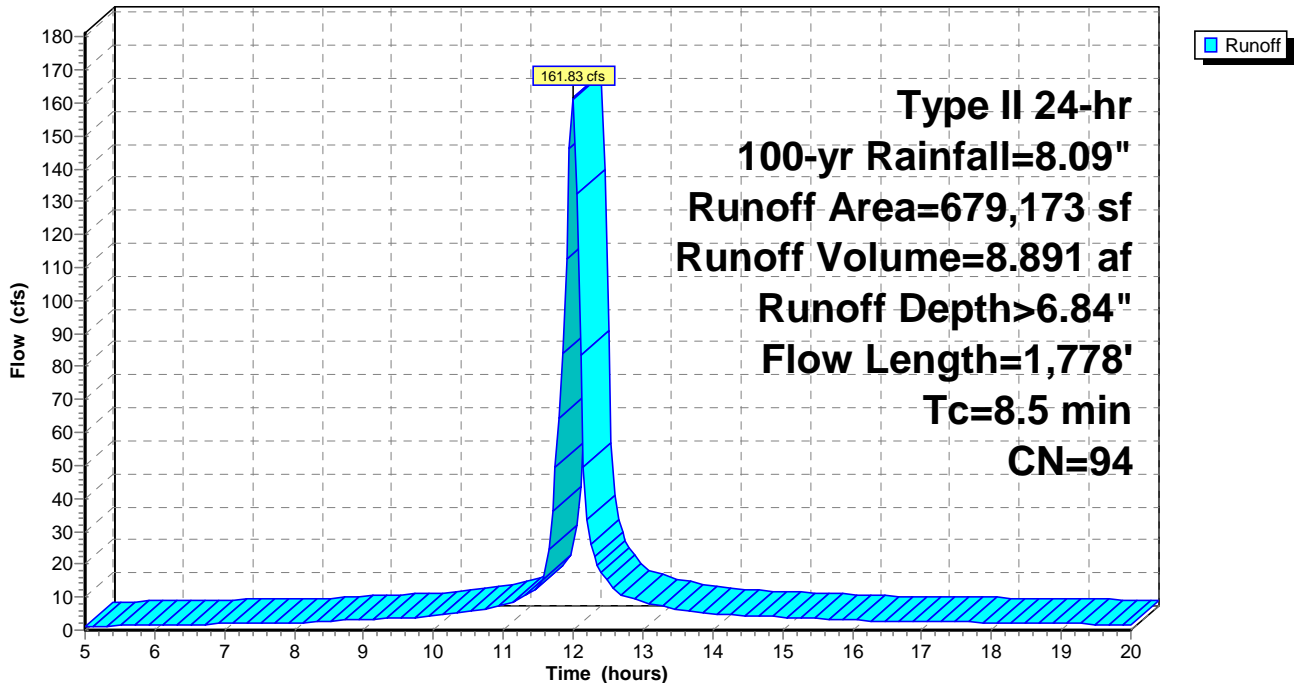

**210730C\_I77\_SEDIMENT\_BASINS**

Prepared by S&ME, Inc.

HydroCAD® 10.00-26 s/n 06707 © 2020 HydroCAD Software Solutions LLC

Type II 24-hr 100-yr Rainfall=8.09"

Printed 3/18/2021

Page 100

**Summary for Subcatchment P1: P-SB-1**

No Channel Flow

Runoff = 389.04 cfs @ 12.05 hrs, Volume= 25.346 af, Depth> 6.84"

Runoff by SCS TR-20 method, UH=SCS, Weighted-CN, Time Span= 5.00-20.00 hrs, dt= 0.05 hrs  
Type II 24-hr 100-yr Rainfall=8.09"

Area (sf)	CN	Description
1,936,988	94	Newly graded area, HSG D
1,936,988		100.00% Pervious Area

Tc (min)	Length (feet)	Slope (ft/ft)	Velocity (ft/sec)	Capacity (cfs)	Description
5.3	300	0.0838	0.95		<b>Sheet Flow,</b> Fallow n= 0.050 P2= 3.54"
7.9	1,294	0.0737	2.71		<b>Shallow Concentrated Flow,</b> Nearly Bare & Untilled Kv= 10.0 fps
0.9	341	0.0045	6.58	230.30	<b>Channel Flow,</b> Area= 35.0 sf Perim= 20.0' r= 1.75' n= 0.022 Earth, clean & straight
14.1	1,935	Total			

**Subcatchment P1: P-SB-1**

Hydrograph

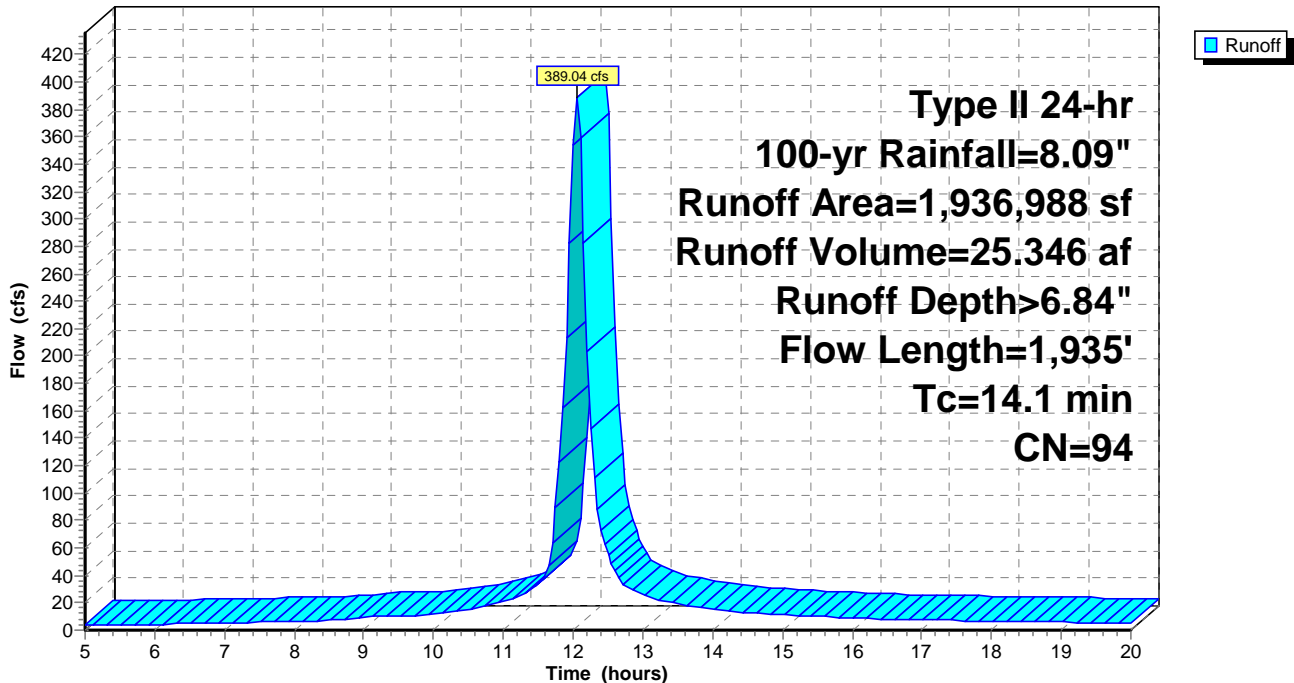

**210730C\_I77\_SEDIMENT\_BASINS**

Prepared by S&ME, Inc.

HydroCAD® 10.00-26 s/n 06707 © 2020 HydroCAD Software Solutions LLC

Type II 24-hr 100-yr Rainfall=8.09"

Printed 3/18/2021

Page 101

**Summary for Subcatchment P2: P-SB-2**

No Channel Flow

Runoff = 143.69 cfs @ 11.99 hrs, Volume= 7.895 af, Depth> 6.84"

Runoff by SCS TR-20 method, UH=SCS, Weighted-CN, Time Span= 5.00-20.00 hrs, dt= 0.05 hrs  
Type II 24-hr 100-yr Rainfall=8.09"

Area (sf)	CN	Description
603,049	94	Newly graded area, HSG D
603,049		100.00% Pervious Area

Tc (min)	Length (feet)	Slope (ft/ft)	Velocity (ft/sec)	Capacity (cfs)	Description
5.2	300	0.0842	0.95		<b>Sheet Flow,</b> Fallow n= 0.050 P2= 3.54"
3.0	582	0.1023	3.20		<b>Shallow Concentrated Flow,</b> Nearly Bare & Untilled Kv= 10.0 fps
0.3	300	0.0240	15.20	531.86	<b>Channel Flow,</b> Area= 35.0 sf Perim= 20.0' r= 1.75' n= 0.022 Earth, clean & straight
8.5	1,182	Total			

**Subcatchment P2: P-SB-2**

Hydrograph

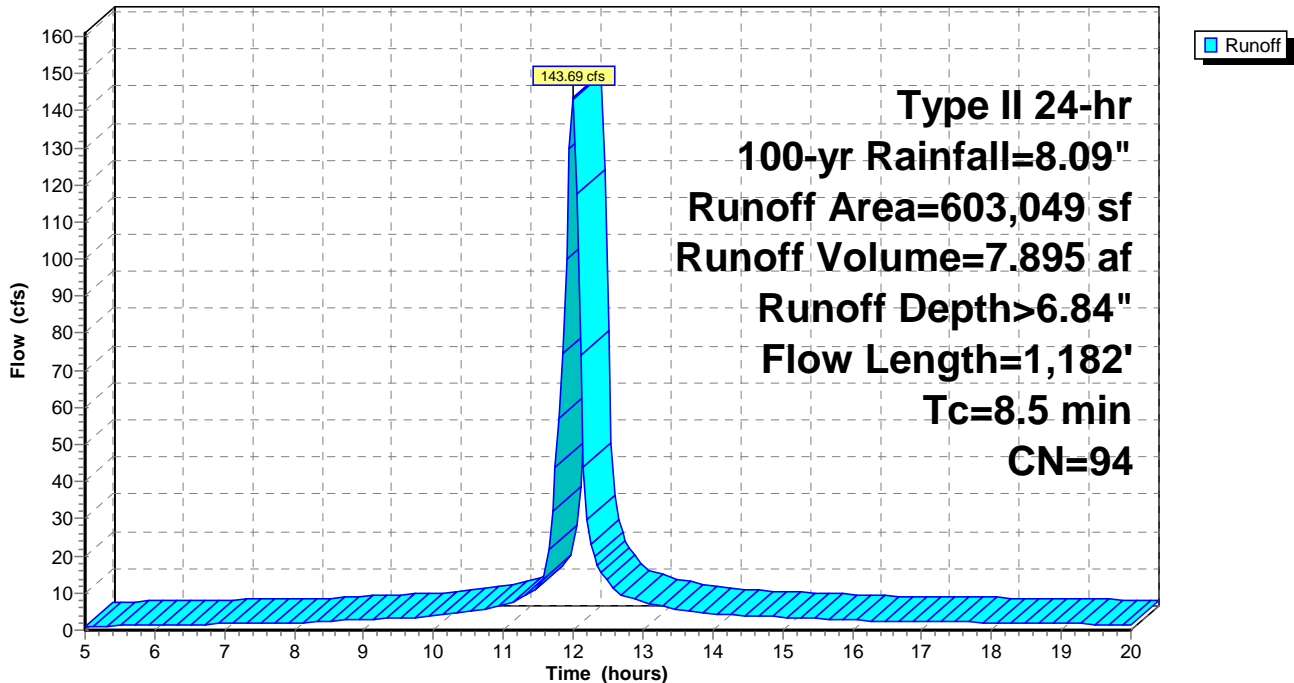

**210730C\_I77\_SEDIMENT\_BASINS**

Prepared by S&ME, Inc.

HydroCAD® 10.00-26 s/n 06707 © 2020 HydroCAD Software Solutions LLC

Type II 24-hr 100-yr Rainfall=8.09"

Printed 3/18/2021

Page 102

**Summary for Subcatchment P3: P-SB-3**

Runoff = 206.12 cfs @ 12.00 hrs, Volume= 11.583 af, Depth> 6.84"

Runoff by SCS TR-20 method, UH=SCS, Weighted-CN, Time Span= 5.00-20.00 hrs, dt= 0.05 hrs  
Type II 24-hr 100-yr Rainfall=8.09"

Area (sf)	CN	Description
884,859	94	Newly graded area, HSG D
884,859		100.00% Pervious Area

Tc (min)	Length (feet)	Slope (ft/ft)	Velocity (ft/sec)	Capacity (cfs)	Description
4.7	300	0.1095	1.06		<b>Sheet Flow,</b> Fallow n= 0.050 P2= 3.54"
4.3	699	0.0738	2.72		<b>Shallow Concentrated Flow,</b> Nearly Bare & Untilled Kv= 10.0 fps
0.2	113	0.0088	9.20	322.06	<b>Channel Flow,</b> Area= 35.0 sf Perim= 20.0' r= 1.75' n= 0.022 Earth, clean & straight
9.2	1,112	Total			

**Subcatchment P3: P-SB-3**

Hydrograph

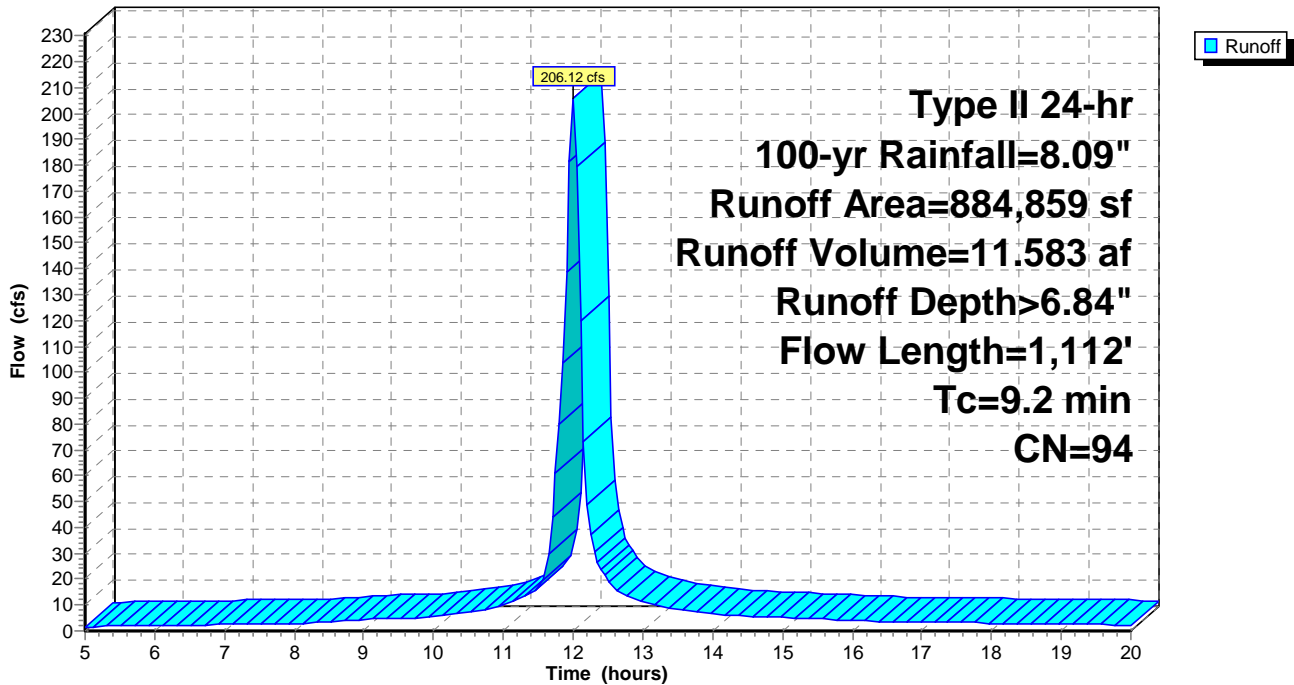

**210730C\_I77\_SEDIMENT\_BASINS**

Prepared by S&ME, Inc.

HydroCAD® 10.00-26 s/n 06707 © 2020 HydroCAD Software Solutions LLC

Type II 24-hr 100-yr Rainfall=8.09"

Printed 3/18/2021

Page 103

**Summary for Subcatchment PT1: PT-SB-1**

No Channel Flow

Runoff = 218.38 cfs @ 12.02 hrs, Volume= 13.250 af, Depth> 6.84"

Runoff by SCS TR-20 method, UH=SCS, Weighted-CN, Time Span= 5.00-20.00 hrs, dt= 0.05 hrs  
Type II 24-hr 100-yr Rainfall=8.09"

Area (sf)	CN	Description
1,012,355	94	Newly graded area, HSG D
1,012,355		100.00% Pervious Area

Tc (min)	Length (feet)	Slope (ft/ft)	Velocity (ft/sec)	Capacity (cfs)	Description
6.2	300	0.0546	0.80		<b>Sheet Flow,</b> Fallow n= 0.050 P2= 3.54"
5.3	804	0.0630	2.51		<b>Shallow Concentrated Flow,</b> Nearly Bare & Untilled Kv= 10.0 fps
11.5	1,104	Total			

**Subcatchment PT1: PT-SB-1**

Hydrograph

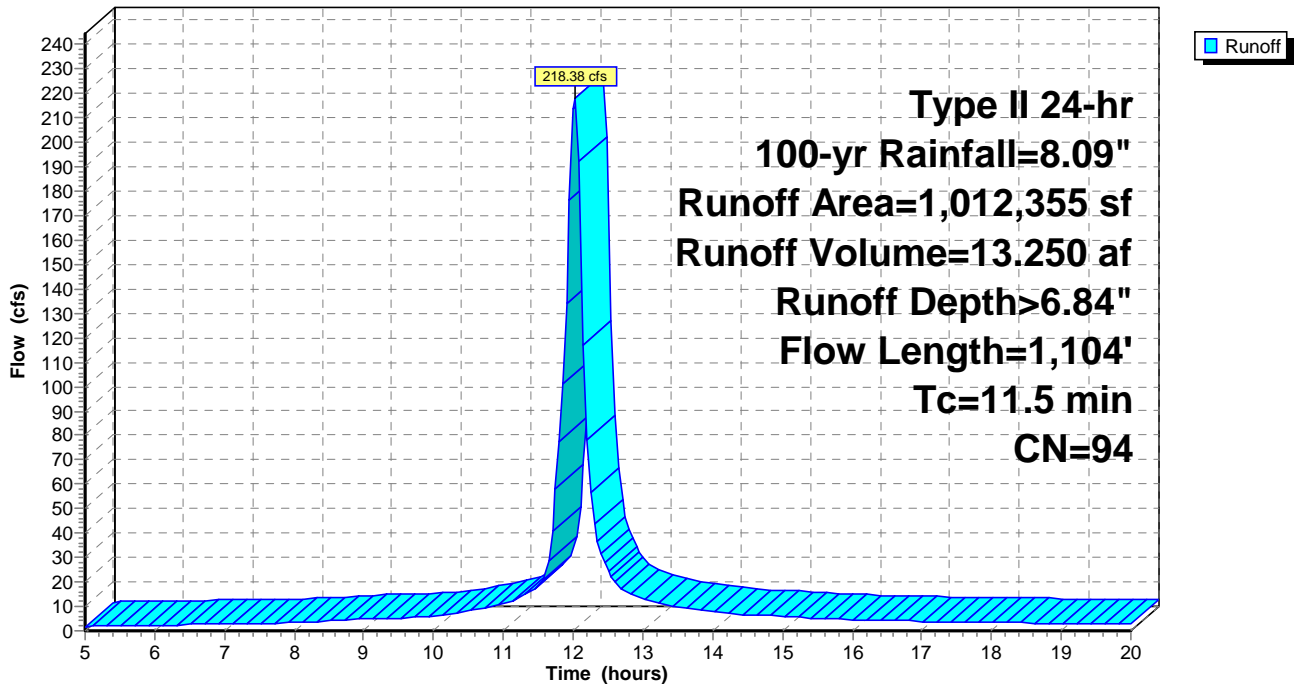



**210730C\_I77\_SEDIMENT\_BASINS**

Prepared by S&ME, Inc.

HydroCAD® 10.00-26 s/n 06707 © 2020 HydroCAD Software Solutions LLC

Type II 24-hr 100-yr Rainfall=8.09"

Printed 3/18/2021

Page 104

**Summary for Subcatchment W1: W-SB-1**

Runoff = 145.49 cfs @ 11.99 hrs, Volume= 7.853 af, Depth> 6.84"

Runoff by SCS TR-20 method, UH=SCS, Weighted-CN, Time Span= 5.00-20.00 hrs, dt= 0.05 hrs  
Type II 24-hr 100-yr Rainfall=8.09"

Area (sf)	CN	Description
599,872	94	Newly graded area, HSG D
599,872		100.00% Pervious Area

Tc (min)	Length (feet)	Slope (ft/ft)	Velocity (ft/sec)	Capacity (cfs)	Description
5.6	300	0.0707	0.89		<b>Sheet Flow,</b> Fallow n= 0.050 P2= 3.54"
1.6	334	0.1196	3.46		<b>Shallow Concentrated Flow,</b> Nearly Bare & Untilled Kv= 10.0 fps
0.7	559	0.0190	13.52	473.22	<b>Channel Flow,</b> Area= 35.0 sf Perim= 20.0' r= 1.75' n= 0.022 Earth, clean & straight

7.9 1,193 Total

**Subcatchment W1: W-SB-1**

Hydrograph

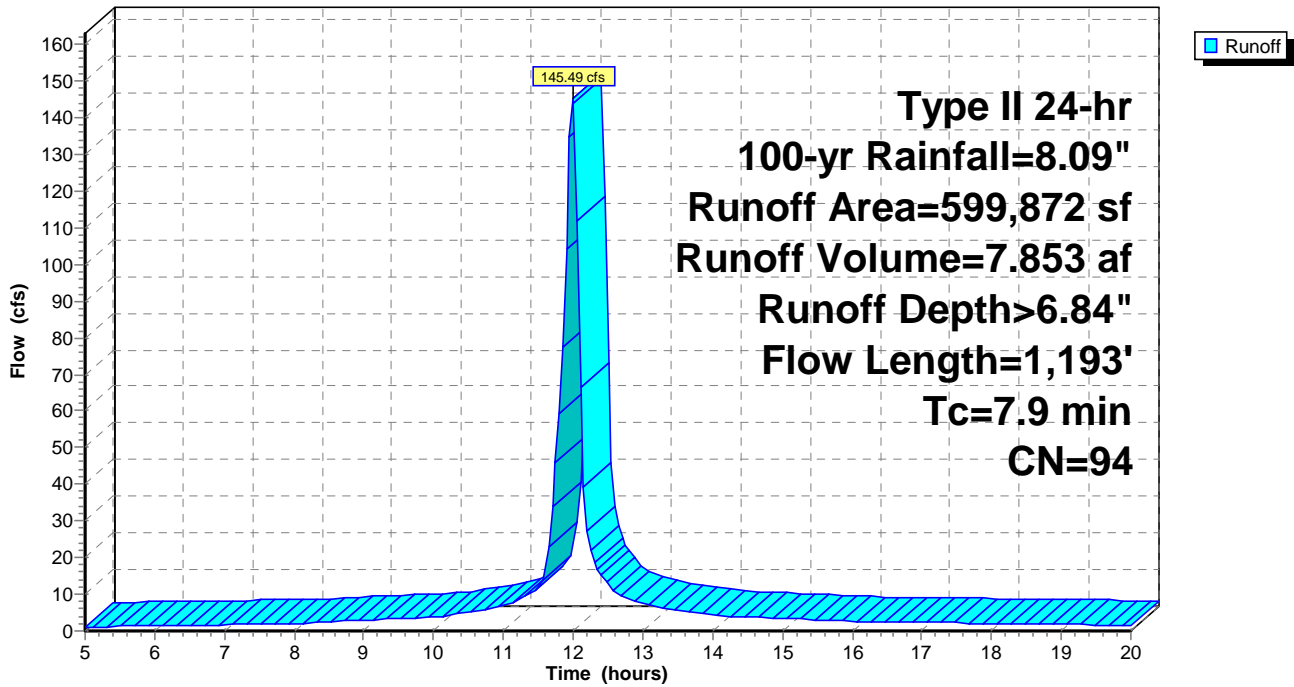

**210730C\_I77\_SEDIMENT\_BASINS**

Type II 24-hr 100-yr Rainfall=8.09"

Prepared by S&ME, Inc.

Printed 3/18/2021

HydroCAD® 10.00-26 s/n 06707 © 2020 HydroCAD Software Solutions LLC

Page 105

**Summary for Pond 1P: P-PT-SB-1**

[82] Warning: Early inflow requires earlier time span

Inflow Area = 23.240 ac, 0.00% Impervious, Inflow Depth > 6.84" for 100-yr event  
 Inflow = 218.38 cfs @ 12.02 hrs, Volume= 13.250 af  
 Outflow = 33.36 cfs @ 12.38 hrs, Volume= 6.153 af, Atten= 85%, Lag= 21.5 min  
 Primary = 33.36 cfs @ 12.38 hrs, Volume= 6.153 af  
 Secondary = 0.00 cfs @ 5.00 hrs, Volume= 0.000 af

Routing by Stor-Ind method, Time Span= 5.00-20.00 hrs, dt= 0.05 hrs  
 Peak Elev= 563.58' @ 12.38 hrs Surf.Area= 66,048 sf Storage= 358,130 cf

Plug-Flow detention time= 195.4 min calculated for 6.149 af (46% of inflow)  
 Center-of-Mass det. time= 102.1 min ( 841.5 - 739.4 )

Volume	Invert	Avail.Storage	Storage Description
#1	557.00'	455,428 cf	<b>Custom Stage Data (Prismatic)</b> Listed below (Recalc)

Elevation (feet)	Surf.Area (sq-ft)	Inc.Store (cubic-feet)	Cum.Store (cubic-feet)
557.00	42,794	0	0
565.00	71,063	455,428	455,428

Device	Routing	Invert	Outlet Devices
#1	Device 2	557.00'	<b>1.168 cfs Constant Flow/Skimmer</b>
#2	Primary	557.00'	<b>24.0" Round Culvert</b> L= 100.0' CMP, square edge headwall, Ke= 0.500 Inlet / Outlet Invert= 557.00' / 556.00' S= 0.0100 '/' Cc= 0.900 n= 0.012 Concrete pipe, finished, Flow Area= 3.14 sf
#3	Device 2	562.70'	<b>36.0" x 36.0" Horiz. Orifice/Grate</b> C= 0.600 Limited to weir flow at low heads
#4	Secondary	563.70'	<b>20.0' long x 12.0' breadth Broad-Crested Rectangular Weir</b> Head (feet) 0.20 0.40 0.60 0.80 1.00 1.20 1.40 1.60 Coef. (English) 2.57 2.62 2.70 2.67 2.66 2.67 2.66 2.64

**Primary OutFlow** Max=33.53 cfs @ 12.38 hrs HW=563.58' (Free Discharge)  
 ↑ **2=Culvert** (Passes 33.53 cfs of 35.73 cfs potential flow)  
 ↑ **1=Constant Flow/Skimmer** (Constant Controls 1.17 cfs)  
 ↑ **3=Orifice/Grate** (Weir Controls 32.36 cfs @ 3.07 fps)

**Secondary OutFlow** Max=0.00 cfs @ 5.00 hrs HW=557.00' (Free Discharge)  
 ↑ **4=Broad-Crested Rectangular Weir** ( Controls 0.00 cfs)

Pond 1P: P-PT-SB-1

Hydrograph

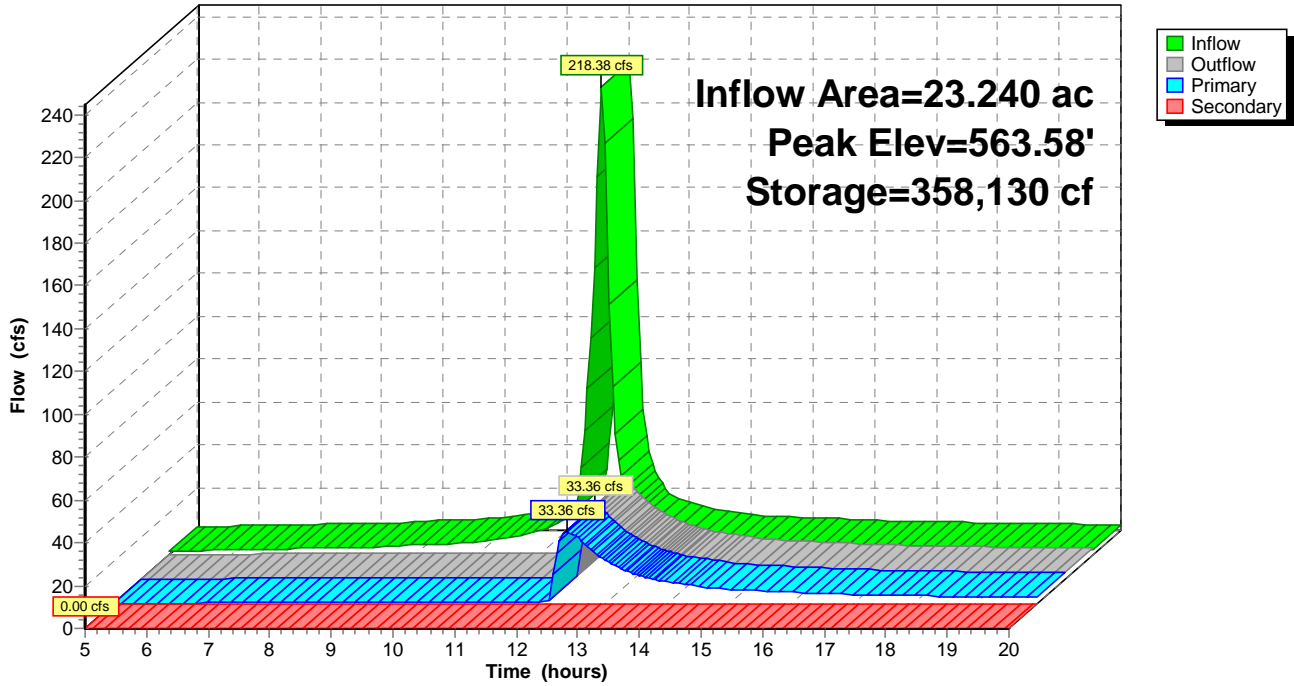

**210730C\_I77\_SEDIMENT\_BASINS**

Type II 24-hr 100-yr Rainfall=8.09"

Prepared by S&ME, Inc.

Printed 3/18/2021

HydroCAD® 10.00-26 s/n 06707 © 2020 HydroCAD Software Solutions LLC

Page 107

**Summary for Pond 2P: P-W-SB-1**

[82] Warning: Early inflow requires earlier time span

Inflow Area = 13.771 ac, 0.00% Impervious, Inflow Depth > 6.84" for 100-yr event  
 Inflow = 145.49 cfs @ 11.99 hrs, Volume= 7.853 af  
 Outflow = 29.49 cfs @ 12.20 hrs, Volume= 3.911 af, Atten= 80%, Lag= 12.8 min  
 Primary = 29.49 cfs @ 12.20 hrs, Volume= 3.911 af  
 Secondary = 0.00 cfs @ 5.00 hrs, Volume= 0.000 af

Routing by Stor-Ind method, Time Span= 5.00-20.00 hrs, dt= 0.05 hrs  
 Peak Elev= 506.21' @ 12.20 hrs Surf.Area= 39,469 sf Storage= 200,363 cf

Plug-Flow detention time= 173.6 min calculated for 3.909 af (50% of inflow)  
 Center-of-Mass det. time= 85.6 min ( 822.3 - 736.7 )

Volume	Invert	Avail.Storage	Storage Description
#1	500.00'	274,756 cf	<b>Custom Stage Data (Prismatic)</b> Listed below (Recalc)

Elevation (feet)	Surf.Area (sq-ft)	Inc.Store (cubic-feet)	Cum.Store (cubic-feet)
500.00	25,066	0	0
508.00	43,623	274,756	274,756

Device	Routing	Invert	Outlet Devices
#1	Device 2	500.00'	<b>0.894 cfs Constant Flow/Skimmer</b>
#2	Primary	500.00'	<b>24.0" Round Culvert</b> L= 100.0' CMP, square edge headwall, Ke= 0.500 Inlet / Outlet Invert= 500.00' / 499.00' S= 0.0100 '/' Cc= 0.900 n= 0.012 Concrete pipe, finished, Flow Area= 3.14 sf
#3	Device 2	505.40'	<b>36.0" x 36.0" Horiz. Orifice/Grate</b> C= 0.600 Limited to weir flow at low heads
#4	Secondary	506.40'	<b>20.0' long x 12.0' breadth Broad-Crested Rectangular Weir</b> Head (feet) 0.20 0.40 0.60 0.80 1.00 1.20 1.40 1.60 Coef. (English) 2.57 2.62 2.70 2.67 2.66 2.67 2.66 2.64

**Primary OutFlow** Max=29.45 cfs @ 12.20 hrs HW=506.21' (Free Discharge)  
 ↑ **2=Culvert** (Passes 29.45 cfs of 34.52 cfs potential flow)  
 ↑ **1=Constant Flow/Skimmer** (Constant Controls 0.89 cfs)  
 ↑ **3=Orifice/Grate** (Weir Controls 28.56 cfs @ 2.94 fps)

**Secondary OutFlow** Max=0.00 cfs @ 5.00 hrs HW=500.00' (Free Discharge)  
 ↑ **4=Broad-Crested Rectangular Weir** ( Controls 0.00 cfs)

**210730C\_I77\_SEDIMENT\_BASINS**

Prepared by S&ME, Inc.

HydroCAD® 10.00-26 s/n 06707 © 2020 HydroCAD Software Solutions LLC

Type II 24-hr 100-yr Rainfall=8.09"

Printed 3/18/2021

Page 108

**Pond 2P: P-W-SB-1**

Hydrograph

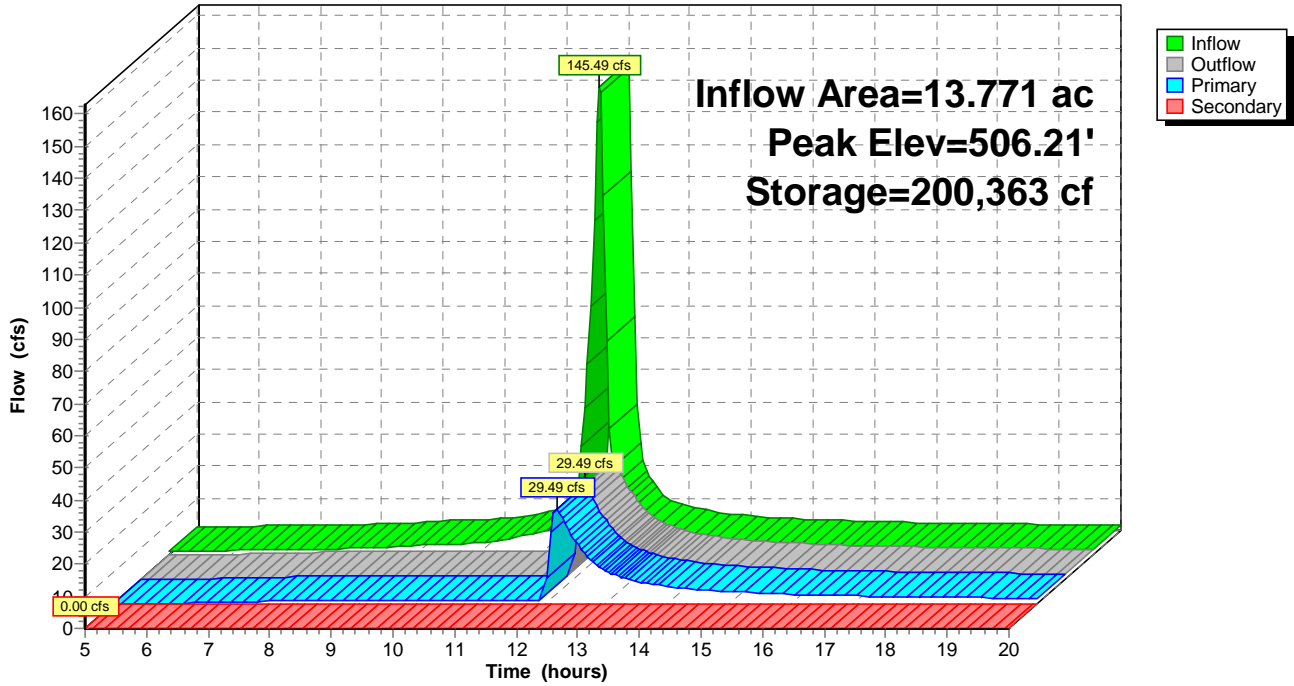

**210730C\_I77\_SEDIMENT\_BASINS**

Type II 24-hr 100-yr Rainfall=8.09"

Prepared by S&ME, Inc.

Printed 3/18/2021

HydroCAD® 10.00-26 s/n 06707 © 2020 HydroCAD Software Solutions LLC

Page 109

**Summary for Pond 3P: P-P-SB-1**

[82] Warning: Early inflow requires earlier time span

Inflow Area = 44.467 ac, 0.00% Impervious, Inflow Depth > 6.84" for 100-yr event  
 Inflow = 389.04 cfs @ 12.05 hrs, Volume= 25.346 af  
 Outflow = 49.88 cfs @ 12.54 hrs, Volume= 11.737 af, Atten= 87%, Lag= 29.3 min  
 Primary = 41.93 cfs @ 12.54 hrs, Volume= 11.435 af  
 Secondary = 7.94 cfs @ 12.54 hrs, Volume= 0.302 af

Routing by Stor-Ind method, Time Span= 5.00-20.00 hrs, dt= 0.05 hrs  
 Peak Elev= 458.69' @ 12.54 hrs Surf.Area= 99,196 sf Storage= 698,442 cf

Plug-Flow detention time= 201.1 min calculated for 11.730 af (46% of inflow)  
 Center-of-Mass det. time= 107.3 min ( 848.7 - 741.3 )

Volume	Invert	Avail.Storage	Storage Description
#1	450.00'	832,615 cf	<b>Custom Stage Data (Prismatic)</b> Listed below (Recalc)

Elevation (feet)	Surf.Area (sq-ft)	Inc.Store (cubic-feet)	Cum.Store (cubic-feet)
450.00	61,641	0	0
460.00	104,882	832,615	832,615

Device	Routing	Invert	Outlet Devices
#1	Device 2	450.00'	<b>1.168 cfs Constant Flow/Skimmer X 2.00</b>
#2	Primary	450.00'	<b>24.0" Round Culvert</b> L= 100.0' CMP, square edge headwall, Ke= 0.500 Inlet / Outlet Invert= 450.00' / 449.00' S= 0.0100 '/' Cc= 0.900 n= 0.012 Concrete pipe, finished, Flow Area= 3.14 sf
#3	Device 2	457.40'	<b>36.0" x 36.0" Horiz. Orifice/Grate</b> C= 0.600 Limited to weir flow at low heads
#4	Secondary	458.40'	<b>20.0' long x 12.0' breadth Broad-Crested Rectangular Weir</b> Head (feet) 0.20 0.40 0.60 0.80 1.00 1.20 1.40 1.60 Coef. (English) 2.57 2.62 2.70 2.67 2.66 2.67 2.66 2.64

**Primary OutFlow** Max=41.93 cfs @ 12.54 hrs HW=458.68' (Free Discharge)

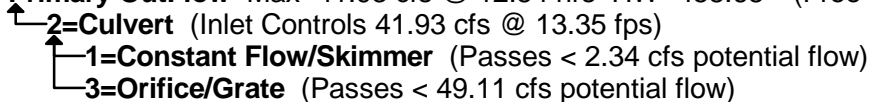

**Secondary OutFlow** Max=7.85 cfs @ 12.54 hrs HW=458.68' (Free Discharge)



Pond 3P: P-P-SB-1

Hydrograph

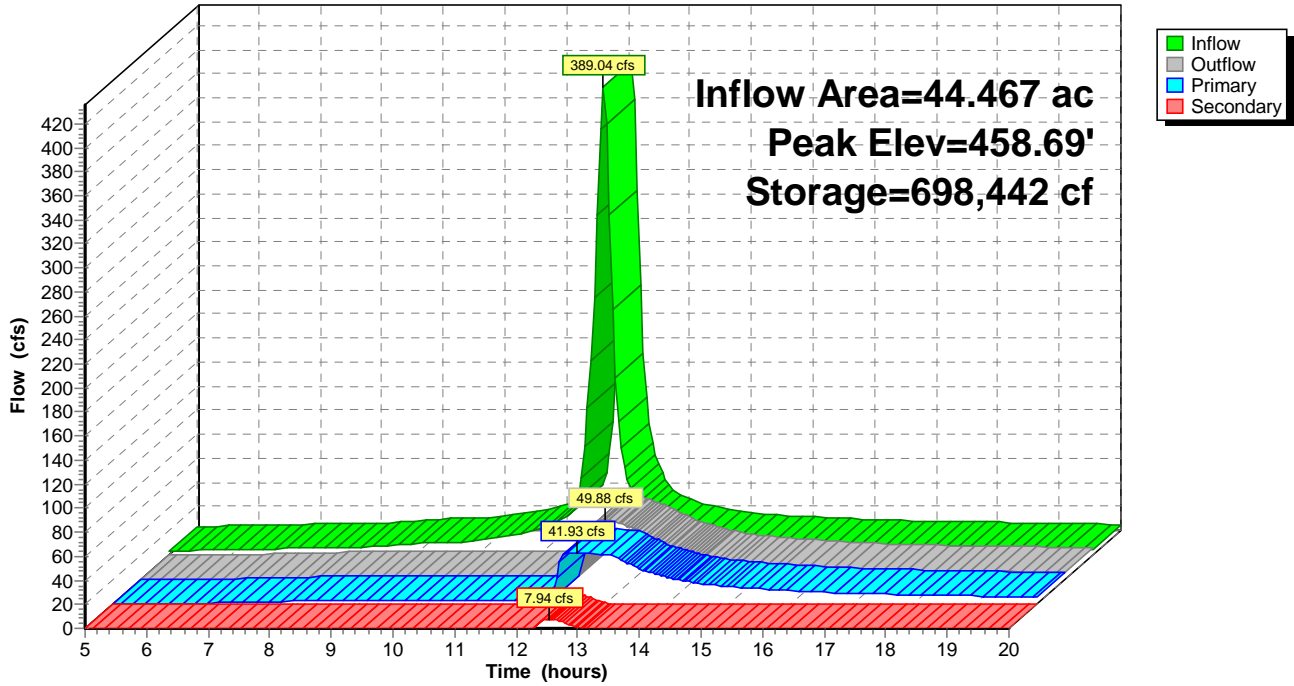

**210730C\_I77\_SEDIMENT\_BASINS**

Type II 24-hr 100-yr Rainfall=8.09"

Prepared by S&ME, Inc.

Printed 3/18/2021

HydroCAD® 10.00-26 s/n 06707 © 2020 HydroCAD Software Solutions LLC

Page 111

**Summary for Pond 4P: P-P-SB-2**

[82] Warning: Early inflow requires earlier time span

Inflow Area = 13.844 ac, 0.00% Impervious, Inflow Depth > 6.84" for 100-yr event  
 Inflow = 143.69 cfs @ 11.99 hrs, Volume= 7.895 af  
 Outflow = 31.71 cfs @ 12.20 hrs, Volume= 3.946 af, Atten= 78%, Lag= 12.7 min  
 Primary = 31.71 cfs @ 12.20 hrs, Volume= 3.946 af  
 Secondary = 0.00 cfs @ 5.00 hrs, Volume= 0.000 af

Routing by Stor-Ind method, Time Span= 5.00-20.00 hrs, dt= 0.05 hrs  
 Peak Elev= 488.25' @ 12.20 hrs Surf.Area= 36,039 sf Storage= 199,432 cf

Plug-Flow detention time= 168.5 min calculated for 3.930 af (50% of inflow)  
 Center-of-Mass det. time= 81.6 min ( 818.8 - 737.2 )

Volume	Invert	Avail.Storage	Storage Description
#1	481.00'	266,076 cf	<b>Custom Stage Data (Prismatic)</b> Listed below (Recalc)

Elevation (feet)	Surf.Area (sq-ft)	Inc.Store (cubic-feet)	Cum.Store (cubic-feet)
481.00	18,972	0	0
490.00	40,156	266,076	266,076

Device	Routing	Invert	Outlet Devices
#1	Device 2	481.00'	<b>0.894 cfs Constant Flow/Skimmer</b>
#2	Primary	481.00'	<b>24.0" Round Culvert</b> L= 100.0' CMP, square edge headwall, Ke= 0.500 Inlet / Outlet Invert= 481.00' / 480.00' S= 0.0100 '/' Cc= 0.900 n= 0.012 Concrete pipe, finished, Flow Area= 3.14 sf
#3	Device 2	487.40'	<b>36.0" x 36.0" Horiz. Orifice/Grate</b> C= 0.600 Limited to weir flow at low heads
#4	Secondary	488.40'	<b>20.0' long x 12.0' breadth Broad-Crested Rectangular Weir</b> Head (feet) 0.20 0.40 0.60 0.80 1.00 1.20 1.40 1.60 Coef. (English) 2.57 2.62 2.70 2.67 2.66 2.67 2.66 2.64

**Primary OutFlow** Max=31.58 cfs @ 12.20 hrs HW=488.25' (Free Discharge)  
 ↑ **2=Culvert** (Passes 31.58 cfs of 37.81 cfs potential flow)  
 ↑ **1=Constant Flow/Skimmer** (Constant Controls 0.89 cfs)  
 ↑ **3=Orifice/Grate** (Weir Controls 30.69 cfs @ 3.01 fps)

**Secondary OutFlow** Max=0.00 cfs @ 5.00 hrs HW=481.00' (Free Discharge)  
 ↑ **4=Broad-Crested Rectangular Weir** ( Controls 0.00 cfs)



**210730C\_I77\_SEDIMENT\_BASINS**

Prepared by S&ME, Inc.

HydroCAD® 10.00-26 s/n 06707 © 2020 HydroCAD Software Solutions LLC

Type II 24-hr 100-yr Rainfall=8.09"

Printed 3/18/2021

Page 112

**Pond 4P: P-P-SB-2**

Hydrograph

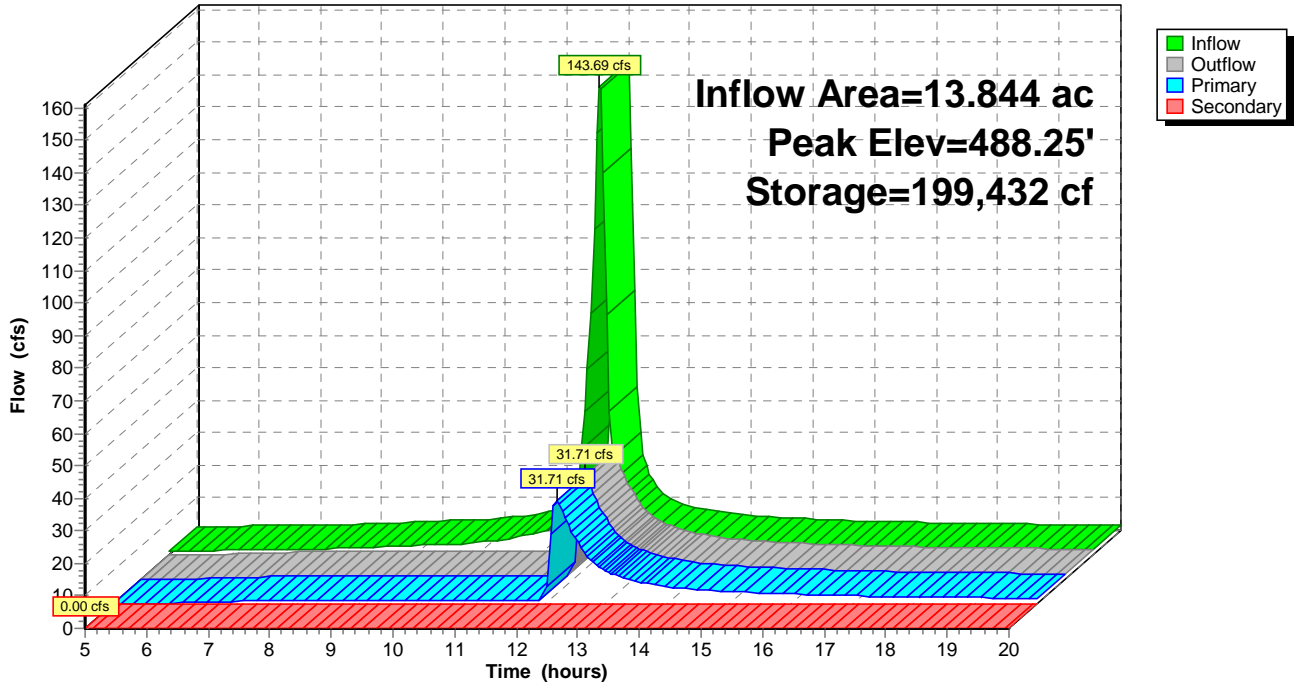

**Summary for Pond 5P: P-P-SB-3**

[82] Warning: Early inflow requires earlier time span

Inflow Area = 20.314 ac, 0.00% Impervious, Inflow Depth > 6.84" for 100-yr event  
 Inflow = 206.12 cfs @ 12.00 hrs, Volume= 11.583 af  
 Outflow = 39.99 cfs @ 12.24 hrs, Volume= 5.653 af, Atten= 81%, Lag= 14.7 min  
 Primary = 39.99 cfs @ 12.24 hrs, Volume= 5.653 af  
 Secondary = 0.00 cfs @ 5.00 hrs, Volume= 0.000 af

Routing by Stor-Ind method, Time Span= 5.00-20.00 hrs, dt= 0.05 hrs  
 Peak Elev= 498.29' @ 12.24 hrs Surf.Area= 47,247 sf Storage= 299,411 cf

Plug-Flow detention time= 176.4 min calculated for 5.631 af (49% of inflow)  
 Center-of-Mass det. time= 87.8 min ( 825.5 - 737.7 )

Volume	Invert	Avail.Storage	Storage Description
#1	490.00'	383,995 cf	<b>Custom Stage Data (Prismatic)</b> Listed below (Recalc)

Elevation (feet)	Surf.Area (sq-ft)	Inc.Store (cubic-feet)	Cum.Store (cubic-feet)
490.00	24,964	0	0
500.00	51,835	383,995	383,995

Device	Routing	Invert	Outlet Devices
#1	Device 2	490.00'	<b>1.168 cfs Constant Flow/Skimmer</b>
#2	Primary	490.00'	<b>24.0" Round Culvert</b> L= 100.0' CMP, square edge headwall, Ke= 0.500 Inlet / Outlet Invert= 490.00' / 489.00' S= 0.0100 '/' Cc= 0.900 n= 0.012 Concrete pipe, finished, Flow Area= 3.14 sf
#3	Device 2	497.30'	<b>36.0" x 36.0" Horiz. Orifice/Grate</b> C= 0.600 Limited to weir flow at low heads
#4	Secondary	498.30'	<b>20.0' long x 12.0' breadth Broad-Crested Rectangular Weir</b> Head (feet) 0.20 0.40 0.60 0.80 1.00 1.20 1.40 1.60 Coef. (English) 2.57 2.62 2.70 2.67 2.66 2.67 2.66 2.64

**Primary OutFlow** Max=39.87 cfs @ 12.24 hrs HW=498.29' (Free Discharge)  
 ↑ **2=Culvert** (Passes 39.87 cfs of 40.84 cfs potential flow)  
 ↑ **1=Constant Flow/Skimmer** (Constant Controls 1.17 cfs)  
 ↑ **3=Orifice/Grate** (Weir Controls 38.71 cfs @ 3.26 fps)

**Secondary OutFlow** Max=0.00 cfs @ 5.00 hrs HW=490.01' (Free Discharge)  
 ↑ **4=Broad-Crested Rectangular Weir** ( Controls 0.00 cfs)

**210730C\_I77\_SEDIMENT\_BASINS**

Prepared by S&ME, Inc.

HydroCAD® 10.00-26 s/n 06707 © 2020 HydroCAD Software Solutions LLC

Type II 24-hr 100-yr Rainfall=8.09"

Printed 3/18/2021

Page 114

**Pond 5P: P-P-SB-3**

Hydrograph

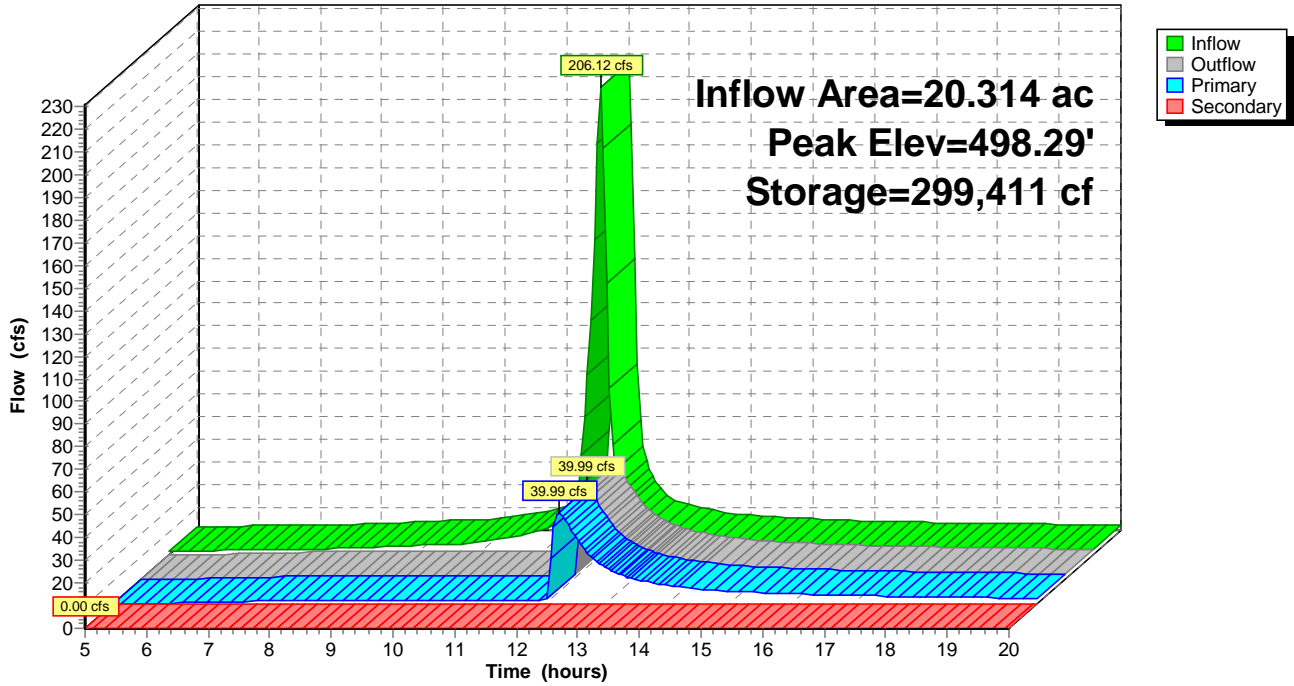

**Summary for Pond 6P: P-NE-SB-1**

[82] Warning: Early inflow requires earlier time span

Inflow Area = 20.801 ac, 0.00% Impervious, Inflow Depth > 6.84" for 100-yr event  
 Inflow = 206.20 cfs @ 12.01 hrs, Volume= 11.860 af  
 Outflow = 38.40 cfs @ 12.27 hrs, Volume= 5.721 af, Atten= 81%, Lag= 16.0 min  
 Primary = 38.40 cfs @ 12.27 hrs, Volume= 5.721 af  
 Secondary = 0.00 cfs @ 5.00 hrs, Volume= 0.000 af

Routing by Stor-Ind method, Time Span= 5.00-20.00 hrs, dt= 0.05 hrs  
 Peak Elev= 435.36' @ 12.27 hrs Surf.Area= 49,424 sf Storage= 308,915 cf

Plug-Flow detention time= 179.0 min calculated for 5.698 af (48% of inflow)  
 Center-of-Mass det. time= 89.5 min ( 827.8 - 738.2 )

Volume	Invert	Avail.Storage	Storage Description
#1	427.00'	393,720 cf	<b>Custom Stage Data (Prismatic)</b> Listed below (Recalc)

Elevation (feet)	Surf.Area (sq-ft)	Inc.Store (cubic-feet)	Cum.Store (cubic-feet)
427.00	24,435	0	0
437.00	54,309	393,720	393,720

Device	Routing	Invert	Outlet Devices
#1	Device 2	427.00'	<b>1.168 cfs Constant Flow/Skimmer</b>
#2	Primary	427.00'	<b>24.0" Round Culvert</b> L= 100.0' CMP, square edge headwall, Ke= 0.500 Inlet / Outlet Invert= 427.00' / 426.00' S= 0.0100 '/' Cc= 0.900 n= 0.012 Concrete pipe, finished, Flow Area= 3.14 sf
#3	Device 2	434.40'	<b>36.0" x 36.0" Horiz. Orifice/Grate</b> C= 0.600 Limited to weir flow at low heads
#4	Secondary	435.40'	<b>20.0' long x 12.0' breadth Broad-Crested Rectangular Weir</b> Head (feet) 0.20 0.40 0.60 0.80 1.00 1.20 1.40 1.60 Coef. (English) 2.57 2.62 2.70 2.67 2.66 2.67 2.66 2.64

**Primary OutFlow** Max=38.04 cfs @ 12.27 hrs HW=435.36' (Free Discharge)  
 ↑ **2=Culvert** (Passes 38.04 cfs of 41.04 cfs potential flow)  
 ↑ **1=Constant Flow/Skimmer** (Constant Controls 1.17 cfs)  
 ↑ **3=Orifice/Grate** (Weir Controls 36.88 cfs @ 3.20 fps)

**Secondary OutFlow** Max=0.00 cfs @ 5.00 hrs HW=427.01' (Free Discharge)  
 ↑ **4=Broad-Crested Rectangular Weir** ( Controls 0.00 cfs)

**210730C\_I77\_SEDIMENT\_BASINS**

Prepared by S&ME, Inc.

HydroCAD® 10.00-26 s/n 06707 © 2020 HydroCAD Software Solutions LLC

Type II 24-hr 100-yr Rainfall=8.09"

Printed 3/18/2021

Page 116

**Pond 6P: P-NE-SB-1**

**Hydrograph**

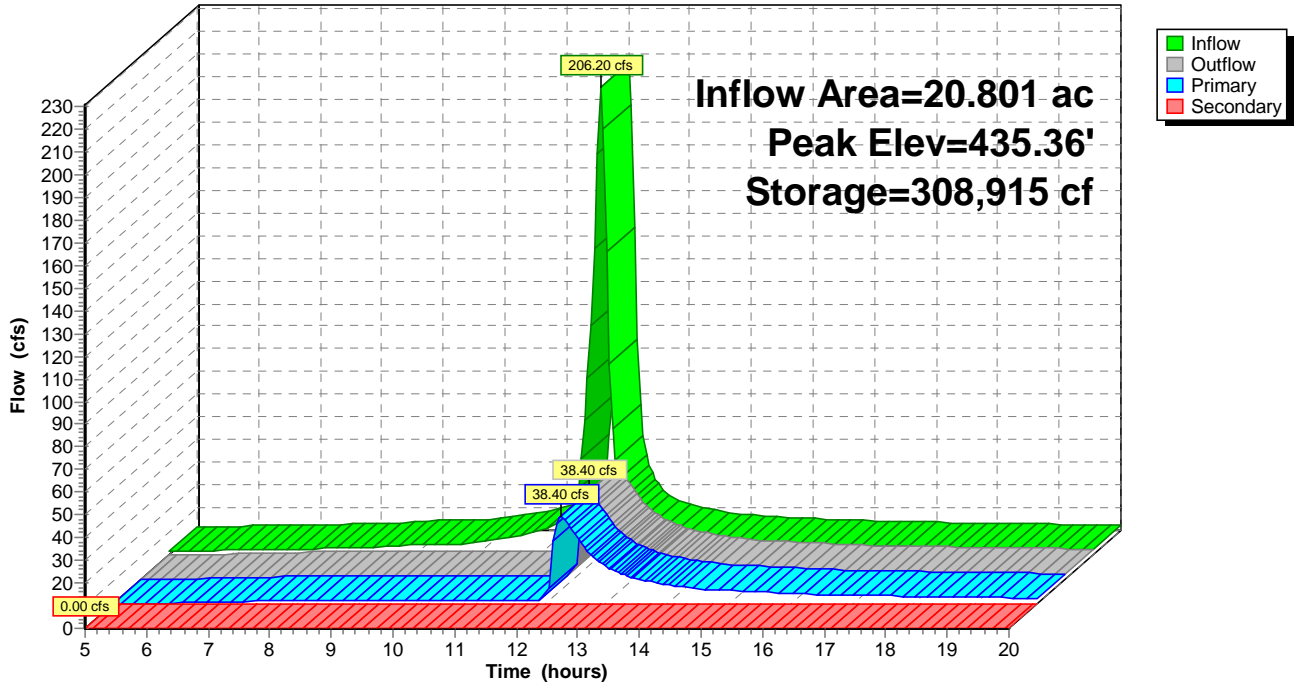

**210730C\_I77\_SEDIMENT\_BASINS**

Type II 24-hr 100-yr Rainfall=8.09"

Prepared by S&ME, Inc.

Printed 3/18/2021

HydroCAD® 10.00-26 s/n 06707 © 2020 HydroCAD Software Solutions LLC

Page 117

**Summary for Pond 7P: P-NE-SB-2**

[82] Warning: Early inflow requires earlier time span

Inflow Area = 7.668 ac, 0.00% Impervious, Inflow Depth > 6.84" for 100-yr event  
 Inflow = 83.52 cfs @ 11.97 hrs, Volume= 4.373 af  
 Outflow = 24.17 cfs @ 12.12 hrs, Volume= 2.336 af, Atten= 71%, Lag= 9.2 min  
 Primary = 24.17 cfs @ 12.12 hrs, Volume= 2.336 af  
 Secondary = 0.00 cfs @ 5.00 hrs, Volume= 0.000 af

Routing by Stor-Ind method, Time Span= 5.00-20.00 hrs, dt= 0.05 hrs  
 Peak Elev= 417.51' @ 12.12 hrs Surf.Area= 24,636 sf Storage= 105,234 cf

Plug-Flow detention time= 152.8 min calculated for 2.327 af (53% of inflow)  
 Center-of-Mass det. time= 70.6 min ( 806.2 - 735.6 )

Volume	Invert	Avail.Storage	Storage Description
#1	412.00'	172,776 cf	<b>Custom Stage Data (Prismatic)</b> Listed below (Recalc)

Elevation (feet)	Surf.Area (sq-ft)	Inc.Store (cubic-feet)	Cum.Store (cubic-feet)
412.00	13,554	0	0
420.00	29,640	172,776	172,776

Device	Routing	Invert	Outlet Devices
#1	Device 2	412.00'	<b>0.657 cfs Constant Flow/Skimmer</b>
#2	Primary	412.00'	<b>24.0" Round Culvert</b> L= 100.0' CMP, square edge headwall, Ke= 0.500 Inlet / Outlet Invert= 412.00' / 411.00' S= 0.0100 '/' Cc= 0.900 n= 0.012 Concrete pipe, finished, Flow Area= 3.14 sf
#3	Device 2	416.80'	<b>36.0" x 36.0" Horiz. Orifice/Grate</b> C= 0.600 Limited to weir flow at low heads
#4	Secondary	417.80'	<b>20.0' long x 12.0' breadth Broad-Crested Rectangular Weir</b> Head (feet) 0.20 0.40 0.60 0.80 1.00 1.20 1.40 1.60 Coef. (English) 2.57 2.62 2.70 2.67 2.66 2.67 2.66 2.64

**Primary OutFlow** Max=23.27 cfs @ 12.12 hrs HW=417.49' (Free Discharge)  
 ↑ **2=Culvert** (Passes 23.27 cfs of 32.06 cfs potential flow)  
 ↑ **1=Constant Flow/Skimmer** (Constant Controls 0.66 cfs)  
 ↑ **3=Orifice/Grate** (Weir Controls 22.61 cfs @ 2.72 fps)

**Secondary OutFlow** Max=0.00 cfs @ 5.00 hrs HW=412.00' (Free Discharge)  
 ↑ **4=Broad-Crested Rectangular Weir** ( Controls 0.00 cfs)

Pond 7P: P-NE-SB-2

Hydrograph

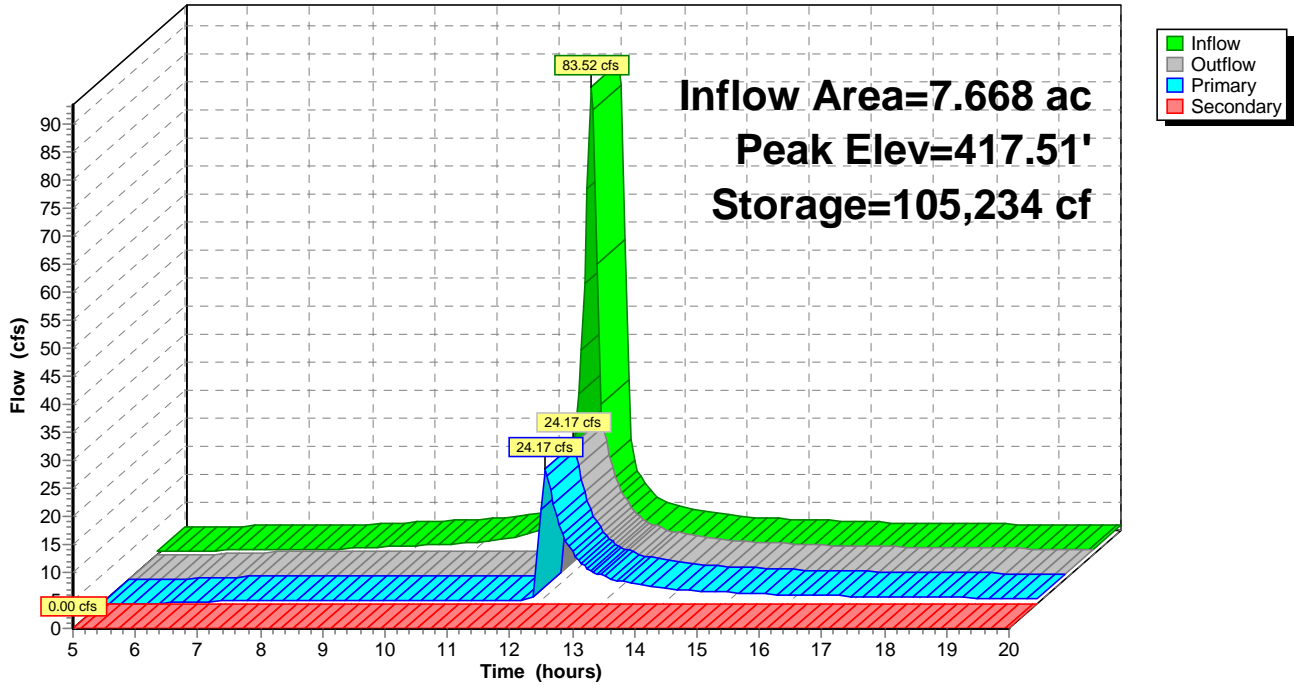

**210730C\_I77\_SEDIMENT\_BASINS**

Type II 24-hr 100-yr Rainfall=8.09"

Prepared by S&ME, Inc.

Printed 3/18/2021

HydroCAD® 10.00-26 s/n 06707 © 2020 HydroCAD Software Solutions LLC

Page 119

**Summary for Pond 8P: P-NE-SB-3**

[82] Warning: Early inflow requires earlier time span

Inflow Area = 10.129 ac, 0.00% Impervious, Inflow Depth > 6.84" for 100-yr event  
 Inflow = 109.26 cfs @ 11.98 hrs, Volume= 5.776 af  
 Outflow = 26.41 cfs @ 12.16 hrs, Volume= 2.914 af, Atten= 76%, Lag= 10.8 min  
 Primary = 26.41 cfs @ 12.16 hrs, Volume= 2.914 af  
 Secondary = 0.00 cfs @ 5.00 hrs, Volume= 0.000 af

Routing by Stor-Ind method, Time Span= 5.00-20.00 hrs, dt= 0.05 hrs  
 Peak Elev= 418.76' @ 12.16 hrs Surf.Area= 28,787 sf Storage= 144,425 cf

Plug-Flow detention time= 164.9 min calculated for 2.903 af (50% of inflow)  
 Center-of-Mass det. time= 78.8 min ( 815.0 - 736.2 )

Volume	Invert	Avail.Storage	Storage Description
#1	412.00'	214,574 cf	<b>Custom Stage Data (Prismatic)</b> Listed below (Recalc)

Elevation (feet)	Surf.Area (sq-ft)	Inc.Store (cubic-feet)	Cum.Store (cubic-feet)
412.00	13,973	0	0
421.00	33,710	214,574	214,574

Device	Routing	Invert	Outlet Devices
#1	Device 2	412.00'	<b>0.657 cfs Constant Flow/Skimmer</b>
#2	Primary	412.00'	<b>24.0" Round Culvert</b> L= 100.0' CMP, square edge headwall, Ke= 0.500 Inlet / Outlet Invert= 412.00' / 411.00' S= 0.0100 '/' Cc= 0.900 n= 0.012 Concrete pipe, finished, Flow Area= 3.14 sf
#3	Device 2	418.00'	<b>36.0" x 36.0" Horiz. Orifice/Grate</b> C= 0.600 Limited to weir flow at low heads
#4	Secondary	419.00'	<b>20.0' long x 12.0' breadth Broad-Crested Rectangular Weir</b> Head (feet) 0.20 0.40 0.60 0.80 1.00 1.20 1.40 1.60 Coef. (English) 2.57 2.62 2.70 2.67 2.66 2.67 2.66 2.64

**Primary OutFlow** Max=26.16 cfs @ 12.16 hrs HW=418.75' (Free Discharge)  
 ↑ **2=Culvert** (Passes 26.16 cfs of 36.27 cfs potential flow)  
 ↑ **1=Constant Flow/Skimmer** (Constant Controls 0.66 cfs)  
 ↑ **3=Orifice/Grate** (Weir Controls 25.50 cfs @ 2.83 fps)

**Secondary OutFlow** Max=0.00 cfs @ 5.00 hrs HW=412.00' (Free Discharge)  
 ↑ **4=Broad-Crested Rectangular Weir** ( Controls 0.00 cfs)



### Pond 8P: P-NE-SB-3

#### Hydrograph

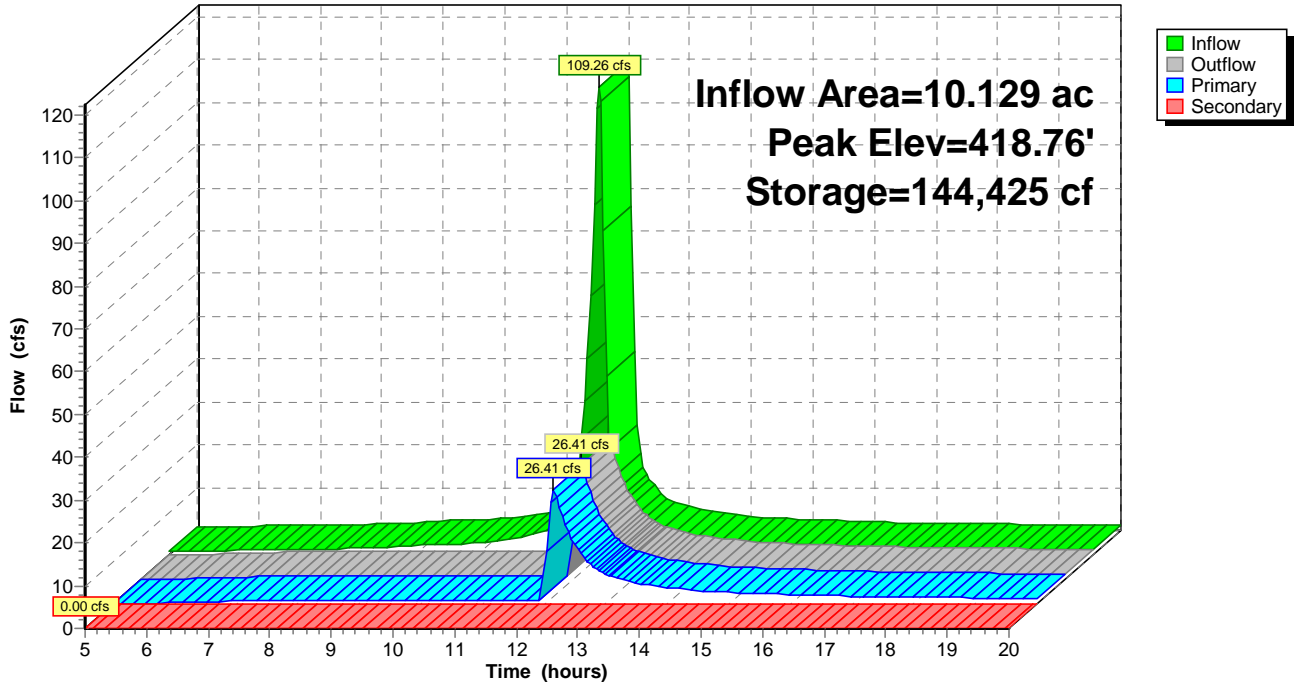

**210730C\_I77\_SEDIMENT\_BASINS**

Type II 24-hr 100-yr Rainfall=8.09"

Prepared by S&ME, Inc.

Printed 3/18/2021

HydroCAD® 10.00-26 s/n 06707 © 2020 HydroCAD Software Solutions LLC

Page 121

**Summary for Pond 9P: P-NE-SB-4**

[82] Warning: Early inflow requires earlier time span

Inflow Area = 15.592 ac, 0.00% Impervious, Inflow Depth > 6.84" for 100-yr event  
 Inflow = 161.83 cfs @ 11.99 hrs, Volume= 8.891 af  
 Outflow = 31.74 cfs @ 12.22 hrs, Volume= 4.478 af, Atten= 80%, Lag= 13.6 min  
 Primary = 31.74 cfs @ 12.22 hrs, Volume= 4.478 af  
 Secondary = 0.00 cfs @ 5.00 hrs, Volume= 0.000 af

Routing by Stor-Ind method, Time Span= 5.00-20.00 hrs, dt= 0.05 hrs  
 Peak Elev= 485.35' @ 12.22 hrs Surf.Area= 43,702 sf Storage= 225,574 cf

Plug-Flow detention time= 170.4 min calculated for 4.460 af (50% of inflow)  
 Center-of-Mass det. time= 84.1 min ( 821.3 - 737.2 )

Volume	Invert	Avail.Storage	Storage Description
#1	479.00'	301,356 cf	<b>Custom Stage Data (Prismatic)</b> Listed below (Recalc)

Elevation (feet)	Surf.Area (sq-ft)	Inc.Store (cubic-feet)	Cum.Store (cubic-feet)
479.00	27,386	0	0
487.00	47,953	301,356	301,356

Device	Routing	Invert	Outlet Devices
#1	Device 2	479.00'	<b>1.168 cfs Constant Flow/Skimmer</b>
#2	Primary	479.00'	<b>24.0" Round Culvert</b> L= 100.0' CMP, square edge headwall, Ke= 0.500 Inlet / Outlet Invert= 479.00' / 478.00' S= 0.0100 '/' Cc= 0.900 n= 0.012 Concrete pipe, finished, Flow Area= 3.14 sf
#3	Device 2	484.50'	<b>36.0" x 36.0" Horiz. Orifice/Grate</b> C= 0.600 Limited to weir flow at low heads
#4	Secondary	485.50'	<b>20.0' long x 12.0' breadth Broad-Crested Rectangular Weir</b> Head (feet) 0.20 0.40 0.60 0.80 1.00 1.20 1.40 1.60 Coef. (English) 2.57 2.62 2.70 2.67 2.66 2.67 2.66 2.64

**Primary OutFlow** Max=31.38 cfs @ 12.22 hrs HW=485.34' (Free Discharge)  
 ↑ **2=Culvert** (Passes 31.38 cfs of 34.96 cfs potential flow)  
 ↑ **1=Constant Flow/Skimmer** (Constant Controls 1.17 cfs)  
 ↑ **3=Orifice/Grate** (Weir Controls 30.21 cfs @ 3.00 fps)

**Secondary OutFlow** Max=0.00 cfs @ 5.00 hrs HW=479.00' (Free Discharge)  
 ↑ **4=Broad-Crested Rectangular Weir** ( Controls 0.00 cfs)

**210730C\_I77\_SEDIMENT\_BASINS**

Prepared by S&ME, Inc.

HydroCAD® 10.00-26 s/n 06707 © 2020 HydroCAD Software Solutions LLC

Type II 24-hr 100-yr Rainfall=8.09"

Printed 3/18/2021

Page 122

**Pond 9P: P-NE-SB-4**

Hydrograph

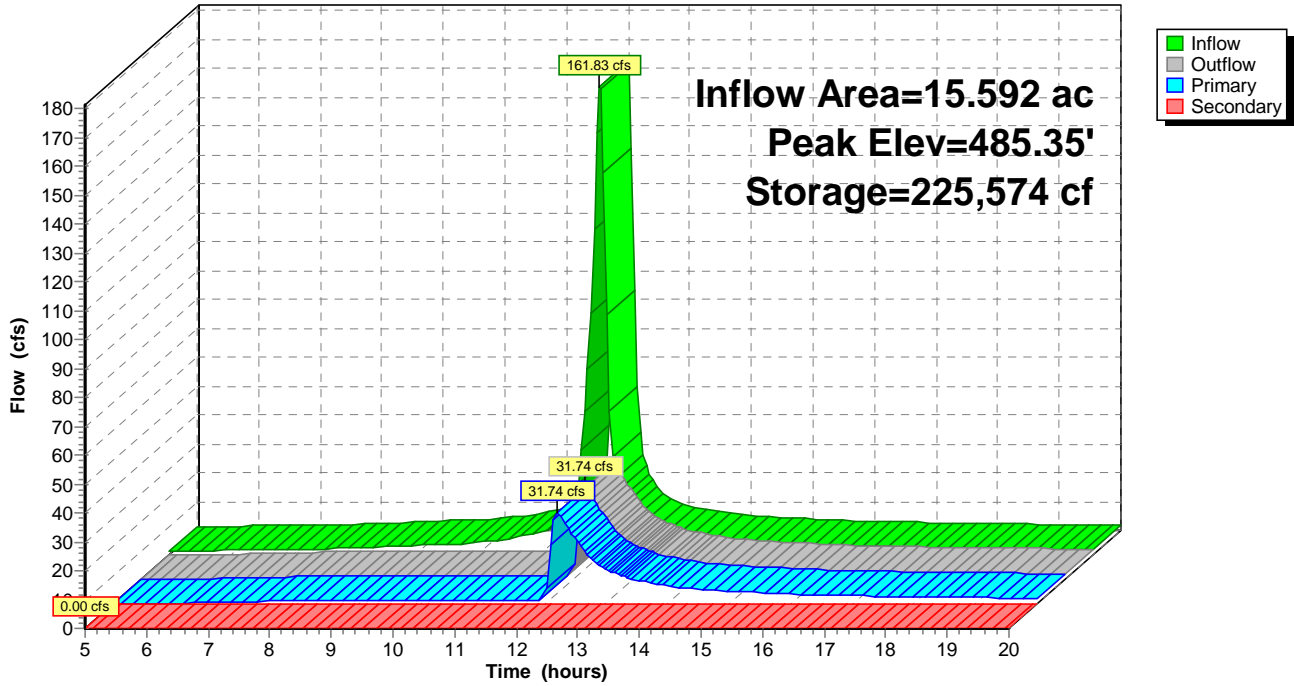

## **Reference 6**

*Compiled SEDIMOT IV Report, S&ME Inc., March 2021.*

## Location Text Results

# Basin: P-SB-1

### Inputs

Name	Value
Location	Northern Greenville County, SC
Region	Greenville Spartanburg

## Design Storm Text Results

### Inputs

Name	Value
Return Period (yr)Type	10 Type II
Precipitation (in.)	5.1
Duration (hrs.)	24.0

## P-SB-1 Text Results

### Hydrology

Name	Value
Peak Flow (cfs)	177.3
Total Runoff Volume (ac-ft)	15.3

### Sediment

Name	Value
Total Sediment Yield (lb)	2400953.8
Average Sediment Discharge Concentration (mg/l)	57810.0
Peak Sediment Discharge Concentration (mg/l)	158472.3
Average Sediment Discharge Turbidity (NTU)	15535.6
Peak Sediment Discharge Turbidity (NTU)	42587.2

## P-SB-1 Text Results

### Hydrology

Name	Value
Total Inflow Volume (ft <sup>3</sup> )	665215.3
Total Outflow Volume (ft <sup>3</sup> )	244300.5
Total Infiltration Volume (ft <sup>3</sup> )	420926.8
Peak Outflow (cfs)	6.3
Drain Time (Hours)	2.25
Peak Stage Elevation (ft)	3.96

### Sediment

Name	Value
------	-------

Total Sediment Mass Inflow (lb)	2400953.8
Clay Mass Inflow (lb)	74909.8
Silt Mass Inflow (lb)	38618.1
Sand Mass Inflow (lb)	836259.6
SmAgg Mass Inflow (lb)	489591.7
LgAgg Mass Inflow (lb)	961574.6
Total Sediment Mass Trapped (lb)	2381695.3
Total Sediment Mass Discharged (lb)	19258.5
Clay Mass Discharged (lb)	17704.2
Silt Mass Discharged (lb)	1554.3
Sand Mass Discharged (lb)	0
SmAgg Mass Discharged (lb)	0
LgAgg Mass Discharged (lb)	0
Sediment Trapping Efficiency (%)	99.2
Clay Trapping Efficiency (%)	76.4
Silt Trapping Efficiency (%)	96
Sand Trapping Efficiency (%)	100
SmAgg Trapping Efficiency (%)	100
LgAgg Trapping Efficiency (%)	100
Average Sediment Discharge Concentration (mg/l)	1262.6
Peak Sediment Discharge Concentration (mg/l)	10066
Average Sediment Discharge Turbidity (NTU)	499.3
Peak Sediment Discharge Turbidity (NTU)	10838.3

## **Reference 7**

SC DHEC Stormwater BMP Handbook, Sediment Control BMPs – Sediment Basins, SC DHEC, Revised March 2014.

# Sediment Basins



## Introduction

Sediment Basins are a Best Management Practice (BMP) used to collect and impound stormwater runoff from disturbed areas (typically 5 acres or more) at construction sites to restrict sediments and other pollutants from being discharged off-site. These basins may also be used to control the volume and velocity of the runoff through a timed release by utilizing multiple spillways. It is through this attenuation of runoff that sediment basins may be capable of meeting South Carolina's Design Requirements, specifically the Total Suspended Solids (TSS) removal efficiency of 80%.

These basins work most effectively in conjunction with additional sediment and erosion control BMPs installed and maintained up gradient of the basins.

## Guidance Disclaimer

*This is a guidance document and may not be feasible in all situations. Alternative means and methods for sediment basin design and construction also may be employed.*

*All means and methods must comply with the DHEC South Carolina NPDES General Permit for Stormwater Discharges from Construction Activities (Permit). Approved means and methods include those published and approved by an MS4 in compliance with the Permit.*

*In addition, a licensed Professional Engineer may design a sediment basin that, when constructed, accommodates the anticipated sediment loading from the land-disturbing activity and meets a removal efficiency of 80% suspended solids or 0.5 ML/L peak settleable solids concentration, whichever is less, while remaining in compliance with the Permit.*

## FEATURES

- Sediment Control
- Volume Control
- Velocity Control

## SECTIONS

- General Design
- Forebays
- Porous Baffles
- Basin Dewatering
- Skimmers
- Spillways
- Permanent Pools
- Maintenance
- Design Aids

## ALSO ADDRESSED

- Inlet Protection
- Basin Safety
- Sediment Storage
- Slope Stabilization
- Rock Berms
- Outlet Protection
- Basin Removal

## PLAN SYMBOL

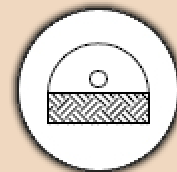



## General Information

Located near the site's perimeters, sediment basins can be created by the building of an embankment or through excavation, when the topography is relatively flat. Careful planning is necessary, during both design and construction phases, to ensure that sediment basins are not placed within Waters of the State (WoS) and are installed prior to the implementation of mass clearing, grubbing, and grading activities.

As runoff discharges into a sediment basin, specific mechanisms are used to reduce the velocity and turbulence of the runoff to allow for settling of suspended particles, a process known as sedimentation. Examples of these mechanisms include sediment forebays, porous baffles, and spillways with outlet structures that only discharge water from near the surface of the water column impounded within the basin.

After construction of the basin, routine inspection and maintenance of sediment basins along with the implementation of additional sediment and erosion control BMPs up gradient of the basin is essential to maintain the required trapping efficiency.



Image Source: Alabama NRCS

## Design Requirements

- TSS Removal Efficiency\* –  $\geq 80\%$
- Peak Settleable Solids Conc.\* –  $\leq 0.5$  mL/L
- Discharge Capacity – 10-yr, 24-hr Storm Event
- Inspections and Maintenance\*\* – Weekly
- Internal Components\*\*\*
- Sediment Forebay – Basin Inlets
- Porous Baffles – Between Inlets & Outlets
- Water Surface Dewatering – Basin Outlets

\* *Whichever is less.* \*\* *Maintenance as necessary per inspection.* \*\*\**Unless Infeasible.*

The above requirements shall serve as a baseline for all sediment basin design within the state of South Carolina. For further reference see SC State Regulations 72.300 Standards for Stormwater Management and Sediment Reduction (Section 72-307.C.5) and the SC NPDES General Permit for Stormwater Discharges from Construction Activities SCR100000 (Section 3.2.6.II).

*The following sections of this guidance can be used to aid in the design of a sediment basin capable of meeting, if not exceeding, the above requirements. The selection and implementation of these practices should be based on the best professional judgment and the conditions expected at the construction site during the lifespan of each sediment basin.*

### **Additional Design Considerations**

- |  |  |
|--|--|
| <input type="checkbox"/> <u>Drainage Area</u> – 5-30 Acres*                            | <input type="checkbox"/> <u>Forebay Volume</u> – 20% Sediment Storage      |
| <input type="checkbox"/> <u>Sediment Storage</u> – 3600 ft <sup>3</sup> /Acre Draining | <input type="checkbox"/> <u>Porous Baffles</u> –3 Rows (Minimum)           |
| <input type="checkbox"/> <u>Min Dewatering Time</u> – 2 days (48 hours)                | <input type="checkbox"/> <u>Basin Inlets</u> – Stabilized to Prevent Scour |
| <input type="checkbox"/> <u>Max Dewatering Time</u> – 5 days (120 hours)               | <input type="checkbox"/> <u>Basin's Bottom Slope</u> – 0.5% or Steeper     |
| <input type="checkbox"/> <u>Basin Shape</u> - L = 2W (Minimum)                         | <input type="checkbox"/> <u>Embankments</u> – 2H:1V or Flatter             |
| <input type="checkbox"/> <u>Cleanout Height</u> - 1/2 Sediment Storage                 |  |

*\*30 Acre Limitation – Based off Design Aids Section. Larger drainage areas may be acceptable when using an alternative methodology to calculated trapping efficiencies.*

### **Location**

The location of sediment basins at a construction site will vary due to site-specific conditions, but the following items should be used as guidance to determine the most appropriate location:

- **Not within Waters of the State:** It is prohibited to construct in or use Waters of the State as a sediment basin.
- **Down Gradient from Major Grading Activities:** Locations down gradient of large scale grading operations will promote sediment control during construction activities.
- **Near Identified Outfalls:** Locations near the determined site outfall will allow sediment basins to collect the majority of the runoff from the disturbed area.
- **Multipurpose Use:** Many construction sites will utilize a sediment basin as a detention pond after construction activities are completed. Selection of an area that allows for the installation of a sediment basin that can be converted to a detention pond post-construction is recommended.
- **Exclude Runoff from Off-Site and Undisturbed Areas:** The placement of sediment basins are recommended at a location that restricts the amount of stormwater runoff impounded from off-site and other undisturbed areas. Placement of temporary diversions berms, swales, or other conveyance measures may be required to divert the "clean" stormwater runoff away from the basin. This practice will minimize the drainage area being served by the sediment basin and may decrease the surface area required by the sediment basin.

### **Safety**

Incorporate all possible safety precautions, such as signs and fencing, for sediment basins that are readily accessible to populated areas. For Example, a lateral shelf that is located above the sediment cleanout elevation may prevent entry onto the accumulated sediment and may also help with maintenance of the basin. In some circumstances, vector control may be necessary for sediment basins that routinely have a standing pool of water. This is especially important around residential areas to inhibit a rise in mosquito populations and the spread of disease. Maintaining a water depth of at least 3 feet within basins with permanent pools may also help prevent a rise in mosquito populations.

All other applicable safety criteria as outlined by the USDA Soil Conservation Service (previously the Natural Resources Conservation Service), the U.S. Army Corps of Engineers, and state Dam Safety Regulations should also be followed during design and construction of sediment basins.

### **Basin Design Criteria**

Properly sizing a sediment basin is crucial to improving sediment control during construction conditions. When designing a basin the following criteria should be addressed:

- **Storage Volume:** The minimum sediment storage volume recommended within a sediment basin is equal to 3,600 cubic feet per acre draining to the basin. Twenty percent (20%) of this volume should be provided within the sediment forebay. (*Basin Volumes of 50 ac-ft or more may be subject to Dam Safety Regulations and Permits.*)
- **Shape:** Sediment basins should be designed to maximize the flow length between the basins' inlets and outlets. To accomplish this, the minimum length-to-width ratio of each basin should be no less than 2:1. This results with an effective flow length that is at least twice the width of the basin. Additional (non-porous) baffling may be required if site constraints prevents the basin from meeting this minimum ratio. In each circumstance, measures must be taken to prevent short-circuiting of the sediment basin. Length and width measurements may be measured from top of embankment.
- **Surface Area:** The surface area within a sediment basin can have a substantial impact on the basin's trapping efficiency. Maximizing the surface area may lead to higher trapping efficiencies and may prove to be very beneficial when employed with multiple rows of porous baffles.
- **Depth:** The provided depth in a sediment basin will be directly linked to the required storage volumes and the appropriate surface area. It is recommended that a depth of 5 - 10 ft be provided in order to maximize surface area within the basin. (*Basin Depths resulting in an embankment height of 25 ft or more may be subject to Dam Safety Regulations and Permits.*)
- **Slope:** The sediment basin's bottom must be graded to have a slope of not less than 0.5%.

### **Basin Dewatering**

Sediment basins must be designed to have the capability to discharge the 10-yr, NRCS 24-hr storm event through the principle spillway while under **during construction** conditions. This spillway must employ a mechanism to withdraw the impounded stormwater runoff from near the surface of the water column impounded within a basin.

This volume of water should discharge through the principle spillway within a time frame of 2-5 days, with 3 days being the recommended target. Meeting this recommended dewatering time allows for finer particulates to fall from suspension, improving the trapping efficiency of the sediment basin.

### **Embankments**

Proper construction and stabilization of basin embankments are important factors of sediment basin design. When designing a basin the following criteria on embankments should be addressed:

- **Construction:** The foundation of the embankment should be stripped and grubbed of all vegetation, stumps, topsoil and other organic matter prior to construction of the dam. Machine compact the soil material used to construct the dam.
- **Minimum Width:** The top width of the embankment should be no less than 5 feet.
- **Side Slopes:** All side slopes, including those located within basin areas that are not part of the embankment, shall be 2:1 (H:V) or flatter. The recommended slope is 3:1 to allow for ease of maintenance.

- **Penetrations:** Any penetrations, including conduits, through the embankment shall be equipped with anti-seep mechanisms, such as anti-seep collars or a core/key trench.
- **Top of Embankment:** Keep the top of the embankment at a minimum of 2 feet above the crest of the principle spillway's riser. (This minimum elevation provides an emergency spillway that is at least 1 foot in height and has a 1-foot separation between its crest and the principle spillway's crest.)
- **Stabilization:** Promptly stabilize all areas disturbed by the construction of the embankment including embankment side slopes and access areas. Temporary or permanent stabilization measures should be conducted as necessary.

### **Excavations**

All sediment basins created or expanded through excavation shall retain side slopes of 2:1 or flatter, and all side slopes should be promptly stabilized to prevent the formation of rills and gullies. The recommended slope is 3:1 (H:V) to allow for ease of maintenance.

### **Inlet Protection**

Inlets into a sediment basin shall be equipped with energy dissipation measures to prevent scour by reducing runoff velocities and/or shall be equipped with stabilization measures designed to handle peak flow conditions. This can be accomplished through the selection and use of BMPs such as riprap aprons, turf reinforcement matting, and plunge pools.

These BMPs should be provided at all inlets into the basin, including inlets that are submerged, and it is recommended that the invert of each inlet is cited to be at the bottom of the sediment basin to prevent erosion along side slopes. When an invert of a basin inlet is not cited at the bottom of the basin, proper conveyance measures should be proposed to allow runoff to enter the basin without eroding the basin's side slopes.

### **Sediment Forebay**

Each sediment basin should be designed to incorporate the use of a sediment forebay, a settling area or impoundment constructed at the incoming points of stormwater runoff that promotes the settling of coarse particulates away from the basin's outlets. Inclusion of a sediment forebay may also help ease maintenance by allowing for the deposition of the larger suspended particles into an easily accessible area away from the principle spillway.

Proper design, construction, and stabilization of each sediment forebay will promote the required functions of sediment basins. When designing a basin the following criteria on forebays should be addressed:

- **Construction:** A riprap berm, gabion, or an earthen berm with a rock filled outlet should be constructed across the bottom of the sediment basin to create a cell within the basin for use as the sediment forebay. The location and height of this berm should be designed to meet the appropriate sediment forebay volume and depth criteria. Alternatively, plunge pools or rock berms may be constructed around each inlet to create a combined volume behind the berms equal to the minimum sediment forebay volume recommendation.
- **Volume:** The minimum volume provided within the forebay(s) should be twenty percent (20%) of the provided sediment storage volume of the basin.

- **Depth:** The depth of the forebay will be dependant upon the required volume. It is recommended to keep the depth between 2 and 4 feet.
- **Accessibility:** Direct access to the forebay will be necessary to allow for routine cleanout of the accumulated sediment. Side slopes adjacent to the forebay may be graded to create a safe path for equipment to access the forebay, or a maintenance ramp or shelf can be incorporated into the basin's design to allow for direct and easy access to all areas of the sediment basin.
- **Clean Out:** A fixed cleanout stake, solely for use within the sediment forebay is recommended near the forebay berm. This cleanout stake is beneficial since the forebay may become inundated with sediment faster than the rest of the basin. The recommended cleanout height for sediment forebays is 1/2 the height of the forebay's berm.



*Photo: Sediment Forebay*

### **Porous Baffles**

Located between the sediment forebay and the basin's spillways (outlets), porous baffles must be installed to aid in the dispersion of runoff across the entire width of the basin and to promote sedimentation by reducing turbulence. Baffles function in basins with or without permanent pools.

Proper design, construction, and stabilization of porous baffles will promote the required functions of sediment basins. When designing a basin the following criteria on porous baffles should be addressed:

- **Height:** The recommended height of each baffle is 3 feet. When possible, the height of each baffle should be equal to or above the 10-yr, 24-hour NRCS Storm's design water surface elevation within the sediment basin.
- **Width:** The width of each baffle shall be equal to the entire width of the sediment basin, including the side slopes up to where the height of the baffle intersects the slope.
- **Spacing:** The minimum spacing between baffles should be 10 feet. Baffles should ultimately be placed to maximize the space between each of the rows of baffles and the basin's sediment forebay/spillways and the adjacent baffle row.
- **Materials:** All porous baffles not composed of turf reinforcement matting (TRM) material should consist of materials derived from coir (coconut fibers) products. An example is coir woven

matting. TRMs should consist of materials that do not have loose Straw fibers. The selected material should have a light penetration (open space) between 10-30%. **Silt Fence may not be used.**

- **Posts:** The posts used to install porous baffles should be steel posts with a minimum weight of 1.25 lb. per liner foot. Install steel posts at a maximum of 4-feet on center.
- **Rows:** A minimum of three (3) porous baffle rows should be installed across the width of the entire basin (including side slopes) where the basin length is greater than 50 feet. For basins with a length of 50 ft or less, only two rows of (2) porous baffles are necessary to be installed.
- **Installation:** All baffles are to be trenched or anchored into the basin's bottom and tied into side slopes to prevent bypass. A rope or wire can be used along the top of the baffle to prevent excessive sagging between the posts.



*Photo: Porous Baffles*

### **Rock Berm**

A rock berm, typically provided in a horseshoe orientation around the principle spillway, may be provided to restrict the deposition of sediment within the area directly adjacent to the principle spillway. Restriction of sedimentation within this area will promote proper skimmer function. This rock berm is not recommended when a permanent pool of water is designed to remain within the basin during construction.

Proper design and construction of a rock berm around the principle spillway will promote the desired functions of sediment basins. When designing a basin the following criteria on rock berms should be addressed:

- **Installation:** The rock berm is to be installed outside the scopes of the skimmer and associated mechanisms required for proper skimmer performance, such as skimmer pits and/or skimmer rock pads. The berm should completely surround the principle spillway and should be installed upon the sediment basin's embankment slopes up to the elevation where the height of the berm intersects the slope.

- **Width:** The width along the crest of the rock berm should be at a minimum of 2 feet. Wider rock berms may be necessary in larger basins.
- **Height:** The height of a rock berm should range between 2-4 feet, dependent upon the height of the basin.



*Photo: Horseshoe Rock Berm Around Principle Spillway with Skimmer*

## **Skimmers**

The most common devices used to meet a sediment basin's surface water dewatering requirements are floating skimmers. These skimmers allow for the dewatering of a basin from the top of the water column up to a specified design elevation, which in South Carolina is the 10-yr, NRCS 24-hr Storm's design Water Surface Elevation (WSE).

The discharge through skimmers will approach a somewhat constant flow rate as the water surface elevation rises within the basin. As the elevation of water rises, the skimmer will remain at the top of the water's surface due to a floatation mechanisms incorporated into skimmer designs by the manufacturer. This floatation is typically designed to keep the depth of water above the skimmer's orifice constant as the water surface elevation rises.

Proper design and installation of skimmers will promote the desired functions of sediment basins. When designing a basin the following criteria on skimmers should be addressed:

- **Installation:** All skimmers should be installed based on manufacturer's recommendation. The skimmer should also be installed prior to clearing and grading of a basin's drainage area.
- **Discharge Capacity:** Each skimmer must be designed/selected to allow the sediment basin to have the capacity to pass the 10-yr, NRCS 24-hr storm event within the recommended time of 2-5 days.
- **Skimmer Size:** The size of the skimmer device, which typically reflects the skimmer's orifice size, should be selected to meet the basin discharge capacity requirements. Most skimmer manufacturers provided skimmer sizes ranging from 1.5" up to 8". Orifice size and associated flow rates are product specific and should be based off product-specific testing.

- **Skimmer Orifice Sizing:** In addition to skimmer size, some skimmer manufacturers provide the option to modify the intake orifice of a skimmer through the use of a plug or flap. These modifications are placed within or over the skimmer's orifice to provide a smaller orifice size.
- **Additional Options:** Dependent on the skimmer manufacturer's recommendations, additional measures may need to be implemented around, near, or under the skimmer to prevent the skimmer from becoming clogged or stuck within deposited sediment. These additional measures included, and may not be limited to, skimmer pits, rock pads, and rope that is attached to the skimmer and then tied to a secure point along the basin's embankment.

A detail of the selected skimmer should be included on the construction site plans that should reference the skimmer's manufacturer, the Daily Discharge Capacity (ft<sup>3</sup>/day), the Average Discharge Rate (cfs), and the Dewatering Time (days). Listing these parameters for each proposed skimmer allows the selection of an equivalent skimmer from an alternative manufacturer, when the need arises.

When selecting an equivalent skimmer, from what was specified on the approved plans, it is important to comply with the following guidance to ensure an "equivalent" skimmer is selected.

- **The Average Discharge Rate (cfs) from the selected skimmer should be equal to or greater than that discharge rate of the approved skimmer.** Any skimmer with a lower Average Discharge Rate would cause the peak water surface elevation within the basin to rise during a given storm event.
- **The Daily Discharge Capacity (ft<sup>3</sup>/day) from the selected skimmer should be equal to or greater than the discharge capacity of the approved skimmer.** Any skimmer with a Daily Discharge Capacity lower than the approved skimmer would cause the peak water surface elevation within the basin to rise during a given storm event.
- **The Dewatering Time should remain within a time frame of 2-5 days.** It is recommended to keep the dewatering time as close to possible to that of the approved skimmer, but complying with this item keeps the basin from dewatering too quickly. The Dewatering Time is equal to the time it takes the skimmer(s) to completely dewater the basin.

Any rise in water surface elevation may allow for more water to flow over the riser crest, increasing the discharge rate of the basin. This potential for increased discharge may reduce the trapping efficiency below the required 80% efficiency.

Failing to follow this guidance would require review and approval of the "equivalent" skimmer prior to implementation (in most cases requiring a Major Modification of the approved plans). All skimmer data should be based off product-specific testing.



*Photo: Skimmer with Attached Rope for Ease of Maintenance*



## Principle Spillway

The Principle Spillway is the primary discharge mechanism for sediment basins. This spillway consists of a riser structure, a barrel (outlet pipe), and surface water dewatering mechanisms (typically a skimmer). The riser structure should also be equipped with a trash rack, an anti-vortex device, and an anti-floatation mechanism.

Proper design and installation of the principle spillway will promote the desired functions of sediment basins. When designing a basin the following criteria on principle spillways should be addressed:

- **Riser:** May be provided as a concrete box/pipe or corrugated pipe. Recommended heights range between 3 and 6 feet.
- **Barrel:** The barrel connects into the riser structure and extends through the basin's embankment to allow impounded stormwater runoff to discharge from the basin. Anti-seep mechanisms must be provided along the barrel to prevent embankment failure.
- **Orifices:** Limit orifices on the riser to those necessary to connect the skimmer device(s). Orifices along the riser in which a skimmer is not connected are not considered to meet the water surface dewatering requirements.
- **Weirs:** Limit the use of weirs along the riser to within 1-foot of the riser crest. Weirs below this elevation are not considered to meet the water surface dewatering requirements.
- **Trash Rack and Anti-Vortex Device:** Equip the riser structure with a trash rack and anti-vortex device to prevent clogging of the principle spillway and non-weir flow over the riser crest.
- **Anti-Floatation Mechanism:** Provide an anchor to prevent floatation of the riser structure. Recommended weight of the anti-floatation mechanism is 1.1 times greater than the weight of the volume of water displaced by the riser structure.
- **10-Yr Design WSE:** The 10-yr design WSE should target the crest of the riser. The maximum head above the riser crest should be limited to 1 foot to maintain water surface dewatering requirements. Basins with permanent pools subject to high ground water tables may be accepted with the 10-yr design WSE more than 1 foot above the riser crest.



*Photo: Principle Spillway's Riser Structure with Skimmer*

## **Emergency Spillway**

The Emergency Spillway is the secondary discharge mechanism for the sediment basin designed to discharge larger storm events, such as the 100-yr, NRCS 24-hr storm event, from the basin. This spillway consists of a stabilized, open channel along the top of the basin's embankment.

Proper design and installation of the emergency spillway will promote the desired functions of sediment basins. When designing a basin the following criteria on emergency spillways should be addressed:

- **Location:** Where feasible, construct the emergency spillway in natural ground and not over fill material.
- **Elevation:** The crest of the emergency spillway should be at least 1 foot below the top of the basin's embankment. This spillway should also be located 1 foot above the crest of the principle spillway's riser or the 10-yr design WSE whichever is higher.
- **Height:** The height should be at least 1 foot and should be designed to successfully pass the 100-yr, NRCS 24-hr storm event with a freeboard of no less than 0.5 feet between the maximum water surface elevation from this storm event and the basin's embankment.
- **Width:** The width of the emergency spillway should be at a minimum of 10 feet.
- **Side Slopes:** The side slopes of the emergency spillway should be no steeper than a 2:1 slope.
- **Stabilization:** The entirety of the emergency spillway, including side slopes and the embankment's slopes, should be properly stabilized. When located on fill material, this stabilization should consist of rip-rap with underlying geotextile fabric or erosion prevention BMPs capable of conveying the expected velocities without failure.

## **Outlet Protection**

Each of the sediment basin's outlets shall be designed to prevent scour and to reduce velocities during peak flow conditions. This can be accomplished through the selection and design of energy dissipation structures such as riprap aprons. Each outlet should also be directed towards pre-existing point source discharges or be equipped with a mechanism to release the discharge as close to sheet flow as possible, to prevent the creation of new point source discharges. Try to restrict the outlets from being placed within 20 linear feet of adjacent properties lines.



*Photo: Principle Spillway's Barrel (Outlet Pipe) with Plunge Pool and Level Spreader*

## **Permanent Pools**

Sediment basins located in low-lying areas or areas with high ground water tables may be incapable of avoiding a standing pool of water within the basin. These conditions may result in a permanent pool of water within the basin during the course of construction activities. Under such conditions, the following design criteria will need to be re-evaluated:

- **Sediment Forebay:** The forebay should be located above the permanent pool elevation when possible. If site-specific constraints are limiting, a forebay may not be capable of being provided. Forebays may not be beneficial when the basin's inlets are submerged and there is little to no overland flow to basin during construction.
- **Rock Berm:** The rock berm may prove ineffective under these circumstances and is not recommended to be provided.
- **Cleanout Height:** Sediment should be removed when approximately  $\frac{1}{2}$  of the sediment storage volume is lost due to accumulated sediment. Removal of sediment will also need to be conducted when the skimmer mechanism fails to rise and fall with the water surface elevation due to sediment accumulation along riser structure.

Additionally many other aspects, including baffles and skimmers, of a sediment basin may prove challenging or infeasible to provide and may require other solutions to design a basin that remains in compliance with South Carolina requirements. This is especially true along the coastal regions of South Carolina where relatively flat topography and high water tables limit the depth of basins.

One option to address such circumstances is the use of a single weir as water surface dewatering mechanism. Allowance of this practice may be dependent upon the following:

- The basin's length-to-width ratio;
- The prevention of short-circuiting between the basin's inlets and outlets;
- Whether or not the basin's inlets are submerged;
- The dispersion of flow within the basin;
- The depth of the permanent pool; and
- The maximum head on the weir crest during the 10-yr, NRCS 24-hr storm event.

Another practice to consider when designing a sediment basin with a permanent pool is turbidity curtains. This practice provides an impermeable liner along the entirety of the water column and only allows flow to discharge near the top of the water surface. Upon proper selection and implementation, turbidity curtains may be capable of enhancing the sedimentation process, dispersion of flow, dewatering from the top of the water surface, and restricting the accumulation of sediment near or around the outlet structure.

The use of these suggested practices must be approved prior to being implemented at the construction site.

## **Inspections & Maintenance**

The key to a functional sediment basin is continual inspections, routine maintenance and regular sediment removal. Each sediment basin should be inspected at a minimum of once every calendar week. It is also recommended to inspect sediment basins within 24 hours of a storm event producing 0.5" of precipitation or greater.

Any deficiencies noted during an inspection of the basin must be addressed within 7 calendar days, before the next scheduled inspection, or before the next storm event.

Over the course of the construction project, accumulated sediment will need to be removed from the basin. Ultimately, the accumulated sediment will need to be removed once it reaches 1/2 of the provided sediment storage volume within the sediment basin but it is recommended to cleanout certain sections of the sediment basin (such as the sediment forebay and the cells between the porous baffles) more frequently. For this reason the following sediment removal procedures may be necessary.

- **Sediment Forebay:** Accumulated sediment should be removed from the forebay when the elevation of the deposited sediment reaches 1/2 the height of the forebay's berm.
- **Porous Baffles' Cells:** Accumulated sediment should be removed from the cells created by each row of baffles when the elevation of the deposited sediment reaches 1/2 the height of the baffles or the cleanout mark located on the cleanout stake, whichever is lower.
- **Rock Berm:** Accumulated sediment should be removed from in front of the rock berm when the elevation of the deposited sediment reaches 1/2 the height of the berm or the cleanout mark located on the cleanout stake, whichever is lower.

When accumulated sediment is removed from a sediment basin, it should be placed in designated stockpile storage areas or spread thinly across the disturbed area and promptly stabilized.

Accumulate sediment is not the only issue that may prevent proper sediment basin functions. Additional maintenance issues that are commonly required to maintain sediment basins are listed in the table located on the following page.

Identified Sediment Basin Condition	Maintenance Measures To Be Taken
Outlet pipe (barrel) is clogged with debris.	Remove debris. Modify trash rack at top of riser structure to restrict larger debris particles from entering the outlet pipe.
Emergency Spillway has eroded due to high discharge velocities during recent storm event.	Stabilize spillway with Erosion Control Blankets (ECBs) or Turf Reinforcement Mats (TRMs) with higher sheer stress capabilities. Alternatively, stabilize spillway with Rip-Rap sized to address anticipated velocities.  Extend stabilization down the embankment's interior and exterior slopes, if not already provided.
Basin's side slopes are eroding. The formation of rills and gullies are evident.	Re-grade slopes and provide proper tracking techniques. Seed slopes and stabilize with ECBs, TRMs, or equivalent erosion prevention BMPs, as necessary. Ensure that the slopes are graded correctly. <b>Do not fill rills/gullies with rip-rap.</b>  Inspect upland areas for evidence of concentrated flows towards slopes. If evident provide a stabilized conveyance method to prevent further erosion along the slope.
Excessive accumulated sediment identified in basin.	Remove sediment to the elevations as denoted on the plans. Place removed sediment in stockpiles or across disturbed areas.
Principle Spillway and Embankment Failure.	Contact regulatory inspection agency. Install temporary BMP measures and stabilize disturbed areas to keep additional impacts to a minimum. Removal of any off-site sediment impacts should be done so at adjacent property owner's consent.
Skimmer is stuck or is clogged with debris.	Use rope to free skimmer from mud. Clear debris from skimmer orifice and install anti-clog mechanism.
Inlets of basin cited for scouring which is increasing erosion within basin.	Stabilize each inlet with Rip-Rap Aprons. Be sure to extend rip-rap above inlet pipe or into inlet channel.

## **Basin Removal**

Sediment Basin may be removed when all areas discharging to the basin have reached final stabilization or when the conditions listed within the approved On-Site SWPPP have been met. In most circumstances, the basin will not be removed but converted to a detention pond to serve the site post-construction.

When a basin is to be removed, it should be completed within 30 days after final site stabilization is achieved or when the approved conditions indicate removal requirements have been met. All areas disturbed as a result of the sediment basin removal will need to be permanently stabilized. Additional BMPs, such as silt fence may need to be utilized to accept runoff from this area until final stabilization is reached.

## **Design Aids**

The following design methodology (Hayes et al. 1995) may be used to design sediment basins to meet the 80 percent trapping efficiency requirements for TSS, which has a drainage area limitation of 30 acres. Alternatively computer models that utilize eroded particle size distributions to calculate a corresponding trapping efficiency may also be used; these models may allow larger drainage areas.

The listed methodology utilizes an eroded particle diameter from on-site soils to determine the settling velocity associated with the soil's specified particle diameter, the surface area of the basin at the riser crest, and the 10-yr, NRCS 24-hr peak outflow from the basin. These three parameters will then be used to calculate a Basin Ratio that can then be used to determine the trapping efficiency from **Figure SB-1** or **SB-2** located in **Appendix K** of SC DHEC's Stormwater BMP Handbook.

Unfortunately, the majority of the available methodologies and computer models may not take into account the anticipated benefits of the various components of the sediment basin, such as water surface withdrawal, porous baffles, and the sediment forebay.

The suggested procedure to determine the trapping efficiency is outlined below.

## **Calculating the Trapping Efficiency of a Sediment Basin**

1. **Determine on-site soils' characteristic eroded particle diameter.** Each soil has a unique eroded particle diameter and the  $D_{15}$  (the particle diameter in which only 15% of the soil particle diameters are less than). To determine the  $D_{15}$  use **Appendix E** of SC DHEC's Stormwater BMP Handbook to look up the smallest  $D_{15}$  listed for all soils identified on-site.
2. **Determine the characteristic settling velocity of on-site soils.** Use **Figure SV-1**, found in **Appendix K**, which plots eroded particle diameter ( $D_{15}$ ) versus settling velocity ( $V_{15}$ ), to determine the value of the settling velocity. This unit is provided in feet per second (fps).
3. **Calculate the Basin Ratio.** Use the provided formula to calculate the Basin Ratio (BR).

$$\text{Basin Ratio} = \frac{q_{po}}{A V_{15}}$$

**Where:**

$q_{po}$  = Peak Outflow Rate from the Basin for the 10-yr, NRCS 24-hr Storm Event (cfs),

$A$  = Surface Area of the Basin at the Riser Crest (acres),

$V_{15}$  = Characteristic Settling Velocity (fps) of the Characteristic  $D_{15}$  Eroded Particle (mm).

4. **Determine Trapping Efficiency.** Use **Figure SB-1** or **Figure SB-2** to determine the trapping efficiency with the Basin Ratio calculated in step 3. These figures plot trapping efficiency versus the basin ratio, and each figure is for separate conditions identified as follows:
- **Figure SB-1** is for basins not located in low lying areas and/or not having a high water table.
  - **Figure SB-2** is for basin located in low lying areas and/or having a high water table. This figure is appropriate for Hydrologic Soil Group (HSG) D soils classified as such due to the presence of a high water table. HSGs A/D, B/D, and C/D are also considered to have high water tables based upon the characteristics of dual hydrologic soil groups.

When using this methodology the following design constraints must be considered:

- Drainage Area to the Sediment Basin must be less than or equal to 30 Acres.
- Overland slope of this drainage area must be less than or equal to 20 percent.
- The sediment basin's Barrel (outlet pipe) must be less than or equal to 6 feet in diameter.
- Any Basin Ratios above the design curves on **Figures SB-1** and **SB-2** are not recommended for any application of the design aids.
- This methodology is not applicable to sediment basins in series.

Additional design guidance on this methodology is as follows:

- If the Basin Ratio intersects the design curve at a point having a trapping efficiency of less than the desired value, the design is inadequate and must be revised.
- A basin, **not** located in low lying area and not having a high water table, has a basin ratio equal to 2.20 E5 at 80 percent trapping efficiency as shown in **Figure SB-1**.
- A basin that **is** located in low lying area and does not have a high water table, has a basin ratio equal to 4.7 E3 at 80 percent trapping efficiency as shown in **Figure SB-2**.

**Design Example**

Design a sediment basin to accept stormwater runoff from a 14-acre (0.0219 mi<sup>2</sup>) construction site during construction conditions. Assume the entire area is disturbed and discharges into the sediment basin. (There are no additional discharges to the basin.) The proposed location of the sediment basin is not located in low-lying areas and does not have a high water table. The only constraint on the size of the basin is to limit the surface area at the basin's riser crest to 0.75 acres. Soil Maps indicate that both Cecil and Edisto soil types are found on-site. Calculate the trapping efficiency of the basin for a 10-year, NRCS 24-hour storm event with and without the use of a skimmer. (The peak discharge from the basin is 8.5 cfs when a skimmer is not employed. Assume that no weir flow occurs across riser crest when skimmer is employed.)

**Skimmer Manufacturer Information**

Skimmer Size	1.5"	2"	2.5"	3"	4"	5"	6"	8"
3 Day Discharge Capacity (Cubic Feet)	5500	10200	19500	31250	64500	102250	165580	298500

**Design Example's Given and Find Information**

Given:

- Drainage Area = 14 Acres (0.0219 mi<sup>2</sup>)
- A = 0.75 Acres (at Riser Crest)
- Cecil and Edisto Soil Types
- Not in Low-Lying Areas.
- There is not a High Water Table.
- Peak Discharge without Skimmer = 8.5 cfs

Find:

- Trapping Efficiency with Skimmer
- Trapping Efficiency without Skimmer

**Solution 1 (No Skimmer):**

1. **Determine D<sub>15</sub>.** From Appendix E, determine the smallest D<sub>15</sub> for both Cecil and Edisto Type Soils.

- a. For Cecil Soils, D<sub>15</sub> = 0.0043 mm
- b. For Edisto Soils, D<sub>15</sub> = 0.0093 mm

Since Cecil has the smallest D<sub>15</sub>, use **0.0043 mm**.

2. **Determine V<sub>15</sub>.** From Appendix K, use Figure SV-1 to determine the V<sub>15</sub>. From this figure and use a D<sub>15</sub> = 0.0043 mm (from step 1), the V<sub>15</sub> will be approximately **5.19 E-05 fps**.

Alternatively, this may be calculated from the following equation  $V_{15}=2.81(D_{15})^2$ . (This equation may only be used if D<sub>15</sub> is less than 0.01 mm.)

3. **Calculate Basin Ratio.** Calculate the Basin Ratio using the given information and the V<sub>15</sub> determined in step 2.

$$BR = \frac{(8.5 \text{ cfs})}{(0.75 \text{ Acres})(5.19 \text{ E-05 fps})}$$

$$BR = 218,368.65$$

4. **Determine Trapping Efficiency.** Determine the trapping efficiency using the calculated BR from step 3 and Figure SB-1 from Appendix K.

$$\text{Trapping Efficiency} = \sim 80\%$$

**Solution 2 (Skimmer):**

1. **Discharge Volume.** The discharge volume could be estimated using the recommended sediment storage volume (3600 cubic feet per acre draining) as the discharge volume but, when known, the volume beneath the riser crest should be used as the discharge volume. For this example the sediment storage volume will be used.

Calculate the required volume that the skimmer must have the capacity to discharge.

$$\text{Discharge Volume} = \frac{3600 \text{ ft}^3}{\text{Acre}} \times 14 \text{ Acres} = 50,400 \text{ ft}^3$$

2. **Calculate 3-Day Skimmer Dewatering Discharge.** Use the calculated discharge volume to select a skimmer based off the provided manufacturer's 3-Day Discharge Capacity. In order to

discharge 50,400 cubic feet within 3 days, select the 4" skimmer since it can discharge 64,500 cubic feet in 3 days.

Determine the average discharge rate through the skimmer in cubic feet per second (cfs) using the 4" skimmer's discharge capacity. (The manufacturer may directly cite the average discharge rate.)

$$\frac{64,500 \text{ ft}^3}{3 \text{ days}} \times \frac{1 \text{ day}}{24 \text{ hrs}} \times \frac{1 \text{ hour}}{60 \text{ mins}} \times \frac{1 \text{ min}}{60 \text{ secs}} = 0.249 \text{ cfs}$$

**Note:** This average discharge rate of 0.249 cfs assumes that water does not overtop the riser crest during the 10-yr storm event. Basin routing should be conducted to confirm this. The peak discharge from the basin will be greater if the Water Surface Elevation (WSE) during this storm event overtops the riser crest. If the WSE is more than 1 foot above the riser crest, a larger or multiple skimmers may be necessary.

3. **Determine D<sub>15</sub>.** From Appendix E, determine the smallest D<sub>15</sub> for both Cecil and Edisto Type Soils.
  - a. For Cecil Soils, D<sub>15</sub> = 0.0043 mm
  - b. For Edisto Soils, D<sub>15</sub> = 0.0093 mm

Since Cecil has the smallest D<sub>15</sub>, use **0.0043 mm**.

4. **Determine V<sub>15</sub>.** From Appendix K, use Figure SV-1 to determine the V<sub>15</sub>. From this figure and use a D<sub>15</sub> = 0.0043 mm (from step 1), the V<sub>15</sub> will be approximately **5.19 E-05 fps**.

Alternatively, this may be calculated from the following equation  $V_{15}=2.81(D_{15})^2$ . (This equation may only be used if D<sub>15</sub> is less than 0.01 mm.)

5. **Calculate Basin Ratio.** Calculate the Basin Ratio using the given information and the V<sub>15</sub> determined in step 2.

$$\text{BR} = \frac{(0.249 \text{ cfs})}{(0.75 \text{ Acres})(5.19 \text{ E-05 fps})}$$

**BR = 6396.92**

6. **Determine Trapping Efficiency.** Determine the trapping efficiency using the calculated BR from step 3 and Figure SB-1 from Appendix K.

**Trapping Efficiency = ~92.5%**



## References

1. Atlanta Regional Commission. Georgia Stormwater Management Manual Volume 2. GPO, 2001. Web.
2. Faircloth, J.W. A Manual for Designing, Installing, and Maintaining Skimmer Sediment Basins. J.W. Faircloth & Son. Nov. 2005. Web. 29 Aug. 2013. <<http://www.fairclothskimmer.com/>>
3. Hann, C.T., B.J. Barfield, and J.C. Hayes. Fundamental of Fluid Mechanics Second Edition. Reading, Massachusetts. Addison-Wesley Publishing Company, 1992.
4. Hayes, J.C. and B.J. Barfield. "Engineering Aids and Design Guidelines for Control of Sediment in South Carolina." In *South Carolina Stormwater and Sediment Control Handbook for Land Disturbance Activities*. GPO, 1995. Web.
5. Idaho Department of Environmental Quality. IDEQ Storm Water Best Management Practices Catalog. GPO, 2005. Web.
6. Iowa Department of Natural Resources. Iowa Stormwater Management Manual. GPO, 2008. Web.
7. Jarret, A.R. Controlling the Dewatering of Sedimentation Basins. *Penn State University Publications*. Agricultural and Biological Engineering. Web. 29 Aug. 2013. <<http://pubs.cas.psu.edu/freepubs/pdfs/f253.pdf>>.
8. Jarret, A.R. Selecting a Faircloth Skimmer. *Penn State University Publications*. Agricultural and Biological Engineering. Web. 29 Aug. 2013. <<http://pubs.cas.psu.edu/freepubs/pdfs/f252.pdf>>.
9. Johns, J.P. Baffles and Surface Water Discharge Design. *UpstateForever.org*. Woolpert, 27 Feb. 2013. Web. 29 Aug. 2013. <<http://www.upstateforever.org/progCAWdocs/2013.02.27BaffleSkimmer.pdf>>.
10. Massachusetts Department of Environmental Protection. Erosion and Sediment Control Guidelines for Urban and Suburban Areas. Northampton, MA. GPO, 1997. Web.
11. Massachusetts Highway Department. *The Mass Highway Storm Water Handbook for Highways and Bridges*. Massachusetts: GPO, 2004. Web.
12. New Hampshire Department of Environmental Services. NH Stormwater Management Manual Volume 2: Post-Construction Best Management Practices Selection and Design. Concord, NH: GPO, 2008. Web.
13. North Carolina Division of Energy, Mineral and Land Resources. North Carolina Erosion and Sediment Control Planning and Design Manual - Chapter 6. GPO, 2013. Web.
14. Pennsylvania Department of Environmental Protection. Erosion and Sediment Pollution Control Program Manual. GPO, 2012. Web.
15. South Carolina Department of Transportation. Supplemental Technical Specification for Porous Baffles. GPO, 2013. Web.
16. Tennessee Department of Environment and Conservation. Erosion and Sediment Control Handbook. GPO, 2012. Web.
17. Urban Drainage and Flood Control District. Urban Storm Drainage Criteria Manual Volume 3. Denver, CO. GPO, 2010. Web.
18. Virginia Department of Conservation and Resources. VA DCR Stormwater Design Specification- Appendix D Sediment Forebay. GPO, 2011. Web.
19. Wisconsin Department of Natural Resources. Storm Water Construction Technical Standards - Sediment Basins. GPO, 2006. Web.

## **Reference 8**

Design Hydrology and Sedimentology for Small Catchments, Haan, C.T., Barfield and Hayes, 1994. Pg. 147-148.

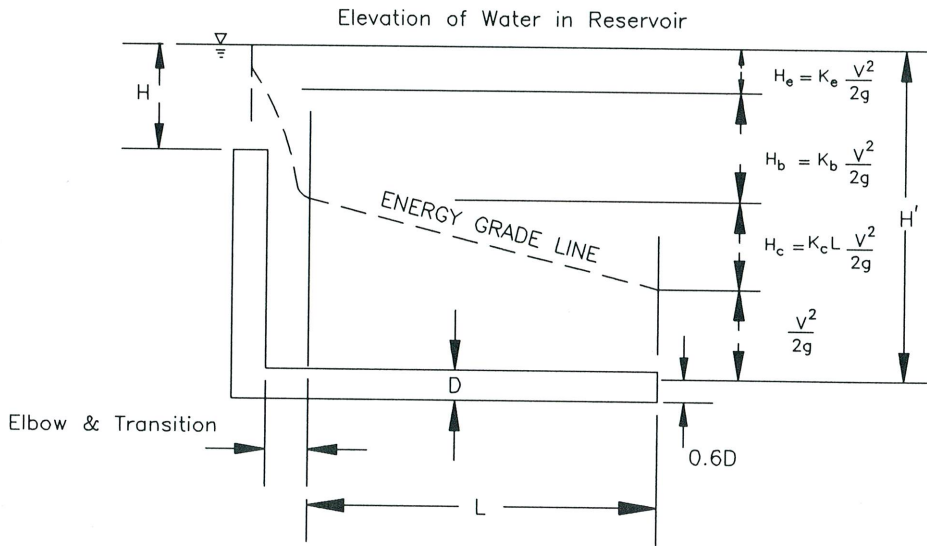

**Figure 5.2** Energy losses for flow in a drop inlet spillway considering bend losses and entrance losses separately.

**Solution:** The discharge under orifice flow will equal

$$Q = C'a(2gH)^{1/2}.$$

The area of 24-in. pipe is 3.14 ft<sup>2</sup>. Assuming a value of 0.6 for  $C'$  since the riser is corrugated metal pipe and substituting values including the gravitational constant, we have

$$Q = 0.6(3.14)\sqrt{2(32.2)H},$$

which reduces to

$$Q = 15.1H^{1/2}.$$

Substituting a head equal to 1 ft into the equation yields  $Q = 15.1$  cfs for orifice flow.

### Pipes as Flow Control Devices

A drop inlet spillway consists of a vertical pipe called a riser and a nearly horizontal pipe called a barrel. This spillway can serve as a flow control device, even when operating under pipe flow. A schematic showing energy losses with pipe flow is given in Fig. 5.2. When the water level shown in Fig. 5.2 rises to a point such that the pipe flows full, the total head causing flow is given by  $H'$  (as shown in Fig. 5.2) instead of  $H$  as it was for weir and orifice control. This head is dissipated as entrance head loss, transition head loss, bend head loss, friction head loss, and velocity head. Frequently, in pipes used to drain detention reservoirs, the only transitions and bends are at the connection between the drop inlet and the bottom pipe. If head losses are given in terms of a head loss coefficient times the

velocity head,  $V^2/2g$ , and the transition and bend head losses are combined into a single head loss term, then the total head  $H'$  can be written as

$$H' = \frac{V^2}{2g} (1 + K_e + K_b + K_c L), \quad (5.4)$$

where  $H'$  is the head on the pipe as shown in Fig. 5.2,  $K_e$  is the entrance head loss coefficient,  $K_b$  is the bend head loss coefficient,  $K_c$  is the head loss coefficient due to friction,  $L$  is the length of the pipe (including the riser), and  $V$  is the mean velocity in the pipe. A schematic showing the head loss terms is given in Fig. 5.2. Since discharge through the pipe is equal to velocity times area, Eq. (5.4) can be solved for discharge as

$$Q = \frac{a(2gH')^{1/2}}{(1 + K_e + K_b + K_c L)^{1/2}}, \quad (5.5)$$

where  $Q$  is discharge and  $a$  is cross-sectional area of the pipe. Values for  $K_c$  are given in Tables 5.1 and 5.2 for circular and square pipes. Values for  $K_e$  and  $K_b$  depend on the configuration of the entrance and the bend. Typical values for  $K_e$  and  $K_b$  are 1.0 and 0.5, respectively. Brater and King (1976), as well as Hoffman (1974), can be consulted for further details.

For risers with rectangular inlets, the bend head losses are frequently combined with the entrance head losses into one term. The total head dissipated through the riser can then be written as

$$H' = \left( \frac{V^2}{2g} \right) (1 + K_e' + K_c L) \quad (5.6)$$

**Table 5.1** Head Loss Coefficients for Circular Conduits Flowing Full<sup>a</sup>

		Head loss coefficient, $K_c$ , for circular pipe flowing full $K_c = 5087 n^2/D^{4/3}$ (Note: Pipe diameter, $D$ , is in inches)															
		Manning's coefficient of roughness, $n$															
Pipe diameter (in.)	Flow area (ft <sup>2</sup> )	0.010	0.011	0.012	0.013	0.014	0.015	0.016	0.017	0.018	0.019	0.020	0.021	0.022	0.023	0.024	0.025
6	0.196	0.0467	0.0565	0.0672	0.0789	0.0914	0.1050	0.1194	0.1348	0.1510	0.1680	0.1870	0.2060	0.2260	0.2470	0.2690	0.2920
8	0.349	0.0318	0.0385	0.0458	0.0537	0.0623	0.0715	0.0814	0.0919	0.1030	0.1148	0.1272	0.1400	0.1540	0.1680	0.1830	0.1990
10	0.545	0.0236	0.0286	0.0340	0.0399	0.0463	0.0531	0.0604	0.0682	0.0765	0.0852	0.0944	0.1041	0.1143	0.1249	0.1360	0.1480
12	0.785	0.0185	0.0224	0.0267	0.0313	0.0363	0.0417	0.0474	0.0535	0.0600	0.0668	0.0741	0.0817	0.0896	0.0980	0.1067	0.1157
14	1.069	0.0151	0.0182	0.0217	0.0255	0.0295	0.0339	0.0386	0.0436	0.0488	0.0544	0.0603	0.0665	0.0730	0.0798	0.0868	0.0942
15	1.230	0.0138	0.0166	0.0198	0.0232	0.0270	0.0309	0.0352	0.0397	0.0446	0.0496	0.0550	0.0606	0.0666	0.0727	0.0792	0.0859
16	1.400	0.0126	0.0153	0.0182	0.0213	0.0247	0.0284	0.0323	0.0365	0.0409	0.0455	0.0505	0.0556	0.0611	0.0667	0.0727	0.0789
18	1.770	0.01078	0.0130	0.0155	0.0182	0.0211	0.0243	0.0276	0.0312	0.0349	0.0389	0.0431	0.0476	0.0522	0.0570	0.0621	0.0674
21	2.410	0.00878	0.01062	0.0126	0.0148	0.0172	0.0198	0.0225	0.0254	0.0284	0.0317	0.0351	0.0387	0.0425	0.0464	0.0506	0.0549
24	3.140	0.00735	0.00889	0.01058	0.0124	0.0144	0.0165	0.0188	0.0212	0.0238	0.0265	0.0294	0.0324	0.0356	0.0389	0.0423	0.0459
27	3.980	0.00628	0.00760	0.00904	0.01061	0.0123	0.0141	0.0161	0.0181	0.0203	0.0227	0.0251	0.0277	0.0304	0.0332	0.0362	0.0393
30	4.910	0.00546	0.00660	0.00786	0.00922	0.01070	0.01228	0.0140	0.0158	0.0177	0.0197	0.0218	0.0241	0.0264	0.0289	0.0314	0.0341
36	7.070	0.00428	0.00518	0.00616	0.00723	0.00839	0.00963	0.01096	0.0124	0.0139	0.0154	0.0171	0.0189	0.0207	0.0226	0.0246	0.0267
42	9.620	0.00348	0.00422	0.00502	0.00589	0.00683	0.00784	0.00892	0.01007	0.01129	0.0126	0.0139	0.0154	0.0169	0.0184	0.0201	0.0218
48	12.570	0.00292	0.00353	0.00420	0.00493	0.00572	0.00656	0.00747	0.00843	0.00945	0.01053	0.01166	0.0129	0.0141	0.0154	0.0168	0.0182
54	15.900	0.00249	0.00302	0.00359	0.00421	0.00488	0.00561	0.00638	0.00720	0.00808	0.00900	0.00997	0.01099	0.0121	0.0132	0.0144	0.0156
60	19.630	0.00217	0.00262	0.00312	0.00366	0.00424	0.00487	0.00554	0.00622	0.00702	0.00782	0.00866	0.00955	0.01048	0.0115	0.0125	0.0135

<sup>a</sup>From Soil Conservation Service (1951).

or

$$Q = \frac{a(2gH')^{1/2}}{(1 + K'_e + K_c L)^{1/2}}, \quad (5.7)$$

where  $K'_e$  is the combined entrance and bend head loss term. By providing a smooth transition, the value for  $K'_e$  can be reduced. Typical values of  $K'_e$  are given in Table 5.3.

Frequently when the drop inlet is the same size as the remainder of the pipe, orifice flow will control, and the pipe will never flow full. In this case, it may be necessary to increase the size of the drop inlet in order to utilize the full capacity of the pipe.

### Example Problem 5.3 Pipe flow

An 24-in.-diameter corrugated metal pipe (CMP) is attached to the 24-in. vertical riser described in Problems 5.1

and 5.2. It is being used as the principal spillway for a detention structure. The pipe is 60 ft long and has one 90° bend. The top of the inlet riser is 15 ft above the bottom of the outlet. Assume a free outfall and estimate the discharge under pipe flow if the water elevation 30 ft from the inlet is 1 ft higher than the top of the riser.

**Solution:** For pipe flow, we have

$$Q = \frac{a(2gH')^{1/2}}{(1 + K_e + K_b + K_c L)^{1/2}}$$

where  $K_e \approx 1.0$  for most entrances of interest and  $K_b = 0.5$ . Manning's  $n$  for CMP is approximately 0.024 (see Table 4.1 for a range of values for CMP). Using this value in Table 5.1,  $K_c = 0.042$ . Head for pipe flow is the distance from the water surface to a point  $0.6D$  above the outlet as shown in Fig. 5.2 and 5.3.  $H'$  then is given in terms of the stage,  $H$ , by

$$H' = H + 15 - 0.6(2.0) = H + 13.8.$$

## **Reference 9**

Determining the Skimmer Size and the Required Orifice, Faircloth Skimmer, November 2007.

# Determining the Skimmer Size and the Required Orifice for the *Faircloth Skimmer*<sup>®</sup> Surface Drain

November 2007

**Important note:** The orifice sizing chart in the Pennsylvania Erosion Control Manual and reproduced in the North Carolina Design Manual **DOES NOT APPLY** to our skimmers. It will give the wrong size orifice and not specify which size skimmer is required. Please use the information below to choose the size skimmer required for the basin volume provided and determine the orifice size required for the drawdown time, typically 4-7 days in Pennsylvania and 3 days in North Carolina.

The **size** of a Faircloth Skimmer<sup>®</sup>, for example a 4" skimmer, refers to the maximum diameter of the skimmer inlet. The inlet on each of the 8 sizes offered can be reduced to adjust the flow rate by cutting a hole or **orifice** in a plug using an adjustable cutter (both supplied).

Determining the skimmer size needed and the orifice for that skimmer required to drain the sediment basin's volume in the required time involves two steps: **First**, determining the size skimmer required based on the volume to be drained and the number of days to drain it; and **Second**, calculate the orifice size to adjust the flow rate and "customize" the skimmer for the basin's volume. *The second step is not always necessary* if the flow rate for the skimmer with the inlet wide open equals or is close to the flow rate required for the basin volume and the drawdown time.

Both the skimmer size and the required orifice radius for the skimmer should be shown for each basin on the erosion and sediment control plan. Make it clear that the dimension is either the radius or the diameter. It is also helpful to give the basin volume in case there are questions. During the skimmer installation the required orifice can be cut in the plastic plug using the supplied adjustable cutter and installed in the skimmer using the instructions provided.

The plan review and enforcement authority may require the calculations showing that the skimmer used can drain the basin in the required time.

## Determining the Skimmer Size

**Step 1.** Below are approximate **skimmer maximum flow capacities** based on typical draw down requirements, which can vary between States and jurisdictions and watersheds. If one 6" skimmer does not provide enough capacity, multiple skimmers can be used to drain the basin. For drawdown times not shown, multiply the 24-hour figure by the number of days required.

**Example:** A basin's volume is 29,600 cubic feet and it must be drained in 3 days. A 3" skimmer with the inlet wide open will work perfectly. (Actually, the chart below gives 29,322 cubic feet but this is well within the accuracy of the calculations and the basin's constructed volume.)

**Example:** A basin's volume is 39,000 cubic feet and it must be drained in 3 days. The 3" skimmer is too small; a 4" skimmer has enough capacity but it is too large, so the inlet will need

to be reduced using step 2 to adjust the flow rate for the basin's volume. (It needs a 3.2" diameter orifice.)

<b>1½" skimmer:</b> with a 1½" head	1,728 cubic feet in <b>24 hours</b> 3,456 cubic feet in <b>2 days</b> 5,184 cubic feet in <b>3 days</b>	6,912 cubic feet in <b>4 days</b> 12,096 cubic feet in <b>7 days</b>
<b>2" skimmer:</b> with a 2" head	3,283 cubic feet in <b>24 hours</b> 6,566 cubic feet in <b>2 days</b> 9,849 cubic feet in <b>3 days</b>	13,132 cubic feet in <b>4 days</b> 22,982 cubic feet in <b>7 days</b>
<b>2½" skimmer:</b> with a 2.5" head Revised 11-6-07	6,234 cubic feet in <b>24 hours</b> 12,468 cubic feet in <b>2 days</b> 18,702 cubic feet in <b>3 days</b>	24,936 cubic feet in <b>4 days</b> 43,638 cubic feet in <b>7 days</b>
<b>3" skimmer:</b> with a 3" head	9,774 cubic feet in <b>24 hours</b> 19,547 cubic feet in <b>2 days</b> 29,322 cubic feet in <b>3 days</b>	39,096 cubic feet in <b>4 days</b> 68,415 cubic feet in <b>7 days</b>
<b>4" skimmer:</b> with a 4" head Revised 11-6-07	20,109 cubic feet in <b>24 hours</b> 40,218 cubic feet in <b>2 days</b> 60,327 cubic feet in <b>3 days</b>	80,436 cubic feet in <b>4 days</b> 140,763 cubic feet in <b>7 days</b>
<b>5" skimmer:</b> with a 4" head	32,832 cubic feet in <b>24 hours</b> 65,664 cubic feet in <b>2 days</b> 98,496 cubic feet in <b>3 days</b>	131,328 cubic feet in <b>4 days</b> 229,824 cubic feet in <b>7 days</b>
<b>6" skimmer:</b> with a 5" head	51,840 cubic feet in <b>24 hours</b> 103,680 cubic feet in <b>2 days</b> 155,520 cubic feet in <b>3 days</b>	207,360 cubic feet in <b>4 days</b> 362,880 cubic feet in <b>7 days</b>
<b>8" skimmer:</b> with a 6" head <b>CUSTOM</b> <b>MADE BY ORDER CALL!</b>	97,978 cubic feet in <b>24 hours</b> 195,956 cubic feet in <b>2 days</b> 293,934 cubic feet in <b>3 days</b>	391,912 cubic feet in <b>4 days</b> 685,846 cubic feet in <b>7 days</b>

## Determining the Orifice

**Step 2.** To determine the orifice required to reduce the flow rate for the basin's volume and the number of days to drain the basin, simply use the formula volume ÷ **factor** (from the chart below) for the same size skimmer chosen in the first step and the same number of days. This calculation will give the **area** of the required orifice. Then calculate the orifice radius using Area =  $\pi r^2$  and solving for  $r$ ,  $r = \sqrt{(Area/3.14)}$ . The supplied cutter can be adjusted to this radius to cut the orifice in the plug. The instructions with the plug and cutter has a ruler divided into tenths of inches. Again, this step is not always necessary as explained above.

An alternative method is to use the orifice equation with the head for a particular skimmer shown on the previous page and determine the orifice needed to give the required flow for the volume and draw down time. C = 0.59 is used in this chart.

**Example:** A 4" skimmer is the smallest skimmer that will drain 39,000 cubic feet in 3 days but a 4" inlet will drain the basin too fast (in 1.9 days) To determine the orifice required use the factor of 4,803 from the chart below for a 4" skimmer and a drawdown time of 3 days. 39,000 cubic

feet ÷ 4,803 = 8.12 square inches of orifice required. Calculate the orifice radius using Area =  $\pi r^2$  and solving for r,  $r = \sqrt{(8.12/3.14)}$  and r = 1.61". As a practical matter 1.6" is about as close as the cutter can be adjusted and the orifice cut..

**Factors** (in cubic feet of flow per square inch of opening through a **round** orifice with the head for that skimmer and for the drawdown times shown) for determining the **orifice radius** for a basin's volume to be drained. This quick method works because the orifice is centered and has a constant head (given above in Step 1).

<b>1½" skimmer:</b>	960 to drain in <b>24 hours</b>	3,840 to drain in <b>4 days</b>
	1,920 to drain in <b>2 days</b>	6,720 to drain in <b>7 days</b>
	2,880 to drain in <b>3 days</b>	
<b>2" skimmer:</b>	1,123 to drain in <b>24 hours</b>	4,492 to drain in <b>4 days</b>
	2,246 to drain in <b>2 days</b>	7,861 to drain in <b>7 days</b>
	3,369 to drain in <b>3 days</b>	
<b>2½" skimmer:</b> Revised 11-6-07	1,270 to drain in <b>24 hours</b>	5,080 to drain in <b>4 days</b>
	2,540 to drain in <b>2 days</b>	8,890 to drain in <b>7 days</b>
	3,810 to drain in <b>3 days</b>	
<b>3" skimmer:</b>	1,382 to drain in <b>24 hours</b>	5,528 to drain in <b>4 days</b>
	2,765 to drain in <b>2 days</b>	9,677 to drain in <b>7 days</b>
	4,146 to drain in <b>3 days</b>	
<b>4" skimmer:</b> Revised 11-6-07	1,601 to drain in <b>24 hours</b>	6,404 to drain in <b>4 days</b>
	3,202 to drain in <b>2 days</b>	11,207 to drain in <b>7 days</b>
	4,803 to drain in <b>3 days</b>	
<b>5" skimmer:</b>	1,642 to drain in <b>24 hours</b>	6,568 to drain in <b>4 days</b>
	3,283 to drain in <b>2 days</b>	11,491 to drain in <b>7 days</b>
	4,926 to drain in <b>3 days</b>	
<b>6" skimmer:</b>	1,814 to drain in <b>24 hours</b>	7,256 to drain in <b>4 days</b>
	3,628 to drain in <b>2 days</b>	12,701 to drain in <b>7 days</b>
	5,442 to drain in <b>3 days</b>	
<b>8" skimmer:</b>	1,987 to drain in <b>24 hours</b>	7,948 to drain in <b>4 days</b>
	3,974 to drain in <b>2 days</b>	13,909 to drain in <b>7 days</b>
	5,961 to drain in <b>3 days</b>	

**J. W. Faircloth & Son, Inc.**  
**Post Office Box 757**  
**412-A Buttonwood Drive**  
**Hillsborough, North Carolina 27278**  
**Telephone (919) 732-1244    FAX (919) 732-1266**  
**FairclothSkimmer.com    jwfaircloth@embarqmail.com**

Orifice sizing    Revised 2-2-01; 3-3-05; 2-1-07; 11-6-07



## **Reference 10**

SC DHEC Stormwater BMP Handbook, Appendix E – South Carolina Soils, SC DHEC, Revised July 2005.

Depth	D15(mm)	K	Particle Sizes (mm)							
			1.4	1.0	0.063	0.044	0.038	0.004	0.003	0.001
SOIL: CECIL (B)										
0 - 7	0.0066	0.28	100.0	84.1	47.9	39.0	39.0	8.1	5.4	0.0
7 - 11	0.0066	0.28	100.0	84.1	47.9	39.0	39.0	8.1	5.4	0.0
11 - 50	0.0043	0.28	100.0	81.0	37.6	36.1	36.1	14.3	10.2	0.0
SOIL: CENTENARY (A)										
0 - 9	0.0465	0.10	100.0	93.3	77.9	3.7	3.7	1.2	0.9	0.0
9 - 58	0.0454	0.10	100.0	93.6	78.9	8.7	8.7	1.4	0.9	0.0
58 - 72	0.0460	0.10	100.0	91.6	72.4	7.1	7.1	1.7	1.2	0.0
SOIL: CHANDLER (B)										
0 - 4	0.0101	0.32	100.0	89.9	66.8	32.7	31.4	3.6	2.2	0.0
4 - 66	0.0101	0.32	100.0	89.9	66.8	32.7	31.4	3.6	2.2	0.0
SOIL: CHARLESTON (C)										
0 - 16	0.0125	0.15	100.0	88.8	63.0	26.4	26.1	3.6	2.2	0.0
16 - 44	0.0128	0.20	100.0	86.4	55.1	25.1	25.1	4.3	2.7	0.0
44 - 80	0.0458	0.15	100.0	89.0	63.7	8.7	8.7	2.4	1.7	0.0
SOIL: CHASTAIN (C)										
0 - 5	0.0049	0.28	100.0	87.8	59.8	54.7	53.6	11.1	7.5	0.0
5 - 52	0.0044	0.37	100.0	87.0	57.3	52.6	51.3	13.3	9.3	0.0
52 - 72	0.0453	0.10	100.0	91.8	73.2	10.1	10.1	1.8	1.2	0.0
SOIL: CHENNEBYPO (C)										
0 - 16	0.0052	0.32	100.0	90.6	69.1	61.8	60.0	9.3	6.0	0.0
16 - 55	0.0056	0.32	100.0	91.5	71.9	61.8	59.9	7.3	4.6	0.0
55 - 72	0.0092	0.24	100.0	84.8	49.9	30.9	30.9	5.7	3.7	0.0
SOIL: CHEWACLA (C)										
0 - 8	0.0056	0.28	100.0	91.1	70.7	59.7	58.8	7.2	4.4	0.0
8 - 24	0.0056	0.32	100.0	88.5	62.1	54.9	54.5	8.2	5.2	0.0
24 - 34	0.0074	0.28	100.0	83.4	45.5	34.6	34.6	7.7	5.2	0.0
34 - 58	0.0056	0.28	100.0	88.5	62.1	54.9	54.5	8.2	5.2	0.0
SOIL: CHIPLEY (C)										
0 - 6	0.0457	0.10	100.0	95.5	85.1	6.6	6.5	0.9	0.6	0.0
6 - 77	0.0459	0.10	100.0	94.1	80.5	6.0	6.0	1.2	0.8	0.0

Depth	D15(mm)	K	Particle Sizes (mm)							
			1.4	1.0	0.063	0.044	0.038	0.004	0.003	0.001
SOIL: ORTEGA (A)										
0 - 5	0.0461	0.15	100.0	96.8	89.6	4.0	4.0	0.6	0.4	0.0
5 - 82	0.0462	0.15	100.0	96.8	89.5	3.0	3.0	0.6	0.4	0.0
SOIL: OSIER (A/D)										
0 - 8	0.0460	0.15	100.0	85.4	52.0	9.8	9.8	3.4	2.4	0.0
8 - 48	0.0456	0.10	100.0	92.3	74.7	8.4	8.4	1.6	1.1	0.0
48 - 75	0.0464	0.05	100.0	94.6	82.3	3.4	3.4	1.0	0.7	0.0
SOIL: OSIERFL (D)										
0 - 8	0.0460	0.15	100.0	85.4	52.0	9.8	9.8	3.4	2.4	0.0
8 - 48	0.0456	0.10	100.0	92.3	74.7	8.4	8.4	1.6	1.1	0.0
48 - 75	0.0464	0.05	100.0	94.6	82.3	3.4	3.4	1.0	0.7	0.0
SOIL: OSIERPO (A/D)										
0 - 8	0.0460	0.15	100.0	85.4	52.0	9.8	9.8	3.4	2.4	0.0
8 - 48	0.0462	0.10	100.0	89.9	66.7	7.0	7.0	2.1	1.5	0.0
48 - 75	0.0464	0.05	100.0	94.6	82.3	3.4	3.4	1.0	0.7	0.0
SOIL: PACOLET (B)										
0 - 3	0.0121	0.24	100.0	80.2	35.0	22.6	22.6	7.6	5.4	0.0
3 - 29	0.0053	0.28	100.0	78.1	28.2	26.0	26.0	13.4	9.8	0.0
29 - 52	0.0092	0.28	100.0	83.4	45.6	29.4	29.4	6.5	4.4	0.0
52 - 70	0.0113	0.28	100.0	84.7	49.6	25.0	25.0	5.1	3.4	0.0
SOIL: PACOLETGR (B)										
0 - 3	0.0143	0.20	100.0	78.7	30.0	20.1	20.1	8.4	6.0	0.0
3 - 29	0.0053	0.28	100.0	78.1	28.2	26.0	26.0	13.4	9.8	0.0
29 - 52	0.0092	0.28	100.0	83.4	45.6	29.4	29.4	6.5	4.4	0.0
52 - 70	0.0113	0.28	100.0	84.8	50.1	26.4	26.4	5.2	3.4	0.0
SOIL: PACTOLUS (A)										
0 - 40	0.0444	0.10	100.0	91.2	71.0	13.6	13.6	2.2	1.4	0.0
40 - 80	0.0445	0.10	100.0	91.2	71.1	13.3	13.3	2.2	1.4	0.0

## **Reference 11**

SC DHEC Stormwater MP Handbook, Appendix K – Figures, SC DHEC, Revised July 2005.

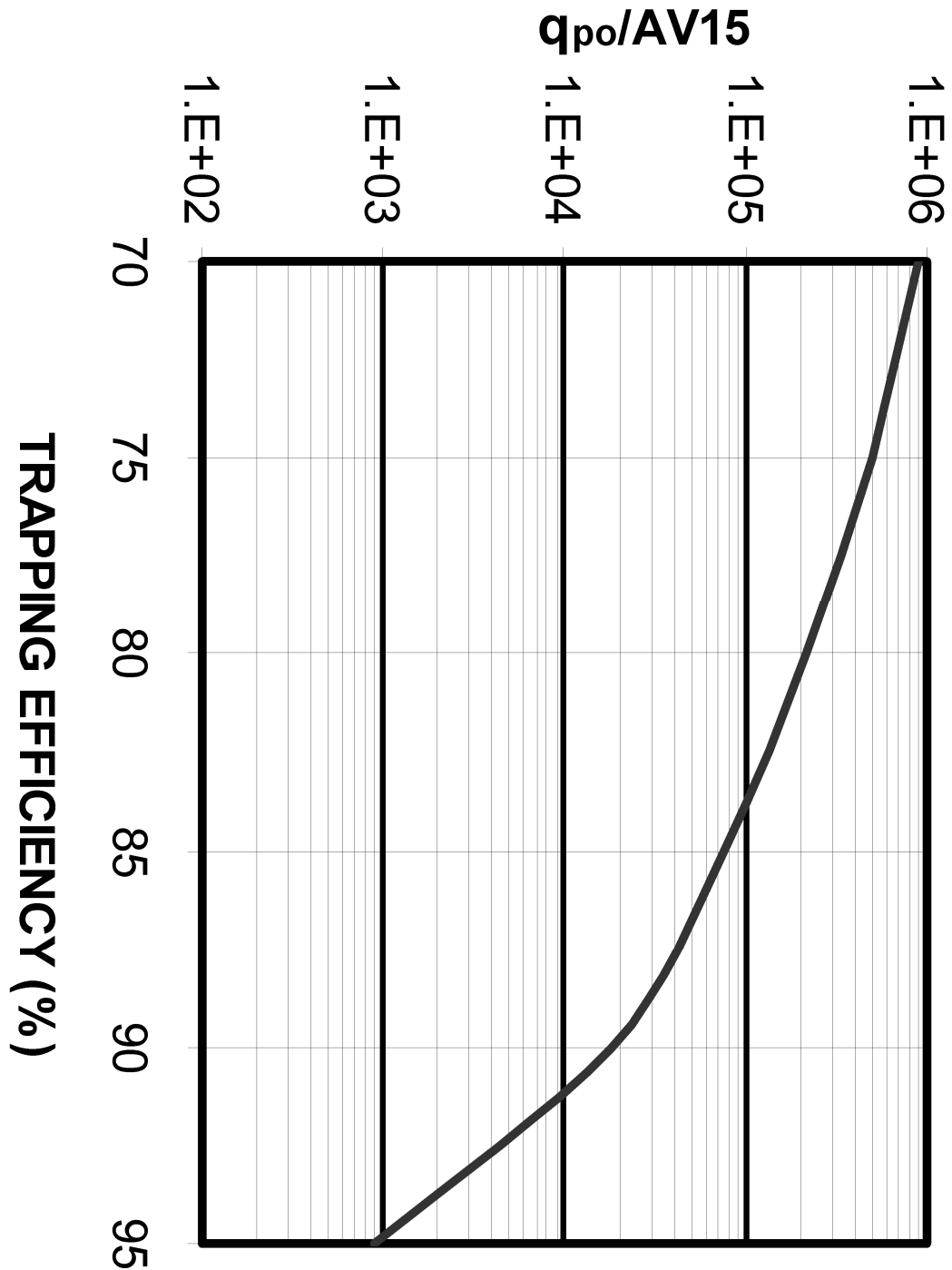

**DESIGN AID FOR ESTIMATING TRAPPING EFFICIENCY  
FOR SEDIMENT BASINS NOT LOCATED IN LOW LYING  
AREAS AND/OR NOT HAVING A HIGH WATER TABLE**

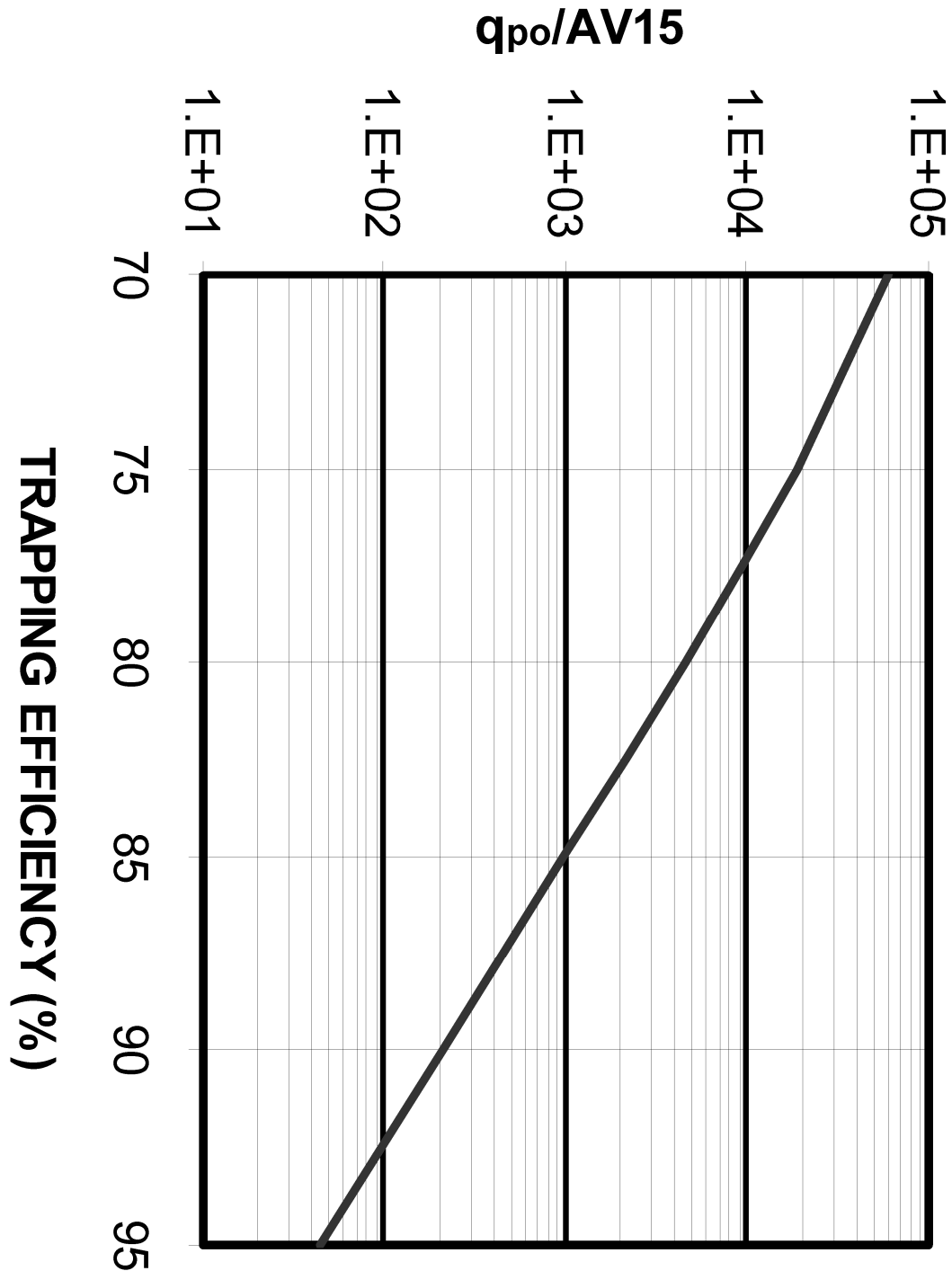

**DESIGN AID FOR ESTIMATING TRAPPING EFFICIENCY  
FOR SEDIMENT BASINS LOCATED IN LOW LYING  
AREAS AND/OR HAVING A HIGH WATER TABLE**

**FIGURE SV-1  
CHARACTERISTIC SETTLING VELOCITY AS A  
FUNCTION OF ERODED PARTICLE DIAMETER**

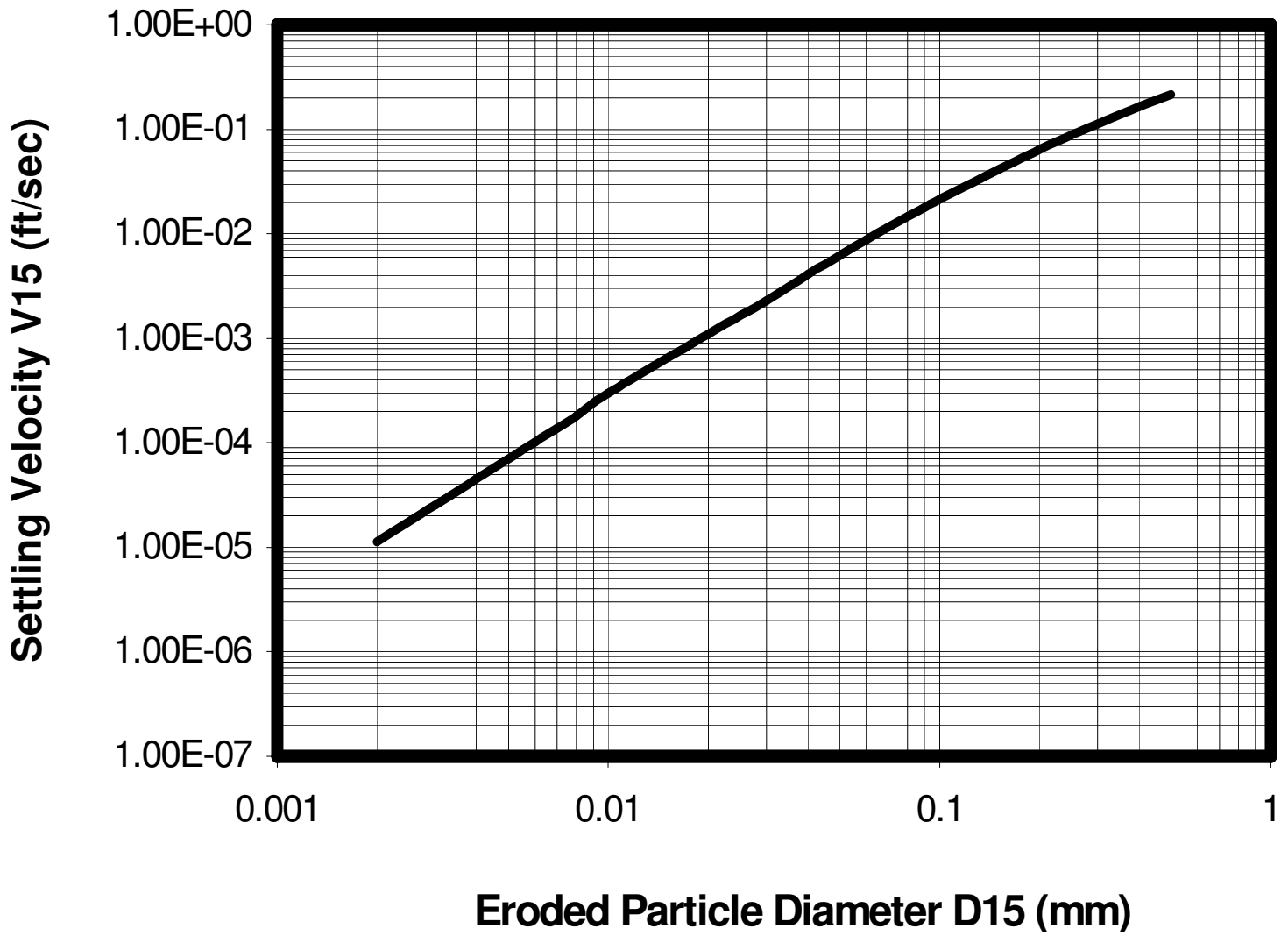

## **Reference 12**

ENG – Riprap Lined Plunge Pool for Cantilever Outlet, USDA SCS Design Note. No. 6, 2<sup>nd</sup> Ed. March 5, 1986.





United States  
Department of  
Agriculture

Soil  
Conservation  
Service

P.O. Box 2890  
Washington, D.C.  
20013

March 5, 1986

DESIGN NOTE NO. 6 (Second Edition)  
210-VI

SUBJECT: ENG - RIPRAP LINED PLUNGE POOL FOR CANTILEVER OUTLET

Purpose. To distribute Design Note No. 6 (Second Edition), "Riprap Lined Plunge Pool for Cantilever Outlet."

Effective Date. Effective when received.

Explanation. Design Note No. 6 was originally issued in 1969 and was based on research reported in 1967. This second edition was developed based on recently reported research by Fred W. Blaisdell of the Agricultural Research Service. The need for a revision of the original Design Note No. 6 has been identified by several reported situations of riprap being displaced from the plunge pool.

The Blaisdell developed mathematical model is in overall agreement with the experimental data. The purpose of this edition of the design note is to present Blaisdell's final design equations with modifications to facilitate construction and still meet the minimum design requirement.

Filing Instructions. Discard the 1969 edition of Design Note No. 6 and file this second edition with other design notes.

Distribution. The design note should be useful to professionals designing or reviewing the design of an energy dissipator at the downstream end of a conduit spillway. Initial distribution is shown on the reverse side. Additional copies may be obtained from Central Supply.

JOSEPH W. HAAS  
Deputy Chief for Technology

Enclosure

DIST: DN-6



)



Design Note No. 6 (Second Edition)\*

Subject: Riprap Lined Plunge Pool for Cantilever Outlet

INTRODUCTION

The energy in flow exiting from a spillway usually requires dissipation before being released to the outlet channel. For flow exiting from a conduit, when an open plunge pool is acceptable, an excavated riprap-lined hole at the downstream end of the conduit can be an economical energy dissipator. However, the size of plunge pool, location relative to the conduit outlet, and size of riprap must be properly designed for the plunge pool to operate successfully. Successful operation consists of negligible kinetic energy in the outflow, no erosion or loss of the plunge pool foundation soil due to the turbulence in the process of energy dissipation, and no displacement of the riprap.

Design Note No. 6, originally issued in 1969, was based on research reported in 1967. This second edition was developed based on recently reported research (Blaisdell and Anderson 1984). The need for a revision was identified by several reported situations of riprap being displaced from the plunge pool.

Fred W. Blaisdell, Research Hydraulic Engineer, of the Agricultural Research Service conducted experiments at the Saint Anthony Falls Hydraulic Laboratory of the University of Minnesota in Minneapolis to evaluate the scour at cantilevered pipe spillway outlets. The Blaisdell developed mathematical model indicates an overall agreement with the experimental data. The final equations for the design of plunge pool energy dissipators for cantilevered pipe spillways were presented at the ASCE Hydraulic Division Conference in Coeur d'Alene, Idaho, August, 1984. The purpose of this edition of the design note is to present the final design equations with modifications to facilitate the evaluation of plunge pool shape, length, width, depth, position in relation to the outlet end of the conduit, and plunge pool volumes. Figures 1 and 2 illustrate the plunge pool layout dimensions.

DISCHARGE PARAMETER

The plunge pool dimensions were developed using a discharge parameter. The parameter is based on the design discharge,  $Q$ , pipe diameter,  $D$ , and combined with the acceleration of gravity,  $g$ , resulting in a

\*Prepared by H. J. Goon, Design Unit, Engineering Division, Washington, D.C.

dimensionless parameter of  $\frac{Q}{\sqrt{gD^5}}$ . This is very convenient since  $Q$  and  $D$  are known prior to the plunge pool design.

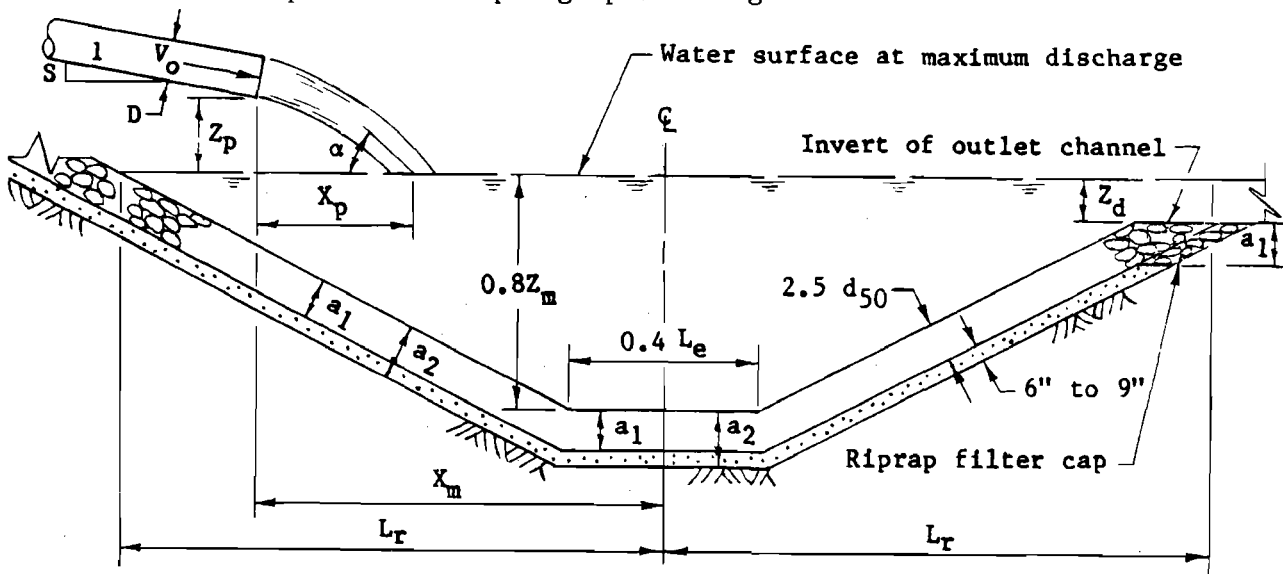

Figure 1 -- Plunge pool definition sketch

#### DISCHARGE JET TRAJECTORY

The plunge pool location is determined by the discharge jet trajectory. The location of the plunge pool centerline downstream from the discharge end of the pipe is dependent on the jet velocity and angle of impingement with the pool surface as well as the plunge pool depth.

The jet impingement velocity and angle of entry into the pool can be determined from the pipe exit slope, pipe discharge velocity, and height of pipe invert above the water surface. The height of pipe invert above the water surface,  $Z_p$ , should be measured from the tailwater elevation for the associated discharge used for the plunge pool design. The discharge should be the maximum prior to any secondary spillway flow. The pipe slope is  $\frac{S}{\sqrt{1 - S^2}}$ , where  $S$  is the sine of the angle whose

tangent is the slope of the pipe. The discharge velocity,  $V_o$ , is computed based on the design discharge and the conduit cross-sectional area. The path of the free falling jet is a parabola between the pipe exit and tailwater surface where the jet enters the water with the impingement velocity,  $V_p$ , and the slope,  $\tan \alpha$ . The horizontal distance,  $X_p$ , from the pipe exit to where the jet plunges into the tailwater with horizontal velocity,  $V_h$ , and vertical velocity,  $V_v$ , is given in Eq. 5; where

$$V_h = V_o \cos (\sin^{-1} S) \quad \text{Eq. 1}$$

$$V_v = \sqrt{(V_o S)^2 + 2g \left[ Z_p + \frac{D}{2} \cos (\sin^{-1} S) \right]} \quad \text{Eq. 2}$$

$$\tan \alpha = \frac{V_v}{V_h} \quad \text{Eq. 3}$$

$$V_p = \sqrt{V_h^2 + V_v^2} \quad \text{Eq. 4}$$

$$X_p = \frac{V_h}{g} (V_v - V_o S) \quad \text{Eq. 5}$$

#### PLUNGE POOL DEPTH

The depth of erosion created by the discharging jet can be controlled by the bed material size. The bed material is represented by its mean grain size,  $d_{50}$ , the size of which 50 percent by weight is finer in diameter. The research tests were run on noncohesive materials. Therefore, this design procedure is appropriate for soil and rock bed material that perform as single grain material in resisting erosion. The  $d_{50}$  size for riprap lining material may be varied to adjust the erosion depth. The plunge pool depth is computed using a densimetric Froude number,  $F_d$ , as follows:

$$F_d = \frac{V_p}{\sqrt{gd_{50} (\rho_s - \rho)/\rho}} \quad \text{Eq. 6}$$

where:  $\rho_s$  = Bed material or riprap particle density  
 $\rho$  = Water density

For  $\frac{Z_p}{D} < 1$ , the maximum eroded depth is computed by the equation

$$Z_m = 7.5 D \left[ 1 - e^{-0.6 (F_d - 2)} \right] \quad \text{Eq. 7a}$$

For  $\frac{Z_p}{D} > 1$ , the maximum eroded depth is computed by the equation

$$Z_m = 10.5 D \left[ 1 - e^{-0.35 (F_d - 2)} \right] \quad \text{Eq. 7b}$$

The effect of a horizontal ledge or a nonerodible layer on the shape of the plunge pool above the layer was tested and found to be a minimal.

The dimensions of the plunge pool are functions of  $\frac{Z_m}{D}$ . When the plunge pool dimensions are based on the value of  $Z_m$ , the designed contours above the ledge conform to the plunge pool shape. Therefore, it is acceptable to size and construct the plunge pool to 0.8 of the computed maximum depth,  $Z_m$ . However, the full value of the computed  $Z_m$ , as determined by equation 7a or 7b, must be used in subsequent equations 9, 10, and 11.

The  $d_{50}$  bed material size must be checked to assure that it is adequate to control shallow beach type erosion at the top edge of the plunge pool. High flow rates during research testing caused flow to circulate upstream along both sides of the plunge pool. When these circulating flows exceeded the bed material's critical tractive stress, beach erosion at the top edge of the plunge pool occurred. The check for adequate bed material size up to the tailwater elevation is by equation 8. The  $d_{50}$  size is adequate and beach erosion will not occur if

$$\frac{Q}{\sqrt{gD^5}} < \left[ 1.0 + 25 \frac{d_{50}}{D} \right] \quad \text{Eq. 8}$$

If the bed material  $d_{50}$  is not large enough, protection will need to be added. In the case of riprap, a larger particle gradation will be required.

#### LOCATION OF PLUNGE POOL

The horizontal distance,  $X_m$ , from the pipe exit to the center of the plunge pool, i.e., where maximum scour depth occurs is

$$X_m = \left[ X_p + \frac{Z_m}{\tan \alpha} \right] 1.15 e^{-0.15 \left[ Q/(gD^5) \right]^{1/2}} \quad \text{Eq. 9}$$

#### DIMENSION OF PLUNGE POOL

The plunge pool natural shape is an ellipse with the greater length parallel to the pipe flow. The minimum size based on laboratory tests is the result of flow turbulence, boundary tractive stresses and submerged angle of repose of granular material. The test material  $d_{50}$  sizes ranged from 0.5 to 8 mm. The minimum horizontal distance from the center of the plunge pool to the water surface contour at the upstream end of the pool is equal to  $L_e$ .

$$L_e = Z_m \left[ \frac{3}{2} + \frac{1}{3} \frac{Q}{\sqrt{gD^5}} \right] \quad \text{Eq. 10}$$

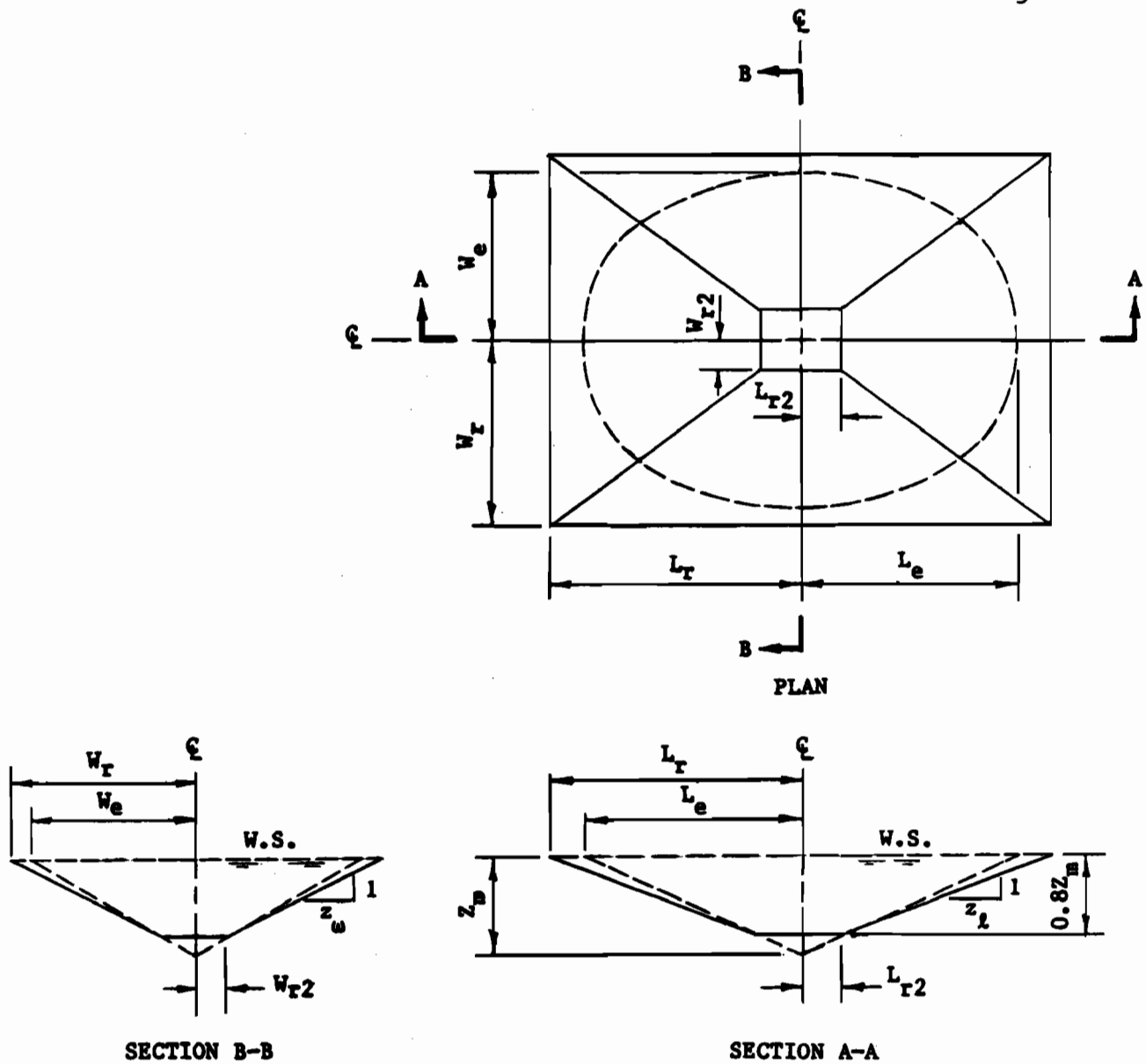

Figure 2 — Plunge Pool

Since the plunge pool shape is that of an ellipse, the distance from the center of the plunge pool to the water surface contour at the projected scour hole slope at the downstream end is also equal to the minimum  $L_e$ .

The minimum width of the plunge pool at the center of the pool is equal to  $2W_e$ .

$$W_e = z_m \left[ 1.5 + 0.15 \frac{Q}{\sqrt{gD^5}} \right] \quad \text{Eq. 11}$$

Once the minimum width, length, depth and the distance from the end of the pipe to the center of the plunge pool are determined for a given spillway layout and  $d_{50}$  particle size, the final design shape and dimensions can be established. It is suggested that a comparable rectangular shape with length equal to  $2L_e$  and width equal to  $2W_e$  be specified thus facilitating construction and still meeting the minimum design requirement. The dimensions of the rectangular base at the bottom of the plunge pool,  $0.8 Z_m$  below the water surface, are length,  $2L_{r2}$ , and width,  $2W_{r2}$  where;

$$2 L_{r2} = 0.4 L_e \quad \text{Eq. 12}$$

$$2 W_{r2} = 0.4 W_e \quad \text{Eq. 13}$$

It is recommended that the excavated side slopes of the plunge pool along the length,  $z_l$  and along the width,  $z_w$ , be adjusted to acceptable grades for layout and riprap placement purposes, e.g., 3 horizontal to 1 vertical. The final length and width of the plunge pool at the water surface are  $2L_r$  and  $2W_r$ , respectively. Where;

$$L_r = 0.8Z_m z_l + L_{r2} \quad \text{Eq. 14}$$

$$W_r = 0.8Z_m z_w + W_{r2} \quad \text{Eq. 15}$$

If  $L_r$  is less than  $X_m$ , the water surface contour at the upstream end of the pool is downstream from the end of the conduit. Therefore,  $L_r$  should be increased to equal to or greater than  $X_m$ .

#### PLUNGE POOL VOLUMES

The volume,  $V$ , in cu. yds. of the plunge pool and lining materials, such as riprap and granular filter, can be determined as frustums of pyramids. For convenience, the appropriate equation is listed below

$$V = \frac{1}{81} [A_1 + A_2 + \sqrt{A_1 A_2}] Z$$

where  $A_1$  is the plan rectangular area of the plunge pool at the invert elevation of the outlet channel,  $\text{ft}^2$   
 $A_2$  is the plan rectangular area at the bottom of the plunge pool at a distance  $Z$  below the invert elevation of the outlet channel,  $\text{ft}^2$



$Z$  is either equal to  $0.8Z_m - Z_d$ ,  $0.8Z_m - Z_d + a_1$ , or  $0.8Z_m - Z_d + a_2$  below the invert elevation of the outlet channel, ft.

$a_1$  is the thickness of the riprap lining, ft.

$a_2$  is the thickness of the riprap lining and granular filter material, ft.

$Z_d$  is the water depth above the invert elevation of the outlet channel, ft.

The volumes of riprap and filter material above the invert elevation of the outlet channel depend on the site topography.

#### PROCEDURE

The step procedure given below is in a form that can easily be programmed on either programmable calculators or microcomputers.

1. Compute  $\frac{Q}{\sqrt{gD^5}}$
2. Compute  $V_o = \frac{4Q}{\pi D^2}$
3. Compute  $V_h = V_o \cos(\sin^{-1} S)$  Eq. 1
- $V_v = \sqrt{(V_o S)^2 + 2g \left[ Z_p + \frac{D}{2} \cos(\sin^{-1} S) \right]}$  Eq. 2
- $\tan \alpha = \frac{V_v}{V_h}$  Eq. 3
- $V_p = \sqrt{V_h^2 + V_v^2}$  Eq. 4
- $X_p = \frac{V_h}{g} (V_v - V_o S)$  Eq. 5
4. Compute  $F_d = \frac{V_p}{\sqrt{gd_{50}(\rho_s - \rho) / \rho}}$  Eq. 6
5. Compute  $\frac{Z_p}{D}$  ; if  $< 1$ , Go to step 6a ; if  $> 1$ , Go to step 6b
- 6a. Compute  $Z_m = 7.5 D [1 - e^{-0.6 (F_d - 2)}]$ ; Go to step 7 Eq. 7a

6b. Compute  $Z_m = 10.5 D [1 - e^{-0.35 (F_d - 2)}]$  Eq. 7b

7. Compute  $1.0 + 25 \frac{d_{50}}{D}$  Eq. 8

8. If  $\frac{Q}{\sqrt{gD^5}} < 1.0 + 25 \frac{d_{50}}{D}$ , then go to step 9; otherwise, make design adjustments to increase  $d_{50}$  and return to step 4.

9. Compute  $X_m = [X_p + \frac{Z_m}{\tan \alpha}] 1.15 e^{-0.15 [Q/(gD^5)]^{1/2}}$  Eq. 9

10. Compute  $L_e = Z_m [ \frac{3}{2} + \frac{1}{3} \frac{Q}{\sqrt{gD^5}} ]$  Eq. 10

$$W_e = Z_m [ 1.5 + 0.15 \frac{Q}{\sqrt{gD^5}} ] \quad \text{Eq. 11}$$

11. Determine  $A_2$ , plan rectangular area of the plunge pool bottom at  $0.8Z_m$  below the water surface

$$L_{r2} = 0.2 L_e$$

$$W_{r2} = 0.2 W_e$$

$$A_2 = 4 L_{r2} W_{r2}$$

12. Check the side slopes of the plunge pool and adjust, if necessary to acceptable grades,  $z_\ell$  and  $z_\omega$ . The final length and width of the plunge pool at the water surface are  $2L_r$  and  $2W_r$ , respectively.

$$L_r = 0.8 Z_m z_\ell + L_{r2}$$

$$W_r = 0.8 Z_m z_\omega + W_{r2}$$

13. If  $L_r < X_m$ , increase side slope,  $z_\ell$ , so that  $L_r > X_m$

14. Determine  $A_1$ , plan rectangular area of the plunge pool at the invert elevation of the outlet channel

$$A_1 = 4 (L_r - z_\ell Z_d) (W_r - z_\omega Z_d)$$

## 15. Plunge Pool Volume:

The Volume between a horizontal plane at the invert elevation of the outlet channel and the exposed riprap surface is  $V_{a0}$ .

$$V_{a0} = \frac{1}{81} [A_1 + A_2 + \sqrt{A_1 A_2}] [0.8Z_m - Z_d], \text{ cu. yds.}$$

The volume between a horizontal plane at the invert elevation of the outlet channel and a surface at a thickness,  $a_1$ , below the exposed riprap surface is  $V_{a1}$ .

$$V_{a1} = \frac{1}{81} [A_{1a1} + A_{2a1} + \sqrt{A_{1a1} A_{2a1}}] [0.8Z_m - Z_d + a_1], \text{ cu. yds.}$$

$$\text{where } A_{1a1} = 4 [L_r - z_\ell Z_d + a_1 \sqrt{1 + z_\ell^2}] [W_r - z_\omega Z_d + a_1 \sqrt{1 + z_\omega^2}]$$

and

$$A_{2a1} = 4 [L_{r2} + a_1 (\sqrt{1 + z_\ell^2} - z_\ell)] [W_{r2} + a_1 (\sqrt{1 + z_\omega^2} - z_\omega)]$$

The volume of riprap at thickness,  $a_1$ , below a horizontal plane at the invert elevation of the outlet channel, exclusive of the volume of the riprap filter cap is  $V_{a1} - V_{a0}$ , cu. yds.

The volume between a horizontal plane at the invert elevation of the outlet channel and a surface at a thickness,  $a_2$ , below the exposed riprap surface is  $V_{a2}$

$$V_{a2} = \frac{1}{81} [A_{1a2} + A_{2a2} + \sqrt{A_{1a2} A_{2a2}}] [0.8Z_m - Z_d + a_2], \text{ cu. yds.}$$

$$\text{where } A_{1a2} = 4 [L_r - z_\ell Z_d + a_2 \sqrt{1 + z_\ell^2}] [W_r - z_\omega Z_d + a_2 \sqrt{1 + z_\omega^2}]$$

and

$$A_{2a2} = 4 [L_{r2} + a_2 (\sqrt{1 + z_\ell^2} - z_\ell)] [W_{r2} + a_2 (\sqrt{1 + z_\omega^2} - z_\omega)]$$

The volume of filter material of thickness,  $a_2 - a_1$ , below a horizontal plane at the invert elevation of the outlet channel, including the volume of the riprap filter cap, is equal to  $V_{a2} - V_{a1}$ , cu. yds.

## EXAMPLE

## Given:

Invert elevation at outlet end of conduit = 102.5  
 Invert elevation of outlet channel = 100.0  
 Elevation of tailwater for maximum conduit discharge = 101.5  
 $Q = 147$  cfs,  $D = 2.5$  ft.,  $S = 0$   
 Riprap size,  $d_{50} = 1.0$  ft.,  $\rho_s = 2.64$   
 Thickness of filter material bed = 0.75 ft.

## Determine:

- I. Plunge pool position with respect to outlet end of conduit
- II. Plunge pool depth, length, and width
- III. Plunge pool volumes below the invert elevation of outlet channel

## Solution:

$$1. \quad \frac{Q}{\sqrt{gD^5}} = \frac{147}{\sqrt{32.16(2.5)^5}} = 2.62$$

$$2. \quad v_o = \frac{4Q}{\pi D^2} = \frac{4(147)}{3.14(2.5)^2} = 30 \text{ ft/sec}$$

$$3. \quad v_h = v_o \cos(\sin^{-1} S) = 30 \text{ ft/sec}$$

$$v_v = \left[ (v_o S)^2 + 2g\left(z_p + \frac{D}{2} \cos(\sin^{-1} S)\right) \right]^{1/2} = \left[ 0 + 64.32 \left(1.0 + \frac{2.5}{2}\right) \right]^{1/2}$$

$$= 12.0 \text{ ft/sec}$$

$$\tan \alpha = \frac{v_v}{v_h} = \frac{12.0}{30} = 0.40$$

$$v_p = \sqrt{v_h^2 + v_v^2} = \sqrt{(30)^2 + (12.0)^2} = 32.3 \text{ ft/sec}$$

$$x_p = \frac{v_h}{g} (v_v - v_o S) = \frac{30}{32.16} (12.0) = 11.2 \text{ ft}$$

$$4. \quad F_d = \frac{v_p}{\sqrt{gd_{50} (\rho_s - \rho) / \rho}} = \frac{32.3}{\sqrt{32.16(1) (2.64 - 1) / 1}} = 4.45$$

$$5. \quad \frac{z_p}{D} = \frac{1}{2.5} = 0.4 < 1, \text{ therefore use Equation 6a}$$

$$6. \quad z_m = 7.5D [1 - e^{-0.6 (F_d - 2)}] = 7.5 (2.5) [1 - e^{-1.47}] = 14.4 \text{ ft}$$

$$7. \quad 1.0 + 25 \frac{d_{50}}{D} = 1.0 + 25 \frac{1}{2.5} = 11$$

$$8. \quad \frac{Q}{\sqrt{gD^5}} < [1.0 + 25 \frac{d_{50}}{D}]; \text{ therefore riprap size is adequate to prevent significant shallow erosion enlargement at water surface elevation.}$$

9. Plunge pool position from outlet end of pipe to center of pool,  $X_m$

$$X_m = [X_p + \frac{Z_m}{\tan \alpha}] 1.15 e^{-0.15 (Q/\sqrt{gD^5})}$$

$$X_m = [11.2 + \frac{14.4}{0.40}] 1.15 e^{-0.15(2.62)} = 36.6 \text{ ft}$$

10. Plunge Pool Dimensions

$$\text{depth at center} = 0.8 Z_m = 0.8 (14.4) = 11.5 \text{ ft}$$

$$L_e = Z_m \left[ \frac{3}{2} + \frac{1}{3} \frac{Q}{\sqrt{gD^5}} \right] = 14.4 \left[ \frac{3}{2} + \frac{2.62}{3} \right] = 34.2 \text{ ft}$$

$$W_e = Z_m \left[ 1.5 + 0.15 \frac{Q}{\sqrt{gD^5}} \right] = 14.4 [1.5 + 0.15 (2.62)] = 27.3 \text{ ft}$$

$$11. \quad L_{r2} = 0.2 L_e = 0.2(34.2) = 6.8 \text{ ft.}$$

$$W_{r2} = 0.2 W_e = 0.2(27.3) = 5.5 \text{ ft.}$$

$$A_2 = 4 L_{r2} W_{r2} = 4(6.8)(5.5) = 150 \text{ ft}^2$$

$$12. \quad z_\ell = \frac{L_e - L_{r2}}{0.8Z_m} = \frac{34.2 - 6.8}{11.5} = 2.4; \text{ Adjust } z_\ell \text{ to } 3.0$$

$$\therefore L_r = 0.8Z_m z_\ell + L_{r2} = 11.5 (3.0) + 6.8 = 41.3 \text{ ft.}$$

$$z_\omega = \frac{W_e - W_{r2}}{0.8Z_m} = \frac{27.3 - 5.5}{11.5} = 1.9; \text{ Adjust } z_\omega \text{ to } 2.0$$

$$\therefore W_r = 0.8Z_m z_\omega + W_{r2} = 11.5 (2.0) + 5.5 = 28.5 \text{ ft.}$$

$$13. \quad L_r = 41.3 > X_m = 36.6 \quad \text{O.K.}$$

$$14. \quad A_1 = 4 (L_r - z_\ell Z_d) (W_r - z_\omega Z_d) = 4 [41.3 - 3(1.5)] [28.5 - 2(1.5)] \\ = 3754 \text{ ft}^2$$

$$15. \quad V_{ao} = \frac{1}{81} [A_1 + A_2 + \sqrt{A_1 A_2}] [0.8Z_m - Z_d] \\ = \frac{1}{81} [3754 + 150 + \sqrt{3754 \times 150}] [11.5 - 1.5] = 574 \text{ cu. yds.}$$

$$\begin{aligned}
 A_{1a1} &= 4 [L_r - z_l z_d + a_1 \sqrt{1 + z_l^2}] [W_r - z_w z_d + a_1 \sqrt{1 + z_w^2}] \\
 &= 4 [41.3 - 3(1.5) + 2.5 \sqrt{1 + 3^2}] [28.5 - 2(1.5) + 2.5 \sqrt{1 + 2^2}] \\
 &= 5560 \text{ ft}^2
 \end{aligned}$$

$$\begin{aligned}
 A_{2a1} &= 4 [L_{r2} + a_1 (\sqrt{1 + z_l^2} - z_l)] [W_{r2} + a_1 (\sqrt{1 + \frac{z_w^2}{2}} - z_w)] \\
 &= 4 [6.8 + 2.5 (\sqrt{1 + 3^2} - 3)] [5.5 + 2.5 (\sqrt{1 + 2^2} - 2)] = 176 \text{ ft}^2
 \end{aligned}$$

$$\begin{aligned}
 V_{a1} &= \frac{1}{81} [A_{1a1} + A_{2a1} + \sqrt{A_{1a1} A_{2a1}}] [0.8z_m - z_d + a_1] \\
 &= \frac{1}{81} [5560 + 176 + \sqrt{5560 \times 176}] [11.5 - 1.5 + 2.5] = 1038 \text{ cu. yds.}
 \end{aligned}$$

$$\text{Volume of riprap} = V_{a1} - V_{a0} = 1038 - 574 = 464 \text{ cu. yds.}$$

$$A_{1a2} = 4 [41.3 - 4.5 + 3.25 \sqrt{10}] [28.5 - 3 + 3.25 \sqrt{5}] = 6170 \text{ ft}^2$$

$$A_{2a2} = 4 [6.8 + 3.25 (\sqrt{10} - 3)] [5.5 + 3.25 (\sqrt{5} - 2)] = 184 \text{ ft}^2$$

$$V_{a2} = \frac{1}{81} [6170 + 184 + \sqrt{6170 \times 184}] [11.5 - 1.5 + 3.25] = 1214 \text{ cu. yds.}$$

$$\text{Volume of filter} = V_{a2} - V_{a1} = 1214 - 1038 = 176 \text{ cu. yds.}$$

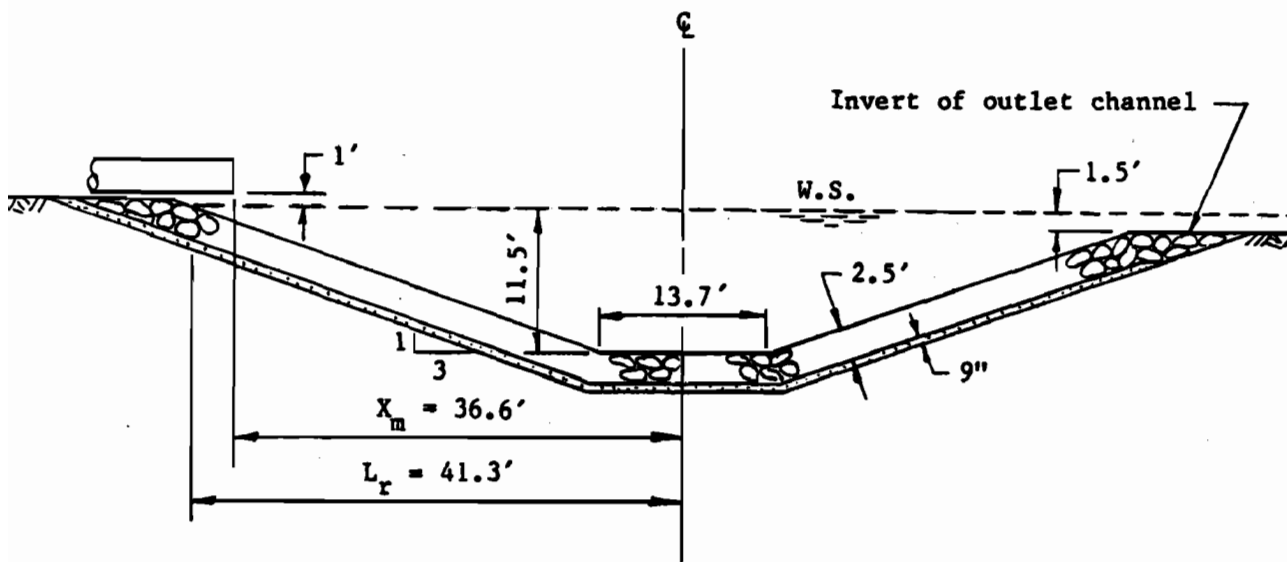

## NOMENCLATURE

$a_1$	≡	Thickness of riprap, ft
$a_2$	≡	Thickness of riprap and filter material, ft
$A_1$	≡	Plan rectangular area of the plunge pool at the invert elevation of the outlet channel, ft <sup>2</sup>
$A_2$	≡	Plan rectangular area at the bottom of the plunge pool at a distance Z below the invert elevation of the outlet channel, ft <sup>2</sup> .
$d_{50}$	≡	Size of rock in riprap of which 50 percent by weight is finer, ft
D	≡	Cantilever outlet pipe diameter, ft
e	≡	Base of natural logarithms
$F_d$	≡	Densimetric Froude number
g	≡	Acceleration of gravity, ft/sec <sup>2</sup>
$L_e$	≡	Minimum horizontal distance from the center of the pool to the water surface contour at the upstream or downstream end of an elliptical-shape plunge pool, ft
$L_r$	≡	Adjusted horizontal distance from the center of the pool to the water surface contour at the upstream or downstream end of the rectangular-shape plunge pool, ft
$L_{r2}$	≡	One-half the length of the bottom of a rectangular-shape plunge pool, ft
Q	≡	Design discharge, cfs
S	≡	Sine of the angle whose tangent is the slope of the pipe
$V_{a0}$	≡	Volume of the plunge pool between the invert elevation of the outlet channel and the exposed riprap surface, cu. yds.
$V_{a1}$	≡	Volume of the plunge pool between the invert elevation of the outlet channel and a surface at a thickness, $a_1$ , below the exposed riprap surface, cu. yds.
$V_{a2}$	≡	Volume of the plunge pool between the invert elevation of the outlet channel and a surface at a thickness, $a_2$ , below the exposed riprap surface, cu. yds.

$V_h$	≡	Horizontal component of the jet impingement velocity, $V_p$ , ft/sec
$V_o$	≡	Velocity in the pipe corresponding to the design discharge, $Q$ , ft/sec
$V_p$	≡	Velocity where the jet plunges into the water surface, ft/sec
$V_v$	≡	Vertical component of the jet impingement velocity, $V_p$ , ft/sec
$W_e$	≡	One-half the minimum width at the center of the elliptical- shape plunge pool at the water surface elevation, ft
$W_r$	≡	One-half the adjusted width at the center of the rectangular- shape plunge pool at the water surface elevation, ft
$W_{r2}$	≡	One-half the width of the bottom of a rectangular plunge pool, ft
$X_m$	≡	Horizontal distance from the pipe exit to the center of the plunge pool, ft
$X_p$	≡	Horizontal distance from the pipe exit to the center of the jet plunging into the water surface, ft
$z_l$	≡	Side slope ratio of the upstream or downstream slope of the rectangular-shape plunge pool
$Z_w$	≡	Side slope ratio of the side slopes of the rectangular- shape plunge pool
$Z_d$	≡	Water depth above the invert elevation of the outlet channel, ft
$Z_m$	≡	Maximum computed depth of the plunge pool, ft
$Z_p$	≡	Vertical distance from the tailwater surface to the cantilever pipe invert, ft
$\rho$	≡	Water density
$\rho_s$	≡	Bed material or riprap particle density
$\alpha$	≡	Jet impingement angle where the jet plunges into the water surface



REFERENCES

Blaisdell, F. W., and Anderson, C. L. 1984. Pipe spillway plunge pool design equations. Proceedings of the conference - water for resource development, Hydraulics Division, ASCE, Coeur d'Alene, Idaho.

Anderson, C. L. and Blaisdell, F. W. 1982. Plunge pool energy dissipator for pipe spillways, Proceedings of the conference - applying research to hydraulic practice, ASCE, Jackson, Mississippi, p. 289-297.

Blaisdell, F. W., Anderson, C. L., and Hebaus, G. G. 1981. Ultimate dimensions of local scour. Journal of the Hydraulics Division, ASCE, Vol. 107, No. HY3, Proc. Paper 16144, p. 327-337.

(210-VI-DN-6, Second Ed., January 1986)

## **Reference 13**

Riprap Lined Plunge Pool for Cantilever Outlet, NRCS Plunge Pool Sheets, March 2021.

RIPRAP LINED PLUNGE POOL FOR CANTILEVER OUTLET (Version 8.99)  
 (Reference Design Note No. 6 (Second Edition), Jan. 23, 1986)

JOB:	Luck Stone PT-SB-1 Plunge Pool	Date:	3/9/2021
DESIGNER:	JCC	Date:	3/9/2021
CHECKER:	AEW	Date:	3/9/2021

INPUT DATA:

Conduit Diameter	D =	2.00	ft
Conduit Discharge:	Q =	6.41	cfs
Conduit Slope at Outlet:	S =	0.01	ft/ft
Conduit Outlet Invert Elevation:	EI, CO =	556.00	ft
Tailwater Elevation:	EI, TW =	556.00	ft
Outlet Channel Invert Elevation:	EI, CH =	556.00	ft

Water Density:	RHO =	1.00	
Bed/Riprap Particle Density: (Default 2.64)	RHOS =	2.64	
D, 50 Riprap Size:	RS =	0.25	ft
Riprap Thickness: (2.5*D, 50 recommended)	RT =	0.63	ft
Bedding Thickness: (6 inch min. rec.) ( <u>Enter 0 for geotextile</u> )	BT =	0.50	ft
Side Slope Ratio:	Zw =	2.00	ft/ft
Upstream End Slope Ratio:	Zlu =	3.00	ft/ft
Downstream End Slope Ratio:	Zld =	3.00	ft/ft
Combined End Slope Ratio:	Z1 =	3.00	ft/ft

OUTPUT---POOL LOCATION AND DIMENSIONS:

Vert. Dist. from Tailwater to Conduit Invert:	Zp =	0.00	ft
Submergence Check: (If Zp < 0 , Use Zp = 0)	Use Zp =	0.00	ft
Beaching Check: $[Q/(gD^{.5})^{0.5} \leq (1.0+25*D,50/D)]$		O.K.	
**Beaching Controlled**			
Distance from Conduit Exit to C/L Pool:	Xm =	1.22	ft
Pool depth at C/L Below Conduit Invert:	Zp+0.8Zm =	1.85	ft
Pool Bottom Elev:	EI,PB =	554.15	ft
Pool Bottom Length:	2Lr2 =	1.45	ft
Pool Bottom Width:	2Wr2 =	1.41	ft
Upstream Pool Length at Tailwater Elev.:	Lru =	6.27	ft
Downstream Pool Length at Tailwater Elev.:	Lrd =	6.27	ft
Pool Width at Tailwater Elev.:	2Wr =	8.81	ft
Check Side Slope Ratio: (Wr>=We)		O.K.	
**Side Slope Ratio Zw O.K.**			
Check Min. End Slope Ratio: (Lru & Lrd >= Le)		O.K.	
**End Slope Ratios O.K.**			
Check Upstream Length: (Lru >= Xm)		O.K.	
**End Slope Ratio Zlu O.K.**			
Pool Bottom Elev. at Bottom of Riprap:	EI, BR =	553.53	ft
Pool Bottom Elev. at Bottom of Bedding:	EI, BB =	553.03	ft

**OUTPUT---VOLUMES BELOW WATER SURFACE ELEVATION:**

Volume of Excavation (measured from bottom surface of bedding):	V,pbs =	11.2	cu yd
Volume of Rock Riprap:	V,rs =	3.7	cu yd
Volume of Bedding:	V,bs =	4.5	cu yd

RIPRAP LINED PLUNGE POOL FOR CANTILEVER OUTLET  
 Reference Design Note No. 6 (Second Edition), Jan. 23, 1986

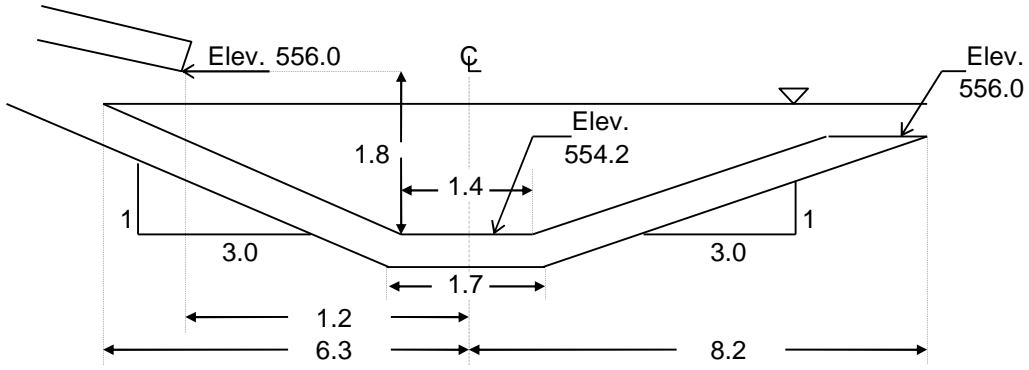

SECTION A-A

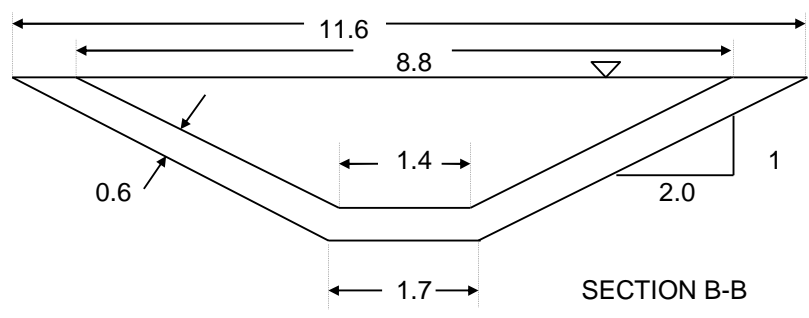

SECTION B-B

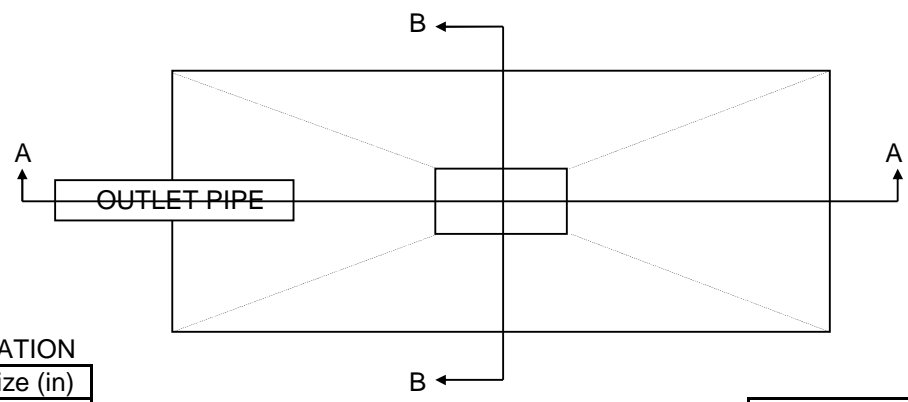

ROCK GRADATION

% Passing	Size (in)
100	6
60-85	4.5
25-50	3
5-20	1.5
0-5	0.6

Luck Stone PT-SB-1 Plunge Pool  
 LANDOWNER  
 DESIGNER: JCC  
 SHEET   1   OF   9

RIPRAP LINED PLUNGE POOL FOR CANTILEVER OUTLET (Version 8.99)  
 (Reference Design Note No. 6 (Second Edition), Jan. 23, 1986)

JOB:	Luck Stone W-SB-1 Plunge Pool	Date:	3/9/2021
DESIGNER:	JCC	Date:	3/9/2021
CHECKER:	AEW	Date:	3/9/2021

INPUT DATA:

Conduit Diameter	D =	2.00	ft
Conduit Discharge:	Q =	4.93	cfs
Conduit Slope at Outlet:	S =	0.01	ft/ft
Conduit Outlet Invert Elevation:	El, CO =	499.00	ft
Tailwater Elevation:	El, TW =	499.00	ft
Outlet Channel Invert Elevation:	El, CH =	499.00	ft

Water Density:	RHO =	1.00	
Bed/Riprap Particle Density: (Default 2.64)	RHOS =	2.64	
D, 50 Riprap Size:	RS =	0.25	ft
Riprap Thickness: (2.5*D, 50 recommended)	RT =	0.63	ft
Bedding Thickness: (6 inch min. rec.) ( <u>Enter 0 for geotextile</u> )	BT =	0.50	ft
Side Slope Ratio:	Zw =	2.00	ft/ft
Upstream End Slope Ratio:	Zlu =	3.00	ft/ft
Downstream End Slope Ratio:	Zld =	3.00	ft/ft
Combined End Slope Ratio:	Z1 =	3.00	ft/ft

OUTPUT---POOL LOCATION AND DIMENSIONS:

Vert. Dist. from Tailwater to Conduit Invert:	Zp =	0.00	ft
Submergence Check: (If Zp < 0 , Use Zp = 0)	Use Zp =	0.00	ft
Beaching Check: $[Q/(gD^{.5})^{0.5} \leq (1.0+25 \cdot D, 50/D)]$		O.K.	
**Beaching Controlled**			
Distance from Conduit Exit to C/L Pool:	Xm =	0.90	ft
Pool depth at C/L Below Conduit Invert:	Zp+0.8Zm =	1.67	ft
Pool Bottom Elev:	El,PB =	497.33	ft
Pool Bottom Length:	2Lr2 =	1.30	ft
Pool Bottom Width:	2Wr2 =	1.27	ft
Upstream Pool Length at Tailwater Elev.:	Lru =	5.67	ft
Downstream Pool Length at Tailwater Elev.:	Lrd =	5.67	ft
Pool Width at Tailwater Elev.:	2Wr =	7.97	ft
Check Side Slope Ratio: (Wr>=We)		O.K.	
**Side Slope Ratio Zw O.K.**			
Check Min. End Slope Ratio: (Lru & Lrd >= Le)		O.K.	
**End Slope Ratios O.K.**			
Check Upstream Length: (Lru >= Xm)		O.K.	
**End Slope Ratio Zlu O.K.**			
Pool Bottom Elev. at Bottom of Riprap:	El, BR =	496.70	ft
Pool Bottom Elev. at Bottom of Bedding:	El, BB =	496.20	ft

**OUTPUT---VOLUMES BELOW WATER SURFACE ELEVATION:**

Volume of Excavation (measured from bottom surface of bedding):	V,pbs =	9.2	cu yd
Volume of Rock Riprap:	V,rs =	3.1	cu yd
Volume of Bedding:	V,bs =	3.9	cu yd

RIPRAP LINED PLUNGE POOL FOR CANTILEVER OUTLET  
 Reference Design Note No. 6 (Second Edition), Jan. 23, 1986

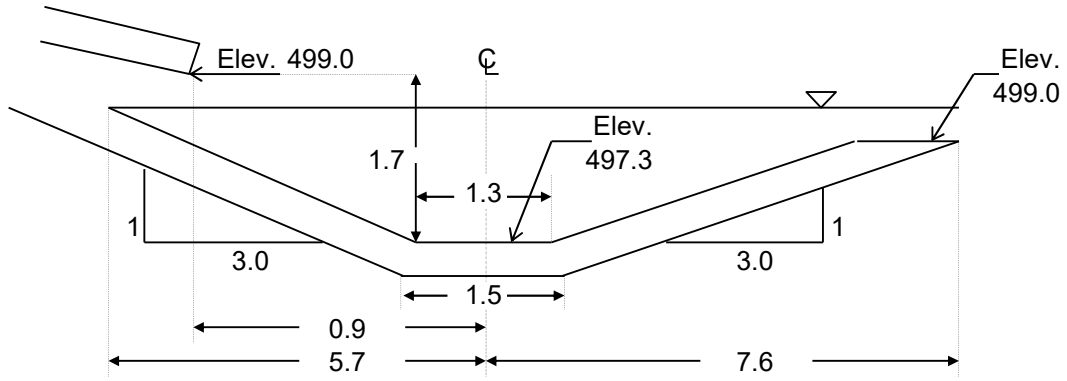

SECTION A-A

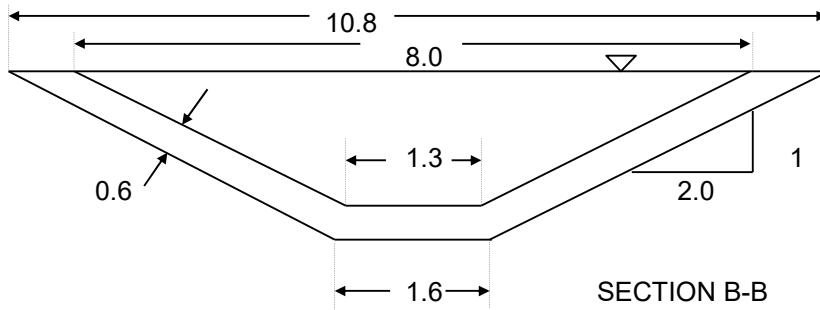

SECTION B-B

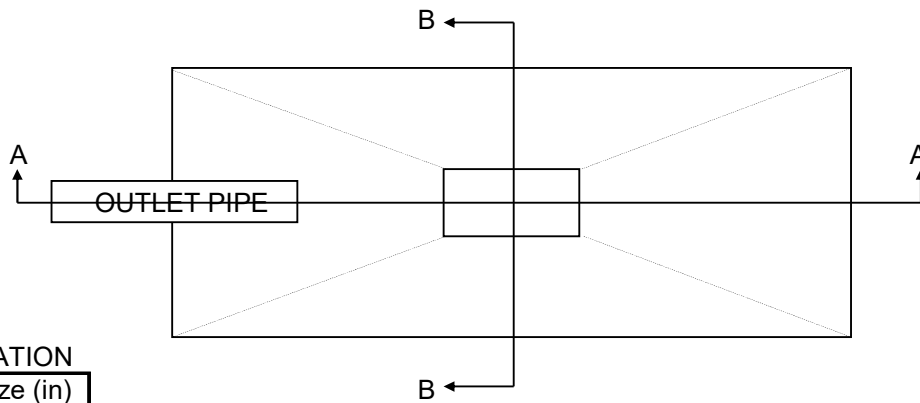

ROCK GRADATION

% Passing	Size (in)
100	6
60-85	4.5
25-50	3
5-20	1.5
0-5	0.6

Luck Stone W-SB-1 Plunge Pool  
 LANDOWNER

DESIGNER: JCC  
 SHEET 2 OF 9

RIPRAP LINED PLUNGE POOL FOR CANTILEVER OUTLET (Version 8.99)  
 (Reference Design Note No. 6 (Second Edition), Jan. 23, 1986)

JOB:	Luck Stone P-SB-1 Plunge Pool	Date:	3/10/2021
DESIGNER:	JCC	Date:	3/10/2021
CHECKER:	AEW	Date:	3/10/2021

INPUT DATA:

Conduit Diameter	D =	2.00	ft
Conduit Discharge:	Q =	11.54	cfs
Conduit Slope at Outlet:	S =	0.01	ft/ft
Conduit Outlet Invert Elevation:	EI, CO =	449.00	ft
Tailwater Elevation:	EI, TW =	449.00	ft
Outlet Channel Invert Elevation:	EI, CH =	449.00	ft

Water Density:	RHO =	1.00	
Bed/Riprap Particle Density: (Default 2.64)	RHOS =	2.64	
D, 50 Riprap Size:	RS =	0.25	ft
Riprap Thickness: (2.5*D, 50 recommended)	RT =	0.63	ft
Bedding Thickness: (6 inch min. rec.) ( <u>Enter 0 for geotextile</u> )	BT =	0.50	ft
Side Slope Ratio:	Zw =	2.00	ft/ft
Upstream End Slope Ratio:	Zlu =	3.00	ft/ft
Downstream End Slope Ratio:	Zld =	3.00	ft/ft
Combined End Slope Ratio:	Z1 =	3.00	ft/ft

OUTPUT---POOL LOCATION AND DIMENSIONS:

Vert. Dist. from Tailwater to Conduit Invert:	Zp =	0.00	ft
Submergence Check: (If Zp < 0 , Use Zp = 0)	Use Zp =	0.00	ft
Beaching Check: $[Q/(gD^5)^{0.5} \leq (1.0+25*D,50/D)]$		O.K.	
**Beaching Controlled**			
Distance from Conduit Exit to C/L Pool:	Xm =	2.69	ft
Pool depth at C/L Below Conduit Invert:	Zp+0.8Zm =	2.72	ft
Pool Bottom Elev:	EI,PB =	446.28	ft
Pool Bottom Length:	2Lr2 =	2.21	ft
Pool Bottom Width:	2Wr2 =	2.12	ft
Upstream Pool Length at Tailwater Elev.:	Lru =	9.27	ft
Downstream Pool Length at Tailwater Elev.:	Lrd =	9.27	ft
Pool Width at Tailwater Elev.:	2Wr =	13.01	ft
Check Side Slope Ratio: (Wr>=We)		O.K.	
**Side Slope Ratio Zw O.K.**			
Check Min. End Slope Ratio: (Lru & Lrd >= Le)		O.K.	
**End Slope Ratios O.K.**			
Check Upstream Length: (Lru >= Xm)		O.K.	
**End Slope Ratio Zlu O.K.**			
Pool Bottom Elev. at Bottom of Riprap:	EI, BR =	445.65	ft
Pool Bottom Elev. at Bottom of Bedding:	EI, BB =	445.15	ft

**OUTPUT---VOLUMES BELOW WATER SURFACE ELEVATION:**

Volume of Excavation (measured from bottom surface of bedding):	V,pbs =	24.8	cu yd
Volume of Rock Riprap:	V,rs =	7.4	cu yd
Volume of Bedding:	V,bs =	8.0	cu yd

RIPRAP LINED PLUNGE POOL FOR CANTILEVER OUTLET  
 Reference Design Note No. 6 (Second Edition), Jan. 23, 1986

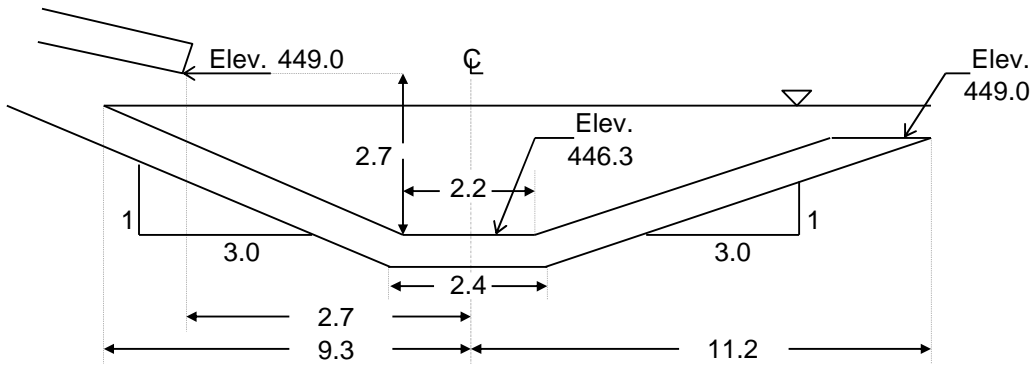

SECTION A-A

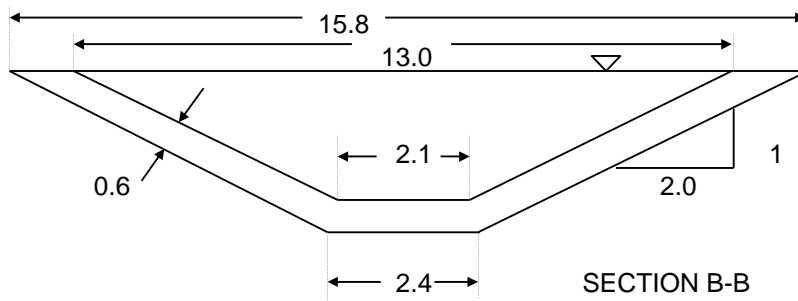

SECTION B-B

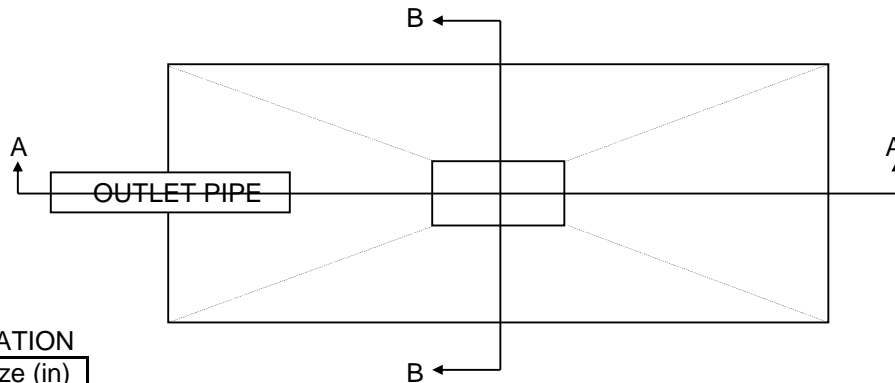

ROCK GRADATION

% Passing	Size (in)
100	6
60-85	4.5
25-50	3
5-20	1.5
0-5	0.6

Luck Stone P-SB-1 Plunge Pool  
 LANDOWNER

DESIGNER: JCC  
 SHEET 3 OF 9



RIPRAP LINED PLUNGE POOL FOR CANTILEVER OUTLET (Version 8.99)  
 (Reference Design Note No. 6 (Second Edition), Jan. 23, 1986)

JOB:	Luck Stone P-SB-2 Plunge Pool	Date:	3/9/2021
DESIGNER:	JCC	Date:	3/9/2021
CHECKER:	AEW	Date:	3/9/2021

INPUT DATA:

Conduit Diameter	D =	2.00	ft
Conduit Discharge:	Q =	5.03	cfs
Conduit Slope at Outlet:	S =	0.01	ft/ft
Conduit Outlet Invert Elevation:	EI, CO =	480.00	ft
Tailwater Elevation:	EI, TW =	480.00	ft
Outlet Channel Invert Elevation:	EI, CH =	480.00	ft

Water Density:	RHO =	1.00	
Bed/Riprap Particle Density: (Default 2.64)	RHOS =	2.64	
D, 50 Riprap Size:	RS =	0.25	ft
Riprap Thickness: (2.5*D, 50 recommended)	RT =	0.63	ft
Bedding Thickness: (6 inch min. rec.) ( <u>Enter 0 for geotextile</u> )	BT =	0.50	ft
Side Slope Ratio:	Zw =	2.00	ft/ft
Upstream End Slope Ratio:	Zlu =	3.00	ft/ft
Downstream End Slope Ratio:	Zld =	3.00	ft/ft
Combined End Slope Ratio:	Z1 =	3.00	ft/ft

OUTPUT---POOL LOCATION AND DIMENSIONS:

Vert. Dist. from Tailwater to Conduit Invert:	Zp =	0.00	ft
Submergence Check: (If Zp < 0 , Use Zp = 0)	Use Zp =	0.00	ft
Beaching Check: $[Q/(gD^{.5})^{0.5} \leq (1.0+25 \cdot D, 50/D)]$		O.K.	
**Beaching Controlled**			
Distance from Conduit Exit to C/L Pool:	Xm =	0.92	ft
Pool depth at C/L Below Conduit Invert:	Zp+0.8Zm =	1.68	ft
Pool Bottom Elev:	EI, PB =	478.32	ft
Pool Bottom Length:	2Lr2 =	1.31	ft
Pool Bottom Width:	2Wr2 =	1.28	ft
Upstream Pool Length at Tailwater Elev.:	Lru =	5.71	ft
Downstream Pool Length at Tailwater Elev.:	Lrd =	5.71	ft
Pool Width at Tailwater Elev.:	2Wr =	8.02	ft
Check Side Slope Ratio: (Wr >= We)		O.K.	
**Side Slope Ratio Zw O.K.**			
Check Min. End Slope Ratio: (Lru & Lrd >= Le)		O.K.	
**End Slope Ratios O.K.**			
Check Upstream Length: (Lru >= Xm)		O.K.	
**End Slope Ratio Zlu O.K.**			
Pool Bottom Elev. at Bottom of Riprap:	EI, BR =	477.69	ft
Pool Bottom Elev. at Bottom of Bedding:	EI, BB =	477.19	ft

**OUTPUT---VOLUMES BELOW WATER SURFACE ELEVATION:**

Volume of Excavation (measured from bottom surface of bedding):	V,pbs =	9.4	cu yd
Volume of Rock Riprap:	V,rs =	3.2	cu yd
Volume of Bedding:	V,bs =	4.0	cu yd

RIPRAP LINED PLUNGE POOL FOR CANTILEVER OUTLET  
 Reference Design Note No. 6 (Second Edition), Jan. 23, 1986

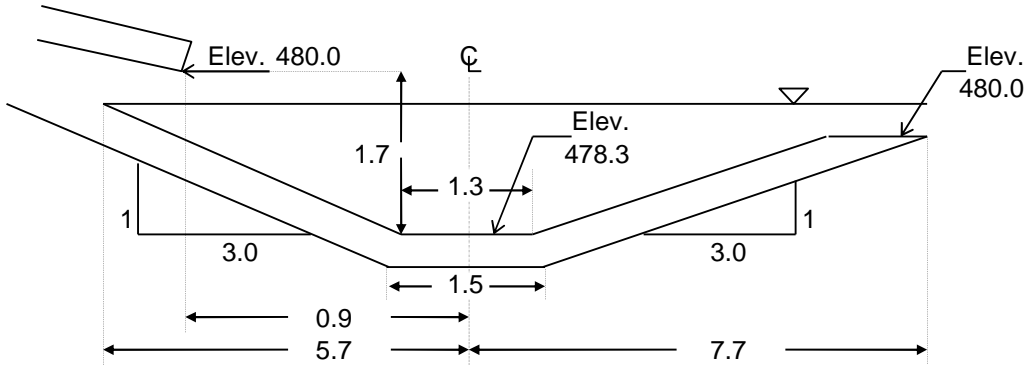

SECTION A-A

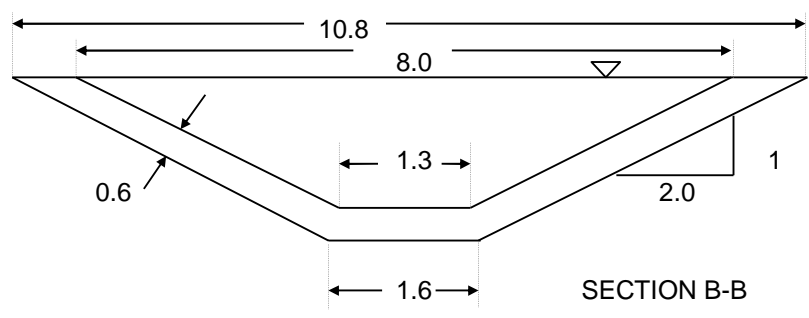

SECTION B-B

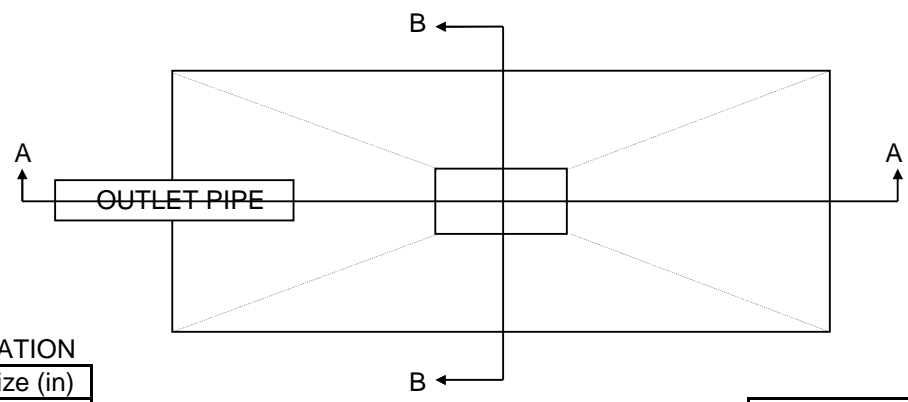

ROCK GRADATION

% Passing	Size (in)
100	6
60-85	4.5
25-50	3
5-20	1.5
0-5	0.6

Luck Stone P-SB-2 Plunge Pool  
 LANDOWNER

DESIGNER: JCC  
 SHEET 4 OF 9

RIPRAP LINED PLUNGE POOL FOR CANTILEVER OUTLET (Version 8.99)  
 (Reference Design Note No. 6 (Second Edition), Jan. 23, 1986)

JOB:	Luck Stone P-SB-3 Plunge Pool	Date:	3/18/2021
DESIGNER:	JCC	Date:	3/18/2021
CHECKER:	AEW	Date:	3/18/2021

INPUT DATA:

Conduit Diameter	D =	2.00	ft
Conduit Discharge:	Q =	6.76	cfs
Conduit Slope at Outlet:	S =	0.01	ft/ft
Conduit Outlet Invert Elevation:	EI, CO =	489.00	ft
Tailwater Elevation:	EI, TW =	489.00	ft
Outlet Channel Invert Elevation:	EI, CH =	489.00	ft

Water Density:	RHO =	1.00	
Bed/Riprap Particle Density: (Default 2.64)	RHOS =	2.64	
D, 50 Riprap Size:	RS =	0.25	ft
Riprap Thickness: (2.5*D, 50 recommended)	RT =	0.63	ft
Bedding Thickness: (6 inch min. rec.) ( <u>Enter 0 for geotextile</u> )	BT =	0.50	ft
Side Slope Ratio:	Zw =	2.00	ft/ft
Upstream End Slope Ratio:	Zlu =	3.00	ft/ft
Downstream End Slope Ratio:	Zld =	3.00	ft/ft
Combined End Slope Ratio:	Z1 =	3.00	ft/ft

OUTPUT---POOL LOCATION AND DIMENSIONS:

Vert. Dist. from Tailwater to Conduit Invert:	Zp =	0.00	ft
Submergence Check: (If Zp < 0 , Use Zp = 0)	Use Zp =	0.00	ft
Beaching Check: $[Q/(gD^5)^{0.5} \leq (1.0+25*D,50/D)]$		O.K.	
**Beaching Controlled**			
Distance from Conduit Exit to C/L Pool:	Xm =	1.30	ft
Pool depth at C/L Below Conduit Invert:	Zp+0.8Zm =	1.90	ft
Pool Bottom Elev:	EI,PB =	487.10	ft
Pool Bottom Length:	2Lr2 =	1.49	ft
Pool Bottom Width:	2Wr2 =	1.45	ft
Upstream Pool Length at Tailwater Elev.:	Lru =	6.43	ft
Downstream Pool Length at Tailwater Elev.:	Lrd =	6.43	ft
Pool Width at Tailwater Elev.:	2Wr =	9.04	ft
Check Side Slope Ratio: (Wr>=We)		O.K.	
**Side Slope Ratio Zw O.K.**			
Check Min. End Slope Ratio: (Lru & Lrd >= Le)		O.K.	
**End Slope Ratios O.K.**			
Check Upstream Length: (Lru >= Xm)		O.K.	
**End Slope Ratio Zlu O.K.**			
Pool Bottom Elev. at Bottom of Riprap:	EI, BR =	486.48	ft
Pool Bottom Elev. at Bottom of Bedding:	EI, BB =	485.98	ft

**OUTPUT---VOLUMES BELOW WATER SURFACE ELEVATION:**

Volume of Excavation (measured from bottom surface of bedding):	V,pbs =	11.7	cu yd
Volume of Rock Riprap:	V,rs =	3.9	cu yd
Volume of Bedding:	V,bs =	4.7	cu yd

RIPRAP LINED PLUNGE POOL FOR CANTILEVER OUTLET  
 Reference Design Note No. 6 (Second Edition), Jan. 23, 1986

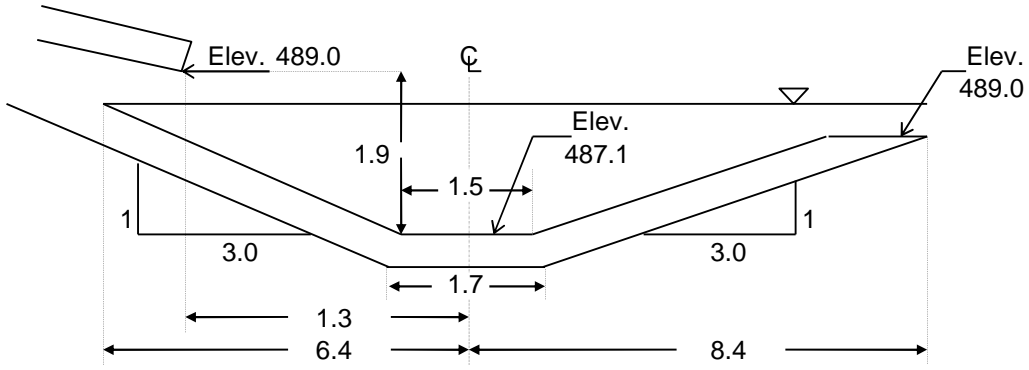

SECTION A-A

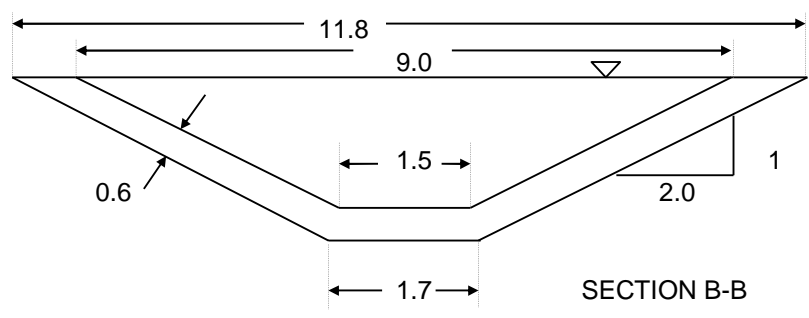

SECTION B-B

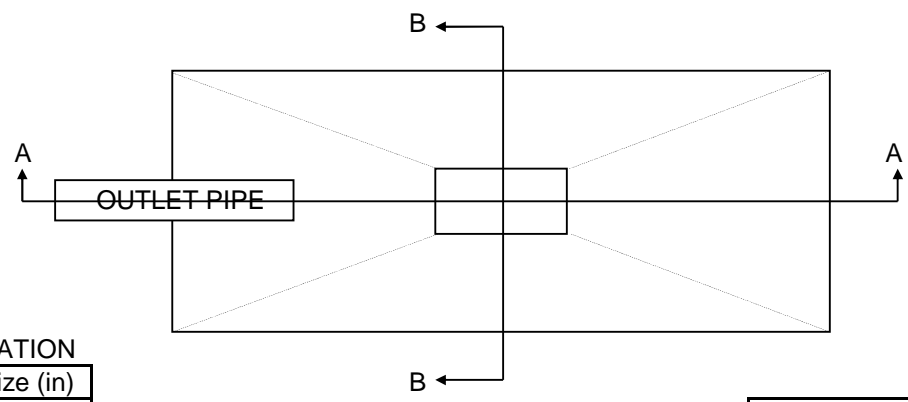

ROCK GRADATION

% Passing	Size (in)
100	6
60-85	4.5
25-50	3
5-20	1.5
0-5	0.6

Luck Stone P-SB-3 Plunge Pool  
 LANDOWNER

DESIGNER: JCC  
 SHEET 5 OF 9

RIPRAP LINED PLUNGE POOL FOR CANTILEVER OUTLET (Version 8.99)  
 (Reference Design Note No. 6 (Second Edition), Jan. 23, 1986)

JOB:	Luck Stone NE-SB-1 Plunge Pool	Date:	3/18/2021
DESIGNER:	JCC	Date:	3/18/2021
CHECKER:	AEW	Date:	3/18/2021

INPUT DATA:

Conduit Diameter	D =	2.00	ft
Conduit Discharge:	Q =	6.55	cfs
Conduit Slope at Outlet:	S =	0.01	ft/ft
Conduit Outlet Invert Elevation:	EI, CO =	426.00	ft
Tailwater Elevation:	EI, TW =	426.00	ft
Outlet Channel Invert Elevation:	EI, CH =	426.00	ft

Water Density:	RHO =	1.00	
Bed/Riprap Particle Density: (Default 2.64)	RHOS =	2.64	
D, 50 Riprap Size:	RS =	0.25	ft
Riprap Thickness: (2.5*D, 50 recommended)	RT =	0.63	ft
Bedding Thickness: (6 inch min. rec.) ( <u>Enter 0 for geotextile</u> )	BT =	0.50	ft
Side Slope Ratio:	Zw =	2.00	ft/ft
Upstream End Slope Ratio:	Zlu =	3.00	ft/ft
Downstream End Slope Ratio:	Zld =	3.00	ft/ft
Combined End Slope Ratio:	Z1 =	3.00	ft/ft

OUTPUT---POOL LOCATION AND DIMENSIONS:

Vert. Dist. from Tailwater to Conduit Invert:	Zp =	0.00	ft
Submergence Check: (If Zp < 0 , Use Zp = 0)	Use Zp =	0.00	ft
Beaching Check: $[Q/(gD^{.5})^{0.5} \leq (1.0+25 \cdot D, 50/D)]$		O.K.	
**Beaching Controlled**			
Distance from Conduit Exit to C/L Pool:	Xm =	1.25	ft
Pool depth at C/L Below Conduit Invert:	Zp+0.8Zm =	1.87	ft
Pool Bottom Elev:	EI,PB =	424.13	ft
Pool Bottom Length:	2Lr2 =	1.46	ft
Pool Bottom Width:	2Wr2 =	1.43	ft
Upstream Pool Length at Tailwater Elev.:	Lru =	6.33	ft
Downstream Pool Length at Tailwater Elev.:	Lrd =	6.33	ft
Pool Width at Tailwater Elev.:	2Wr =	8.90	ft
Check Side Slope Ratio: (Wr>=We)		O.K.	
**Side Slope Ratio Zw O.K.**			
Check Min. End Slope Ratio: (Lru & Lrd >= Le)		O.K.	
**End Slope Ratios O.K.**			
Check Upstream Length: (Lru >= Xm)		O.K.	
**End Slope Ratio Zlu O.K.**			
Pool Bottom Elev. at Bottom of Riprap:	EI, BR =	423.51	ft
Pool Bottom Elev. at Bottom of Bedding:	EI, BB =	423.01	ft

**OUTPUT---VOLUMES BELOW WATER SURFACE ELEVATION:**

Volume of Excavation (measured from bottom surface of bedding):	V,pbs =	11.4	cu yd
Volume of Rock Riprap:	V,rs =	3.8	cu yd
Volume of Bedding:	V,bs =	4.6	cu yd

RIPRAP LINED PLUNGE POOL FOR CANTILEVER OUTLET  
 Reference Design Note No. 6 (Second Edition), Jan. 23, 1986

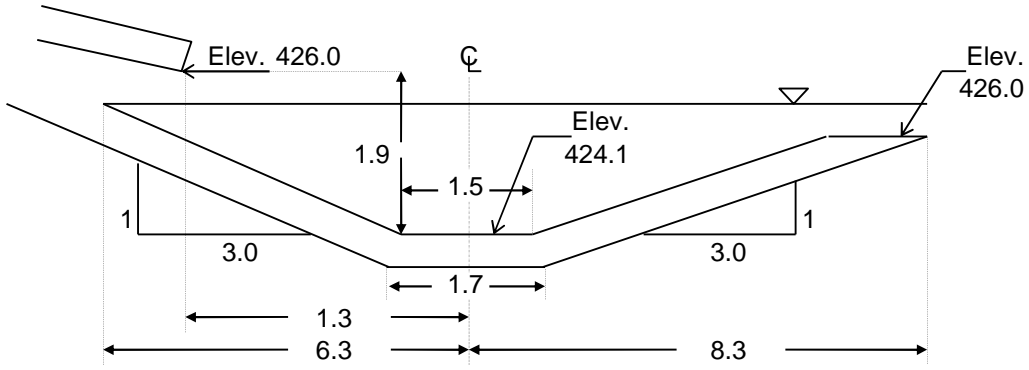

SECTION A-A

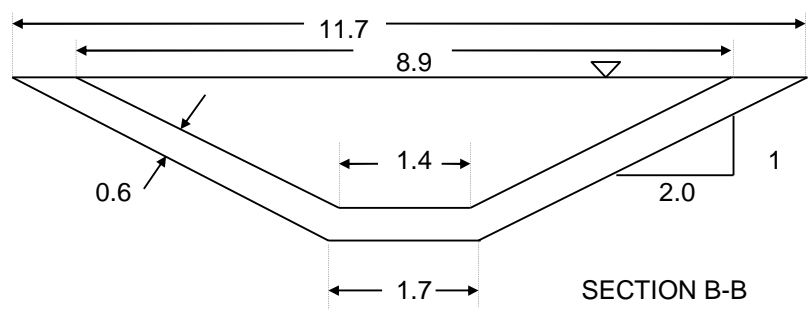

SECTION B-B

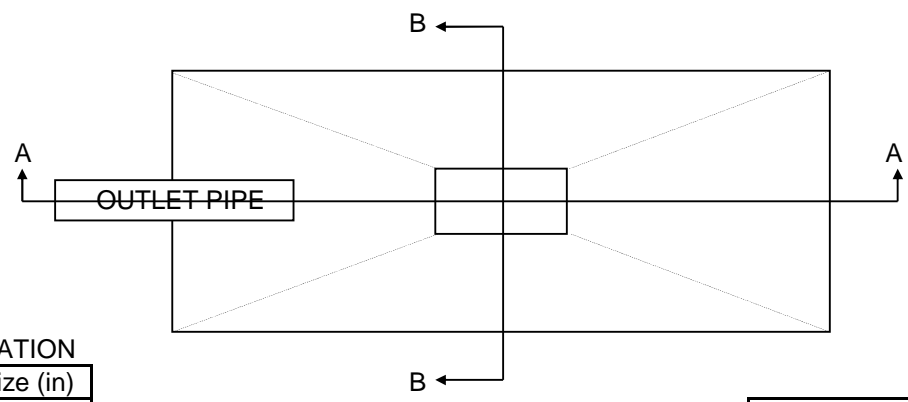

ROCK GRADATION

% Passing	Size (in)
100	6
60-85	4.5
25-50	3
5-20	1.5
0-5	0.6

Luck Stone NE-SB-1 Plunge Pool  
 LANDOWNER  
 DESIGNER: JCC  
 SHEET 6 OF 9

RIPRAP LINED PLUNGE POOL FOR CANTILEVER OUTLET (Version 8.99)  
 (Reference Design Note No. 6 (Second Edition), Jan. 23, 1986)

JOB:	Luck Stone NE-SB-2 Plunge Pool	Date:	3/9/2021
DESIGNER:	JCC	Date:	3/9/2021
CHECKER:	AEW	Date:	3/9/2021

INPUT DATA:

Conduit Diameter	D =	2.00	ft
Conduit Discharge:	Q =	3.52	cfs
Conduit Slope at Outlet:	S =	0.01	ft/ft
Conduit Outlet Invert Elevation:	EI, CO =	411.00	ft
Tailwater Elevation:	EI, TW =	411.00	ft
Outlet Channel Invert Elevation:	EI, CH =	411.00	ft

Water Density:	RHO =	1.00	
Bed/Riprap Particle Density: (Default 2.64)	RHOS =	2.64	
D, 50 Riprap Size:	RS =	0.25	ft
Riprap Thickness: (2.5*D, 50 recommended)	RT =	0.63	ft
Bedding Thickness: (6 inch min. rec.) ( <u>Enter 0 for geotextile</u> )	BT =	0.50	ft
Side Slope Ratio:	Zw =	2.00	ft/ft
Upstream End Slope Ratio:	Zlu =	3.00	ft/ft
Downstream End Slope Ratio:	Zld =	3.00	ft/ft
Combined End Slope Ratio:	Z1 =	3.00	ft/ft

OUTPUT---POOL LOCATION AND DIMENSIONS:

Vert. Dist. from Tailwater to Conduit Invert:	Zp =	0.00	ft
Submergence Check: (If Zp < 0 , Use Zp = 0)	Use Zp =	0.00	ft
Beaching Check: $[Q/(gD^{.5})^{0.5} \leq (1.0+25 \cdot D, 50/D)]$		O.K.	
**Beaching Controlled**			
Distance from Conduit Exit to C/L Pool:	Xm =	0.62	ft
Pool depth at C/L Below Conduit Invert:	Zp+0.8Zm =	1.55	ft
Pool Bottom Elev:	EI, PB =	409.45	ft
Pool Bottom Length:	2Lr2 =	1.19	ft
Pool Bottom Width:	2Wr2 =	1.17	ft
Upstream Pool Length at Tailwater Elev.:	Lru =	5.23	ft
Downstream Pool Length at Tailwater Elev.:	Lrd =	5.23	ft
Pool Width at Tailwater Elev.:	2Wr =	7.36	ft
Check Side Slope Ratio: (Wr >= We)		O.K.	
**Side Slope Ratio Zw O.K.**			
Check Min. End Slope Ratio: (Lru & Lrd >= Le)		O.K.	
**End Slope Ratios O.K.**			
Check Upstream Length: (Lru >= Xm)		O.K.	
**End Slope Ratio Zlu O.K.**			
Pool Bottom Elev. at Bottom of Riprap:	EI, BR =	408.83	ft
Pool Bottom Elev. at Bottom of Bedding:	EI, BB =	408.33	ft

**OUTPUT---VOLUMES BELOW WATER SURFACE ELEVATION:**

Volume of Excavation (measured from bottom surface of bedding):	V,pbs =	8.0	cu yd
Volume of Rock Riprap:	V,rs =	2.7	cu yd
Volume of Bedding:	V,bs =	3.6	cu yd

RIPRAP LINED PLUNGE POOL FOR CANTILEVER OUTLET  
 Reference Design Note No. 6 (Second Edition), Jan. 23, 1986

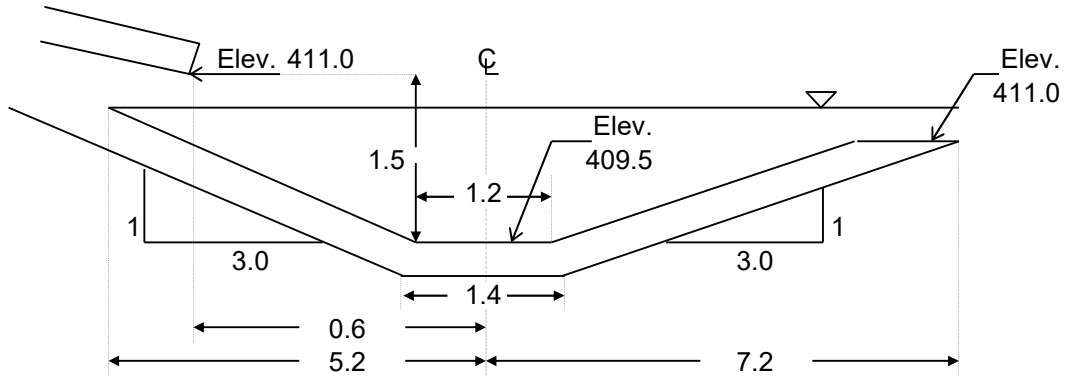

SECTION A-A

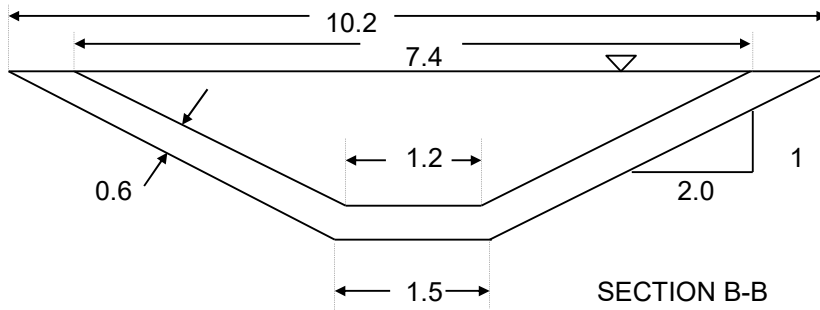

SECTION B-B

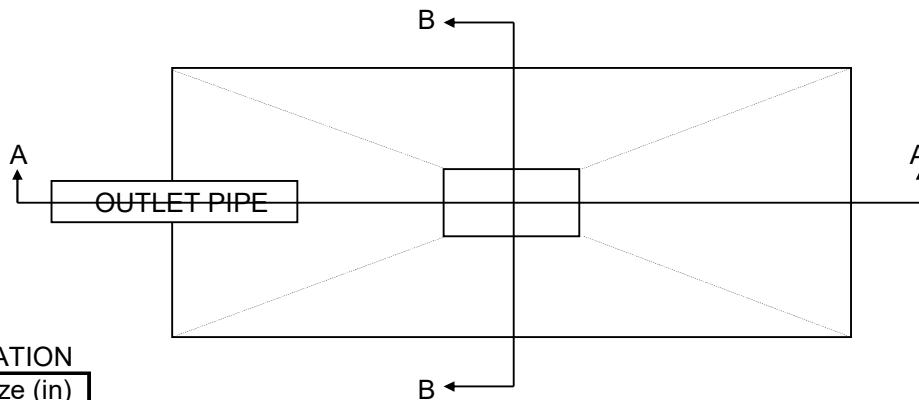

ROCK GRADATION

% Passing	Size (in)
100	6
60-85	4.5
25-50	3
5-20	1.5
0-5	0.6

Luck Stone NE-SB-2 Plunge Pool  
 LANDOWNER

DESIGNER: JCC  
 SHEET 7 OF 9



RIPRAP LINED PLUNGE POOL FOR CANTILEVER OUTLET (Version 8.99)  
 (Reference Design Note No. 6 (Second Edition), Jan. 23, 1986)

JOB:	Luck Stone NE-SB-3 Plunge Pool	Date:	3/9/2021
DESIGNER:	JCC	Date:	3/9/2021
CHECKER:	AEW	Date:	3/9/2021

INPUT DATA:

Conduit Diameter	D =	2.00	ft
Conduit Discharge:	Q =	3.87	cfs
Conduit Slope at Outlet:	S =	0.01	ft/ft
Conduit Outlet Invert Elevation:	EI, CO =	411.00	ft
Tailwater Elevation:	EI, TW =	411.00	ft
Outlet Channel Invert Elevation:	EI, CH =	411.00	ft

Water Density:	RHO =	1.00	
Bed/Riprap Particle Density: (Default 2.64)	RHOS =	2.64	
D, 50 Riprap Size:	RS =	0.25	ft
Riprap Thickness: (2.5*D, 50 recommended)	RT =	0.63	ft
Bedding Thickness: (6 inch min. rec.) ( <u>Enter 0 for geotextile</u> )	BT =	0.50	ft
Side Slope Ratio:	Zw =	2.00	ft/ft
Upstream End Slope Ratio:	Zlu =	3.00	ft/ft
Downstream End Slope Ratio:	Zld =	3.00	ft/ft
Combined End Slope Ratio:	Z1 =	3.00	ft/ft

OUTPUT---POOL LOCATION AND DIMENSIONS:

Vert. Dist. from Tailwater to Conduit Invert:	Zp =	0.00	ft
Submergence Check: (If Zp < 0 , Use Zp = 0)	Use Zp =	0.00	ft
Beaching Check: $[Q/(gD^{.5})^{0.5} \leq (1.0+25*D,50/D)]$		O.K.	
**Beaching Controlled**			
Distance from Conduit Exit to C/L Pool:	Xm =	0.69	ft
Pool depth at C/L Below Conduit Invert:	Zp+0.8Zm =	1.57	ft
Pool Bottom Elev:	EI,PB =	409.43	ft
Pool Bottom Length:	2Lr2 =	1.21	ft
Pool Bottom Width:	2Wr2 =	1.20	ft
Upstream Pool Length at Tailwater Elev.:	Lru =	5.33	ft
Downstream Pool Length at Tailwater Elev.:	Lrd =	5.33	ft
Pool Width at Tailwater Elev.:	2Wr =	7.49	ft
Check Side Slope Ratio: (Wr>=We)		O.K.	
**Side Slope Ratio Zw O.K.**			
Check Min. End Slope Ratio: (Lru & Lrd >= Le)		O.K.	
**End Slope Ratios O.K.**			
Check Upstream Length: (Lru >= Xm)		O.K.	
**End Slope Ratio Zlu O.K.**			
Pool Bottom Elev. at Bottom of Riprap:	EI, BR =	408.80	ft
Pool Bottom Elev. at Bottom of Bedding:	EI, BB =	408.30	ft

**OUTPUT---VOLUMES BELOW WATER SURFACE ELEVATION:**

Volume of Excavation (measured from bottom surface of bedding):	V,pbs =	8.3	cu yd
Volume of Rock Riprap:	V,rs =	2.8	cu yd
Volume of Bedding:	V,bs =	3.6	cu yd

RIPRAP LINED PLUNGE POOL FOR CANTILEVER OUTLET  
 Reference Design Note No. 6 (Second Edition), Jan. 23, 1986

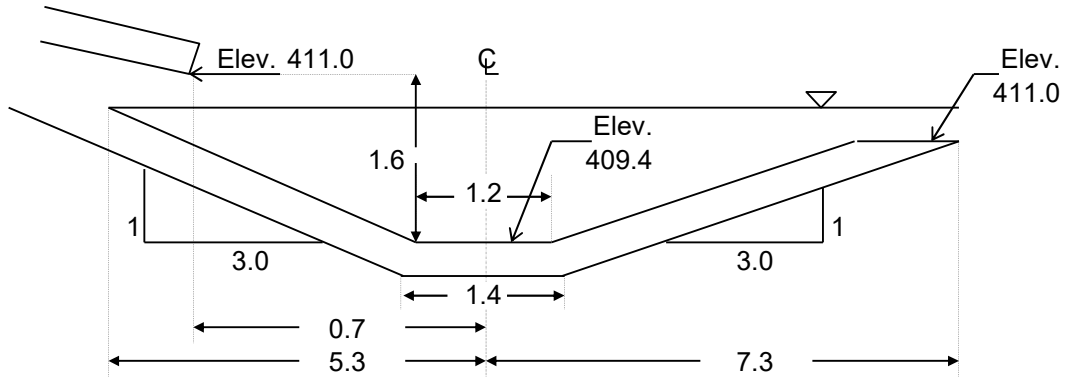

SECTION A-A

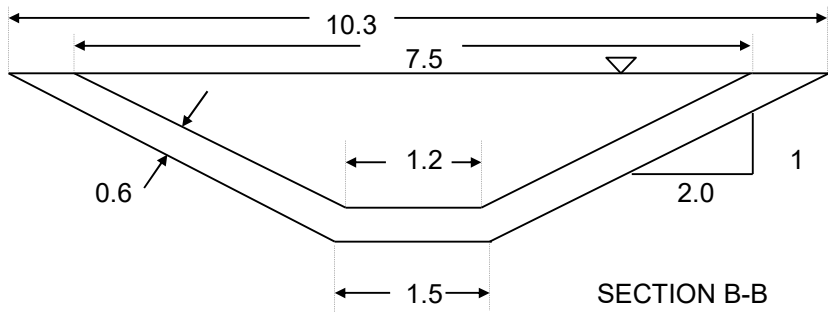

SECTION B-B

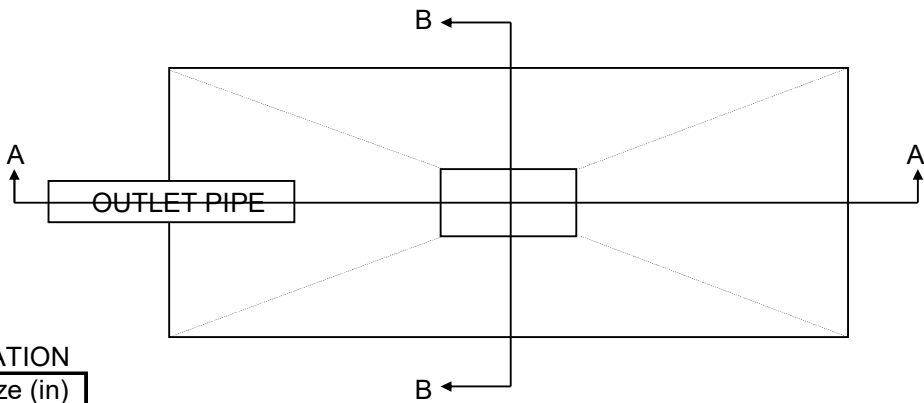

ROCK GRADATION

% Passing	Size (in)
100	6
60-85	4.5
25-50	3
5-20	1.5
0-5	0.6

Luck Stone NE-SB-3 Plunge Pool  
 LANDOWNER

DESIGNER: JCC  
 SHEET 8 OF 9

RIPRAP LINED PLUNGE POOL FOR CANTILEVER OUTLET (Version 8.99)  
 (Reference Design Note No. 6 (Second Edition), Jan. 23, 1986)

JOB:	Luck Stone NE-SB-4 Plunge Pool	Date:	3/9/2021
DESIGNER:	JCC	Date:	3/9/2021
CHECKER:	AEW		

INPUT DATA:

Conduit Diameter	D =	2.00	ft
Conduit Discharge:	Q =	5.51	cfs
Conduit Slope at Outlet:	S =	0.01	ft/ft
Conduit Outlet Invert Elevation:	EI, CO =	478.00	ft
Tailwater Elevation:	EI, TW =	478.00	ft
Outlet Channel Invert Elevation:	EI, CH =	478.00	ft

Water Density:	RHO =	1.00	
Bed/Riprap Particle Density: (Default 2.64)	RHOS =	2.64	
D, 50 Riprap Size:	RS =	0.25	ft
Riprap Thickness: (2.5*D, 50 recommended)	RT =	0.63	ft
Bedding Thickness: (6 inch min. rec.) ( <u>Enter 0 for geotextile</u> )	BT =	0.50	ft
Side Slope Ratio:	Zw =	2.00	ft/ft
Upstream End Slope Ratio:	Zlu =	3.00	ft/ft
Downstream End Slope Ratio:	Zld =	3.00	ft/ft
Combined End Slope Ratio:	Z1 =	3.00	ft/ft

OUTPUT---POOL LOCATION AND DIMENSIONS:

Vert. Dist. from Tailwater to Conduit Invert:	Zp =	0.00	ft
Submergence Check: (If Zp < 0 , Use Zp = 0)	Use Zp =	0.00	ft
Beaching Check: $[Q/(gD^{.5})^{0.5} \leq (1.0+25 \cdot D, 50/D)]$		O.K.	
**Beaching Controlled**			
Distance from Conduit Exit to C/L Pool:	Xm =	1.02	ft
Pool depth at C/L Below Conduit Invert:	Zp+0.8Zm =	1.74	ft
Pool Bottom Elev:	EI, PB =	476.26	ft
Pool Bottom Length:	2Lr2 =	1.35	ft
Pool Bottom Width:	2Wr2 =	1.33	ft
Upstream Pool Length at Tailwater Elev.:	Lru =	5.89	ft
Downstream Pool Length at Tailwater Elev.:	Lrd =	5.89	ft
Pool Width at Tailwater Elev.:	2Wr =	8.28	ft
Check Side Slope Ratio: (Wr >= We)		O.K.	
**Side Slope Ratio Zw O.K.**			
Check Min. End Slope Ratio: (Lru & Lrd >= Le)		O.K.	
**End Slope Ratios O.K.**			
Check Upstream Length: (Lru >= Xm)		O.K.	
**End Slope Ratio Zlu O.K.**			
Pool Bottom Elev. at Bottom of Riprap:	EI, BR =	475.64	ft
Pool Bottom Elev. at Bottom of Bedding:	EI, BB =	475.14	ft

**OUTPUT---VOLUMES BELOW WATER SURFACE ELEVATION:**

Volume of Excavation (measured from bottom surface of bedding):	V,pbs =	9.9	cu yd
Volume of Rock Riprap:	V,rs =	3.4	cu yd
Volume of Bedding:	V,bs =	4.2	cu yd

RIPRAP LINED PLUNGE POOL FOR CANTILEVER OUTLET  
 Reference Design Note No. 6 (Second Edition), Jan. 23, 1986

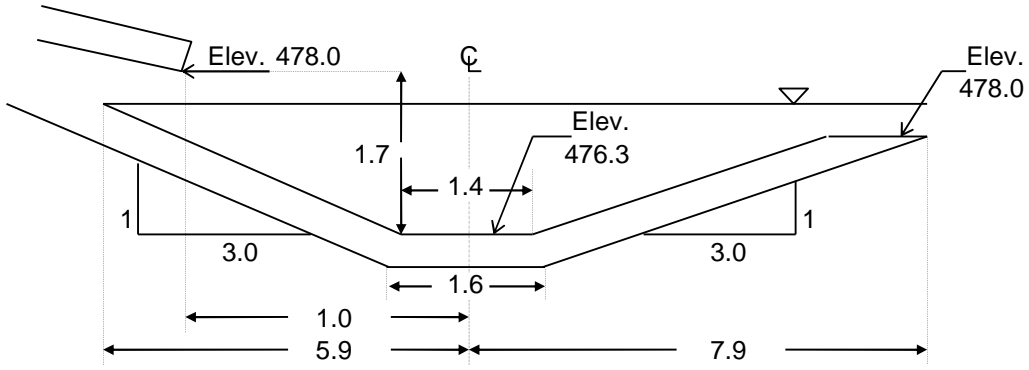

SECTION A-A

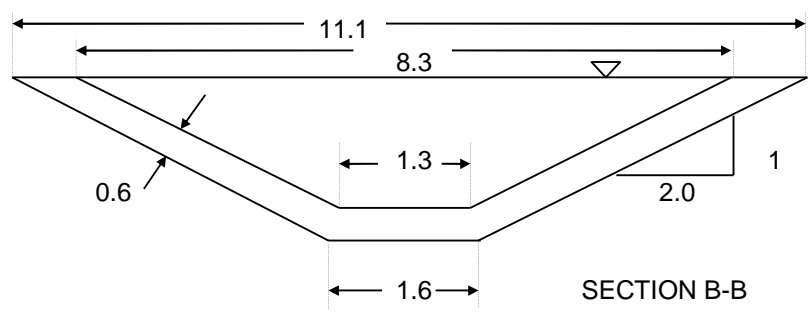

SECTION B-B

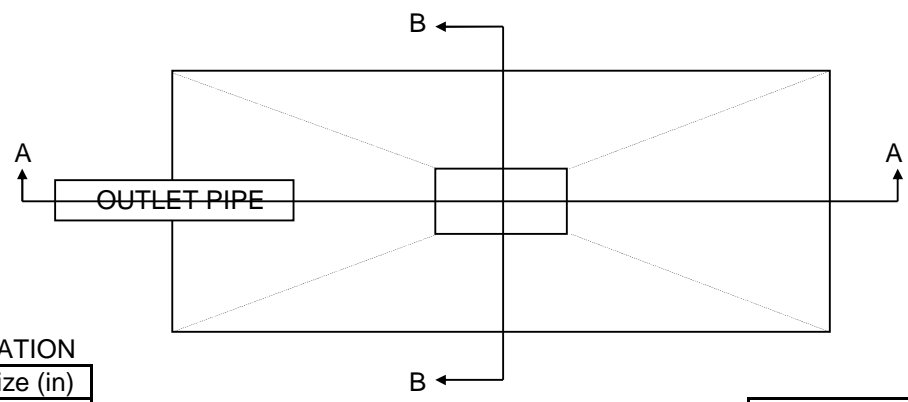

ROCK GRADATION

% Passing	Size (in)
100	6
60-85	4.5
25-50	3
5-20	1.5
0-5	0.6

Luck Stone NE-SB-4 Plunge Pool  
 LANDOWNER  
 DESIGNER: JCC  
 SHEET   9   OF   9